

# MAINTENANCE

	Page
MAINTENANCE SCHEDULE .....	MA-2
MAINTENANCE OPERATIONS .....	MA-6
GENERAL MAINTENANCE .....	MA-14



**GENERAL NOTES:**

- The maintenance schedule for the vehicle consists of separate A and B schedules which are applicable depending on how the vehicle is used. Confirm the vehicle’s usage conditions, select the appropriate schedule and service the vehicle accordingly.
- Every service item in the periodic maintenance list be performed.
- Failure to do even one item can cause the engine to run poorly and increase exhaust emissions.



**SCHEDULE A (Cont'd)**

System	Service interval (Odometer reading or months, whichever comes first)	Maintenance services beyond 60,000 miles (9,6000 km) should be performed at the same intervals shown in each maintenance schedule.																	See Page (item No.)		
		Maintenance items																			
		Miles × 1,000	3.75	7.5	11.25	15	18.75	22.5	26.25	30	33.75	37.5	41.25	45	48.75	52.5	56.25	60		Months	
BRAKES	Miles × 1,000	6	12	18	24	30	36	42	48	54	60	66	72	78	84	90	96				
	km × 1,000																				
	Brake linings and drums (4)		I	I	I	I	I	I	I	I	I	I	I	I	I	I	I	I	I: Every 12 months	MA-9 (item 15)	
CHASSIS	Brake pads and discs		I	I	I	I	I	I	I	I	I	I	I	I	I	I	I	I	I	I: Every 12 months	MA-9 (item 14)
	Brake line pipes and hoses																			I: Every 24 months	MA-9 (item 13)
	Steering linkage		I	I	I	I	I	I	I	I	I	I	I	I	I	I	I	I	I	I: Every 12 months	MA-10 (item 16)
	SRS airbag	I: First period, 10 years I: After that, every 2 years																	MA-10 (item 17)		
	Ball joints and dust covers		I	I	I	I	I	I	I	I	I	I	I	I	I	I	I	I	I	I: Every 12 months	MA-11 (item 19)
	Automatic transmission, manual transmission and differential oil				R									R						R I: Every 24 months	MA-11 (item 21)
	Steering gear housing oil (5)																			I: Every 24 months	MA-10 (item 18)
	Bolts and nuts on chassis and body (6)																			I: Every 12 months	MA-12 (item 22)

★ Mark indicates maintenance which is part of the warranty conditions for the engine control system. The warranty period is in accordance with the owner's guide or the warranty booklet. (★ : California specification vehicles.)

**NOTE:**

- (1) Applicable to vehicles operated under conditions of extensive idling and / or low speed driving for long distances such as police, taxi or door-to-door delivery use.
- (2) Applicable when operating mainly on dusty roads.
- (3) Includes inspection of vapor vent system.
- (4) Also applicable to lining drum for parking brake.
- (5) Check for oil leaks from steering gear box.
- (6) Applicable only when operating mainly on rough, muddy roads. The applicable parts are listed below. For other usage conditions, refer to SCHEDULE B.
  - Front and rear suspension member to cross body.
  - Bolts for sheet installation.



**SCHEDULE B (Cont'd)**

System	Service interval (Use odometer reading or months, whichever comes first)	Maintenance services beyond 60,000 miles (96,000 km) should continue to be performed at the same intervals shown for each maintenance schedule.												See Page (item No.)				
		Miles × 1,000						Months										
		7.5	15	22.5	30	37.5	45	52.5	60	7.5	15	22.5	30		37.5	45	52.5	60
	Maintenance items km × 1,000	12	24	36	48	60	72	84	96									
CHASSIS	Steering linkage		I		I		I		I		I		I		I		I	MA-10 (item 16)
	SRS airbag	I: First period, 10 years I: After that, every 2 years																MA-10 (item 17)
	Ball joints and dust covers		I		I		I		I		I		I		I		I	MA-11 (item 19)
	Automatic transmission, manual transmission and differential (ex. LSD) oil		I		I		I		I		I		I		I		I	MA-11 (item 20)
	Limited slip differential (LSD) oil (3)		I		R		I		R		I		R		I		R	MA-11 (item 20) MA-11 (item 21)
	Steering gear housing oil (4)		I		I		I		I		I		I		I		I	MA-10 (item 18)
	Bolts and nuts on chassis and body (5)		I		I		I		I		I		I		I		I	MA-12 (item 22)

★ Mark indicates maintenance which is part of the warranty conditions for the engine control system. The warranty period is in accordance with the owner's guide or the warranty booklet. (★ : California specification vehicles.)

NOTE:

- (1) Includes inspection of vapor vent system.
- (2) Also applicable to lining drum for parking brake.
- (3) Check for oil leaks.
- (4) Check for oil leaks from steering gear box.
- (5) The applicable parts are listed below.
  - Front and rear suspension member to cross body.
  - Bolts for sheet installation.

# MAINTENANCE OPERATIONS

## ENGINE

### Cold Engine Operations

#### 1. REPLACE TIMING BELT

- (a) Remove the timing belt.  
(See pages EM-22 to 25)
- (b) Install the timing belt.  
(See pages EM-28 to 31)

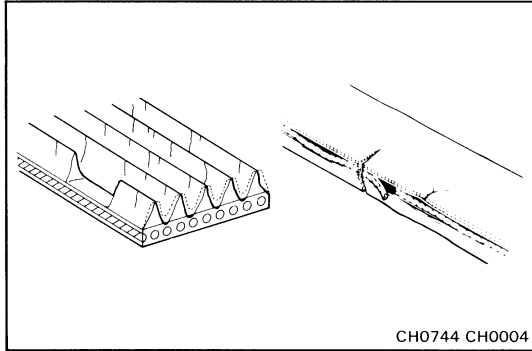

#### 2. INSPECT DRIVE BELTS

- (a) Visually check the belt for excessive wear, frayed cords etc.

If necessary, replace the drive belt.

**HINT:** Cracks on the rib side of a belt are considered acceptable. If the belt has chunks missing from the ribs, it should be replaced.

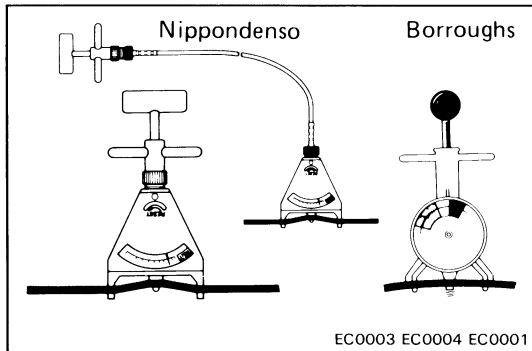

- (b) Using a belt tension gauge, check the drive belt tension.

Belt tension gauge:

Nippondenso BTG-20 (95506-00020)

Borroughs No. BT-33-73F

**Drive belt tension:**

Alternator	Used belt	115 ± 20 lb
	New belt	175 ± 5 lb
PS pump	Used belt	100 ± 20 lb
	New belt	160 ± 20 lb
A/C	Used belt	105 ± 10 lb
	New belt	160 ± 20 lb

If necessary, adjust the drive belt tension.

**HINT:**

- "New belt" refers to a belt which has been used less than 5 minutes on a running engine.
- "Used belt" refers to a belt which has been used on a running engine for 5 minutes or more.
- After replacing the drive belt, check that it fits properly in the ribbed grooves, especially in the places difficult to see.
- After installing a new belt, run the engine for approx. 5 minutes and then recheck the tension.

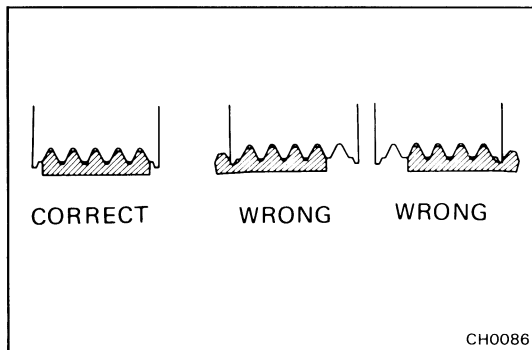

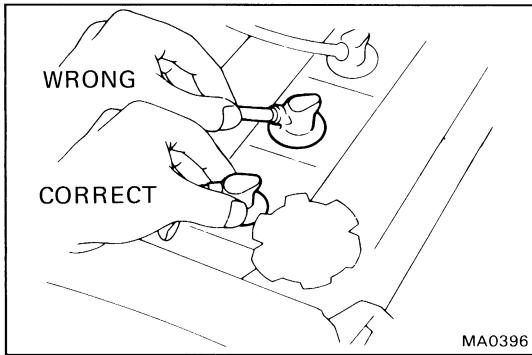

**3. REPLACE SPARK PLUGS**

- (a) Disconnect the high-tension cords at the boot. Do not pull on the cords.
- (b) Using plug wrench (16 mm), remove the spark plugs.
- (c) Check the gap on the new plugs.

**Correct electrode gap**

7M-GE	1.1 mm (0.043 in.)
7M-GTE	0.8 mm (0.031 in.)

**Recommended spark plugs:**

7M-GE	ND	PQ16R
	NGK	BCPR5EP11
7M-GTE	ND	PQ20R-P8
	NGK	BCPR6EP-N8

**HINT:** If adjusting the gap of a new plug, bend only the base of the ground electrode. Do not touch the tip. Never attempt to adjust the gap on a used plug.

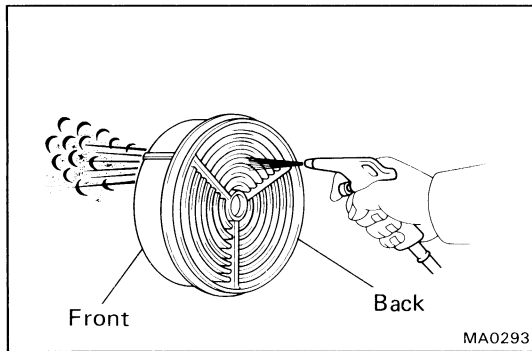
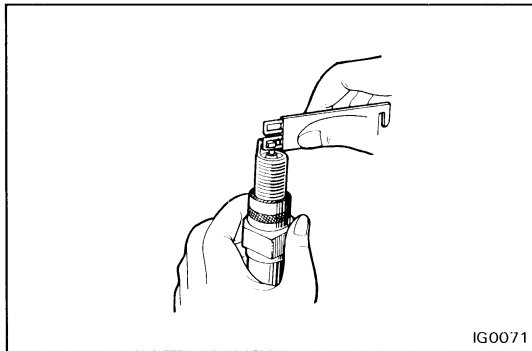

**4. INSPECT AIR FILTER**

- (a) Visually check that the air cleaner element is not excessively dirty, damaged or oily.

If necessary, replace the air cleaner element.

- (b) Clean the element with compressed air.

First blow from the back side thoroughly, then blow off the front side of the element.

**5. REPLACE AIR FILTER**

Replace the air cleaner element with a new one.

**6. REPLACE ENGINE OIL AND OIL FILTER**  
(See page LU-5)

**Oil grade:** API grade SG, multigrade, fuel-efficient and recommended viscosity oil.

**Engine oil capacity:**

**Drain and refill**

w/o	Oil filter change	4.1 liters (4.3 US qts, 3.6 Imp. qts)
w/	Oil filter change	4.4 liters (4.7 US qts, 3.9 Imp. qts)

**7. REPLACE ENGINE COOLANT**  
(See page CO-5)

**Coolant capacity (w/ Heater or air conditioner):**

7M-GE	M/T	8.1 liters (8.6 US qts, 7.1 Imp. qts)
	A/T	8.0 liters (8.5 US qts, 7.0 Imp. qts)
7M-GTE	M/T	8.2 liters (8.7 US qts, 7.2 Imp. qts)
	A/T	8.1 liters (8.5 US qts, 7.1 Imp. qts)

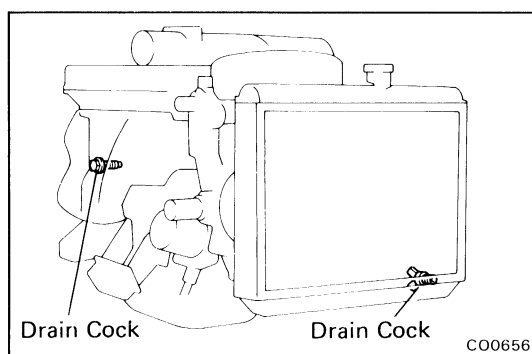

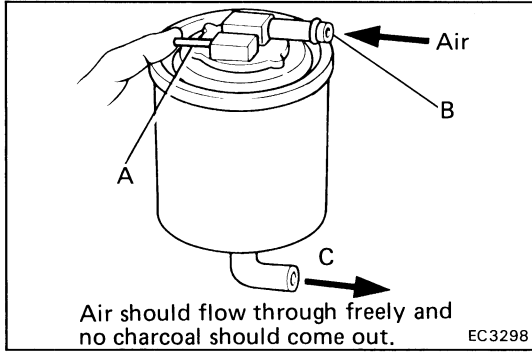

## 8. INSPECT CHARCOAL CANISTER

- (a) Disconnect the hoses from the charcoal canister. Label the hoses for correct reinstallation.
- (b) Plug pipe A with your finger and blow compressed air (3 kg/cm<sup>2</sup>, 43 psi or 294 kPa) through pipe B (fuel tank side).
  - Check that air comes out of the bottom pipe C without resistance.
  - Check that no activated charcoal comes out.

If necessary, replace the charcoal canister.

HINT: Do not attempt to wash the charcoal.

- (c) Connect the hoses to the charcoal canister.

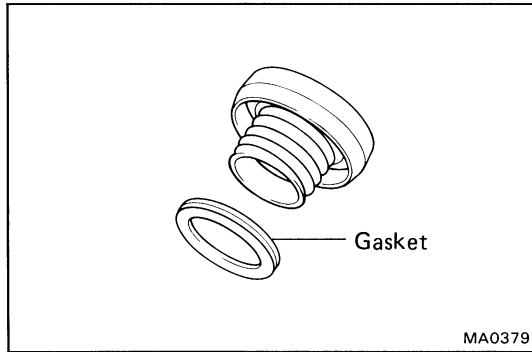

## 9. REPLACE GASKET IN FUEL TANK CAP

- (a) Remove the old gasket (O-ring) from the tank cap. Do not damage the cap.
- (b) Install the new gasket by hand.
- (c) Inspect the cap for damage or cracks.
- (d) Install the cap and check the torque limiter.

## 10. INSPECT FUEL LINES AND CONNECTIONS

Visually inspect the fuel lines for cracks, leakage, loose connections, deformation or tank band looseness.

## 11. INSPECT EXHAUST PIPES AND MOUNTINGS

Visually inspect the pipes, hangers, and connections for severe corrosion, leaks or damage.

## 12. ADJUST VALVE CLEARANCE

HINT: Check and adjust the valve clearance while the engine is cold.

- (a) Remove the cylinder head covers.
- (b) Measure and adjust valve clearance.  
(See page EM-7)

**Valve clearance (cold):**

**Intake** 0.15 – 0.25 mm (0.006 – 0.010 in.)  
**Exhaust** 0.20 – 0.30 mm (0.008 – 0.012 in.)

- (c) Reinstall the cylinder head covers.



## BRAKES

### 13. INSPECT BRAKE LINE PIPES AND HOSES

**HINT:** Inspect in a well lighted area. Inspect the entire circumference and length of the brake hoses using a mirror as required. Turn the front wheels fully right or left before inspecting the front brake.

- (a) Check all brake lines and hoses for:
  - Damage
  - Wear
  - Deformation
  - Cracks
  - Corrosion
  - Leaks
  - Bends
  - Twists
- (b) Check all clamps for tightness and connections for leakage.
- (c) Check that the hoses and lines are clear of sharp edges, moving parts and the exhaust system.
- (d) Check that the lines installed in grommets pass through the center of the grommets.

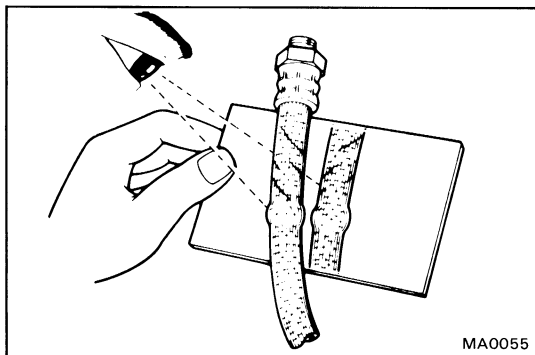

### 14. INSPECT FRONT AND REAR BRAKE PADS AND DISCS (See pages BR-28, 36)

- (a) Check the thickness of the disc brake pads and check for irregular wear.

**Minimum pad thickness: 1.0 mm (0.039 in.)**

**HINT:** If a squealing or scraping noise comes from the brake during driving, check the pad wear indicator. If there are traces of the indicator contacting the disc rotor, the disc pad should be replaced.

- (b) Check the disc for wear or runout.

**Minimum disc thickness:**

**Front 21.0 mm (0.827 in.)**

**Rear 17.0 mm (0.669 in.)**

**Maximum disc runout: 0.13 mm (0.0051 in.)**

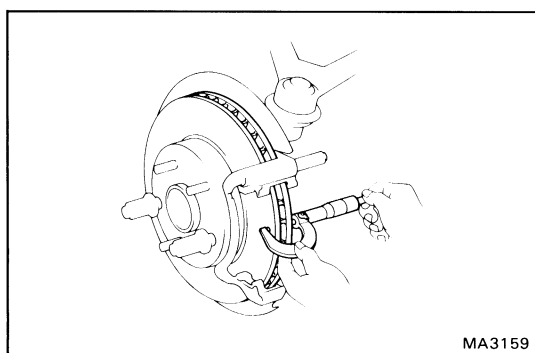
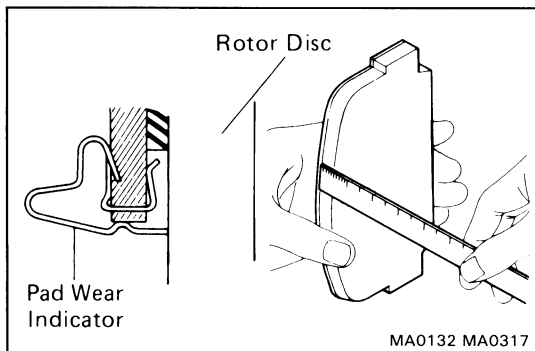

### 15. INSPECT PARKING BRAKE LININGS AND DRUMS (See page BR-41)

- (a) Check the lining-to-drum contact condition and lining wear.

**Minimum lining thickness: 1.0 mm (0.039 in.)**

- (b) Check the brake drum for scoring or wear.

**Maximum drum inside diameter: 191 mm (7.52 in.)**

- (c) Clean the brake parts with a damp cloth.

**HINT:** Do not use compressed air to clean the brake parts.

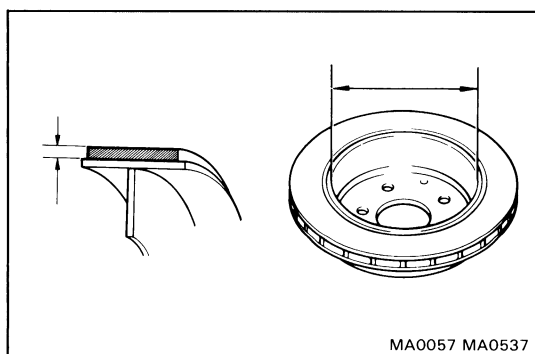

- (d) Settle the parking brake shoes and drum. When performing the road test in item 23, do the following:
- Drive the vehicle at approx. 30 mph (50 km/h) on a safe, level and dry road.
  - With the parking brake release button pushed in, pull on the lever with 9 kg (20 lb, 88 N) of force.
  - Drive the vehicle for approx. 1/4 mile (400 meters) in this condition.
  - Repeat this procedure 2 or 3 times.
  - Check parking lever travel.

If necessary, adjust the parking brake.

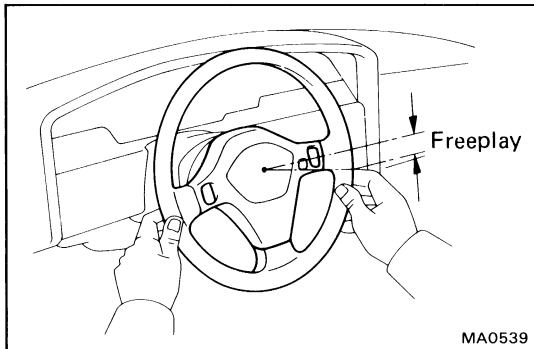

## CHASSIS

### 16. INSPECT STEERING LINKAGE

- (a) Check the steering wheel freeplay.

**Maximum steering wheel freeplay: 30 mm (1.18 in.)**

With the vehicle stopped and pointed straight ahead, rock the steering wheel gently back and forth with light finger pressure.

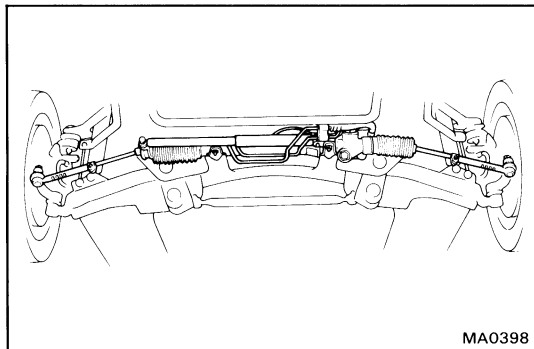

- (b) Check the steering linkage for looseness or damage.

Check that:

- Tie rod ends do not have excessive play.
- Dust seals and boots are not damaged.
- Boot clamps are not loose.

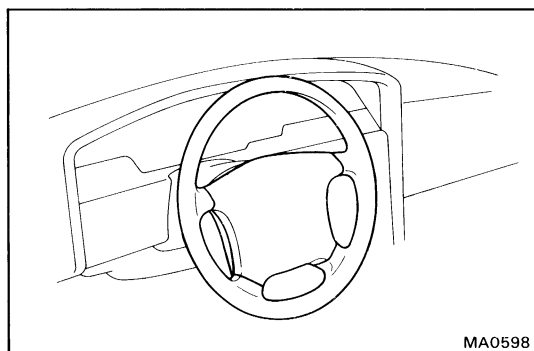

### 17. INSPECT SRS AIRBAG

Visually inspect the steering wheel pad (airbag and inflator).

- Use the diagnosis check to check if there are abnormalities.
- Check that there are no cuts, cracks or noticeable color changes on the surface of the steering wheel pad or in the center groove of the pad.
- Remove the steering wheel pad from the vehicle and check the wiring and steering wheel for damage and corrosion due to rusting, etc.

If necessary, replace the steering wheel pad.

#### CAUTION:

- For removal and replacement of the steering wheel pad, see page SR-5 and be sure to perform the operation in the correct order.
- Before disposing of the steering wheel pad, the airbag must first be deployed by using an SST. (See page AB-82)

### 18. INSPECT STEERING GEAR HOUSING OIL

Check the steering gear housing for oil leakage.

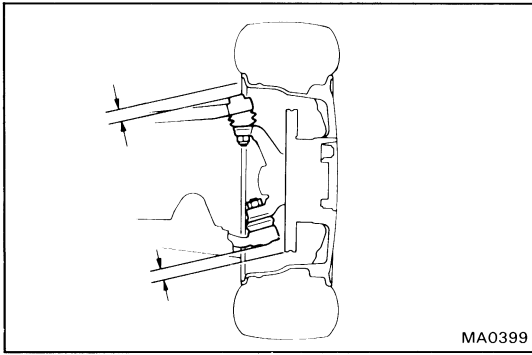

MA0399

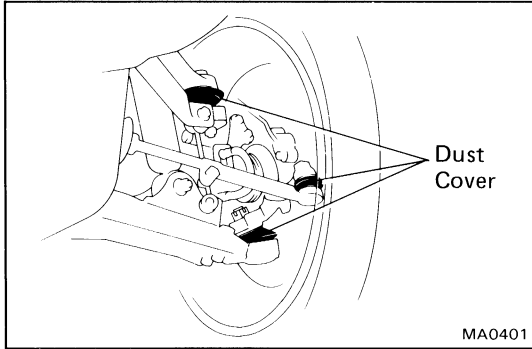

MA0401

**19. INSPECT UPPER AND LOWER BALL JOINTS AND DUST COVERS**

- (a) Inspect the ball joints for excessive looseness.
  - Jack up the front of the vehicle and place wooden blocks with a height of 180 — 200 mm (7.09 — 7.87 in.) under the front tires.
  - Lower the jack until there is about half a load on the front coil springs. Place stands under the vehicle for safety.
  - Make sure the front wheels are in a straight forward position, and block them with chocks.
  - Using a lever, pry up the end of the upper and lower arm, and check the amount of play.

**Maximum ball joint vertical play:**

**Upper 0 mm (0 in.)**

**Lower 0.3 mm (0.012 in.)**

If there is play, replace the ball joint.

- (b) Inspect the dust cover for damage.

**20. CHECK AUTOMATIC TRANSMISSION OR MANUAL TRANSMISSION AND DIFFERENTIAL OIL**

Visually check the automatic transmission or manual transmission and differential for oil leakage.

If leakage is found, check for cause and repair.

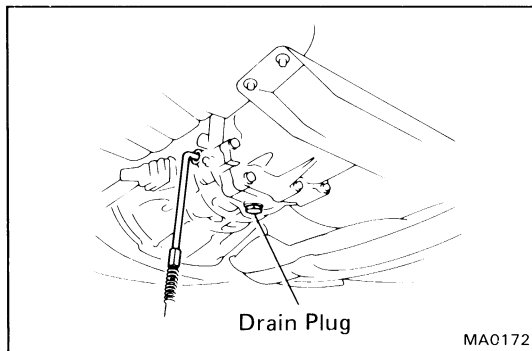

Drain Plug

MA0172

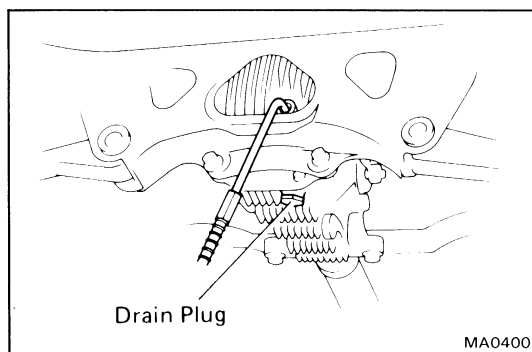

Drain Plug

MA0400

**21. REPLACE MANUAL TRANSMISSION AND DIFFERENTIAL OIL**

- (a) Remove the drain plug and drain the oil.
- (b) Clean the drain plug.
- (c) Reinstall drain plug securely.
- (d) Add new oil until it begins to run out of the filler hole.

**Transmission oil—**

**Oil grade: API GL-4 or GL-5**

**Viscosity:**

**7M-GE SAE 75W—90 or 80W—90**

**7M-GTE SAE 75W—90**

**Capacity:**

**7M-GE 2.4 liters  
(2.5 US qts, 2.1 Imp. qts)**

**7M-GTE 3.0 liters  
(3.2 US qts, 2.6 Imp. qts)**

**Differential oil—**

**Oil grade: API GL-5 hypoid gear oil or for LSD oil (LSD only)**

**Viscosity: Above —18°C (0°F) SAE 90**

**Below —18°C (0°F) SAE 80W—90**

**Capacity: 1.3 liters (1.4 US qts, 1.1 Imp. qts)**

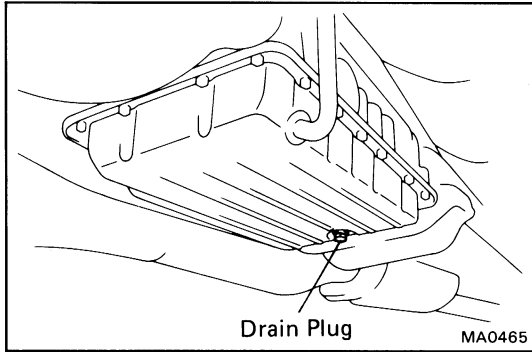

## 22. REPLACE AUTOMATIC TRANSMISSION FLUID

- (a) Remove the drain plug and drain the fluid.
- (b) Reinstall the drain plug securely.
- (c) With the engine "OFF", add new fluid through the dipstick tube.

**Fluid: ATF DEXRON® II**

**Drain and refill capacity (Reference):**

**1.6 liters (1.7 US qts, 1.4 Imp. qts)**

- (d) Start the engine and shift the selector into all positions from "P" through "L", and then shift into "P".
- (e) With the engine idling, check the fluid level. Add fluid up to the "COOL" level on the dipstick.

**NOTICE: Do not overfill.**

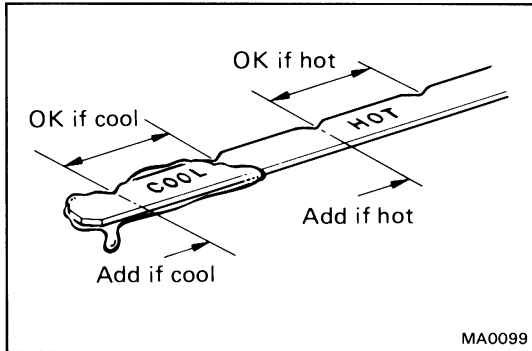

## 23. TIGHTEN BOLTS AND NUTS ON CHASSIS AND BODY

Tighten the following parts:

- Front seat mounting bolts

**Torque: 375 kg-cm (27 ft-lb, 37 N·m)**

- Front suspension member-to-body mounting bolts and nuts.

**Torque: 1,300 kg-cm (94 ft-lb, 127 N·m)**

- Rear suspension member-to-body mounting bolts and nuts.

**Torque: 1,840 kg-cm (133 ft-lb, 180 N·m)**

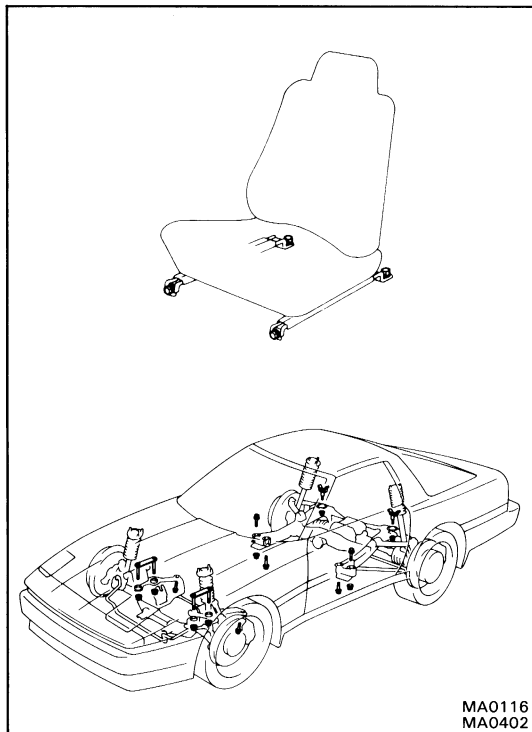

**24. FINAL INSPECTION**

- (a) Check the operation of the body parts:
  - Hood
    - Auxiliary catch operates properly
    - Hood locks securely when closed
  - Front and back doors
    - Door locks operate properly
    - Doors close properly
  - Seats
    - Seat adjusts easily and locks securely in any position
    - Front seat back locks securely in any position
    - Folding-down rear seat backs lock securely
- (b) Road test
  - Check the engine and chassis for abnormal noises.
  - Check that the vehicle does not wander or pull to one side.
  - Check that the brakes work properly and do not drag.
  - Perform setting down of the parking brake shoes and drum. (See page MA-10)
- (c) Be sure to deliver a clean car and especially check:
  - Steering wheel
  - Shift lever knob
  - All switch knobs
  - Door handles
  - Seats

## GENERAL MAINTENANCE

These are the maintenance and inspection items which are considered to be the owner's responsibility. They can be performed by the owner or he can have them done at a service shop. These items include those which should be checked on a daily basis, those which, in most cases, do not require (special) tools and those which are considered to be reasonable for the owner to perform.

Items and procedures for general maintenance are as follows.

### OUTSIDE VEHICLE

#### 1. TIRES

- (a) Check the pressure with a gauge. If necessary, adjust.
- (b) Check for cuts, damage or excessive wear.

#### 2. WHEEL NUTS

When checking the tires, check the nuts for looseness or for missing nuts. If necessary, tighten them.

#### 3. TIRE ROTATION

It is recommended that tires be rotated every 7,500 miles (12,000 km).

#### 4. WINDSHIELD WIPER BLADES

Check for wear or cracks whenever they do not wipe cleanly. If necessary, replace.

#### 5. FLUID LEAKS

- (a) Check underneath for leaking fuel, oil, water or other fluid.
- (b) If you smell gasoline fumes or notice any leak, have the cause found and corrected.

#### 6. DOORS AND ENGINE HOOD

- (a) Check that all doors including the trunk lid, back door and tailgate operate smoothly, and that all latches lock securely.
- (b) Check that the engine hood secondary latch secures the hood from opening when the primary latch is released.

### INSIDE VEHICLE

#### 7. LIGHTS

- (a) Check that the headlights, stop lights, taillights, turn signal lights, and other lights are all working.
- (b) Check the headlight aim.

#### 8. WARNING LIGHTS AND BUZZERS

Check that all warning lights and buzzers function properly.

#### 9. HORN

Check that it is working.

#### 10. WINDSHIELD GLASS

Check for scratches, pits or abrasions.

#### 11. WINDSHIELD WIPER AND WASHER

- (a) Check operation of the wipers and washer.
- (b) Check that the wipers do not streak.

#### 12. WINDSHIELD DEFROSTER

Check that air comes out from the defroster outlet when operating the heater or air conditioner.

#### 13. REAR VIEW MIRROR

Check that it is mounted securely.

#### 14. SUN VISORS

Check that they move freely and are mounted securely.

#### 15. STEERING WHEEL

Check that it has specified freeplay. Be alert for changes in steering condition, such as hard steering, excessive freeplay or strange noise.

#### 16. SEATS

- (a) Check that all front seat controls such as seat adjusters, seatback recliner, etc. operate smoothly.
- (b) Check that all latches lock securely in any position.
- (c) Check that the locks hold securely in any latched position.
- (d) Check that the head restraints move up and down smoothly and that the locks hold securely in any latched position.
- (e) For folding-down rear seat backs, check that the latches lock securely.

#### 17. SEAT BELTS

- (a) Check that the seat belt system such as buckles, retractors and anchors operate properly and smoothly.
- (b) Check that the belt webbing is not cut, frayed, worn or damaged.

**18. ACCELERATOR PEDAL**

Check the pedal for smooth operation and uneven pedal effort or catching.

**19. CLUTCH PEDAL (See page CL-3)**

Check the pedal for smooth operation.

Check that the pedal has the proper freeplay.

**20. BRAKE PEDAL (See page BR-5)**

(a) Check the pedal for smooth operation.

(b) Check that the pedal has the proper reserve distance and freeplay.

(c) Check the brake booster function.

**21. BRAKES**

At a safe place, check that the brakes do not pull to one side when applied.

**22. PARKING BRAKE (See page BR-7)**

(a) Check that the lever has the proper travel.

(b) On a safe incline, check that vehicle is held securely with only the parking brake applied.

**23. AUTOMATIC TRANSMISSION "PARK" MECHANISM**

(a) Check the lock release button of the selector lever for proper and smooth operation.

(b) On an safe incline, check that vehicle is held securely with the selector lever in "P" position and all brakes released.

**UNDER HOOD****24. WINDSHIELD WASHER FLUID**

Check that there is sufficient fluid in the tank.

**25. ENGINE COOLANT LEVEL**

Check that the coolant level is between the "FULL" and "LOW" lines on the see-through reservoir.

**26. RADIATOR AND HOSES**

(a) Check that the front of the radiator is clean and not blocked with leaves, dirt or bugs.

(b) Check the hoses for cracks, links, rot or loose connections.

**27. BATTERY ELECTROLYTE LEVEL**

Check that the electrolyte level of all battery cells is between the upper and lower level lines on the case. If level is low, add distilled water only.

**28. BRAKE AND CLUTCH FLUID LEVELS**

(a) Check that the brake fluid level is near the upper level line on the see-through reservoir.

(b) Check that the clutch fluid level is within  $\pm 5$  mm (0.20 in.) of the reservoir hem.

**29. ENGINE DRIVE BELTS**

Check all drive belts for fraying, cracks, wear or oiliness.

**30. ENGINE OIL LEVEL**

Check the level on the dipstick with the engine turned off.

**31. POWER STEERING FLUID LEVEL**

Check the level.

The level should be in the "HOT" or "COLD" range depending on the fluid temperature.

**32. AUTOMATIC TRANSMISSION FLUID LEVEL**

(a) Park the vehicle on a level surface.

(b) With the engine idling and the parking brake applied, shift the selector into all positions from "P" to "L", and then shift into "P".

(c) Pull out the dipstick and wipe off the fluid with a clean rag. Re-insert the dipstick and check that the fluid level is in the "HOT" range.

(d) Perform this check with the fluid at normal driving temperature (70 — 80°C or 158 — 176°F)

HINT: Wait about 30 minutes before checking the fluid level after extended driving at high speeds, in hot weather, in heavy traffic or with a trailer.

**33. EXHAUST SYSTEM**

Visually inspect for cracks, holes or loose supports.

If any change in the sound of the exhaust or smell of the exhaust fumes is noticed, have the cause located and corrected.

