ENGINE MECHANICAL

| | Page |
|---|-------|
| DESCRIPTION | EM-2 |
| TROUBLESHOOTING | EM-4 |
| ENGINE TUNE-UP | EM-7 |
| IDLE AND/OR 2,500 RPM HC/CO CONCENTRATION CHECK METHOD | EM-18 |
| COMPRESSION CHECK | EM-20 |
| TIMING BELT | EM-22 |
| CYLINDER HEAD | EM-32 |
| CYLINDER BLOCK | EM-63 |

EM

DESCRIPTION

The 7M-GE and 7M-GTE engines are an in-line 6-cylinder 3.0 liter DOHC 24 valve engine.

7M-GE

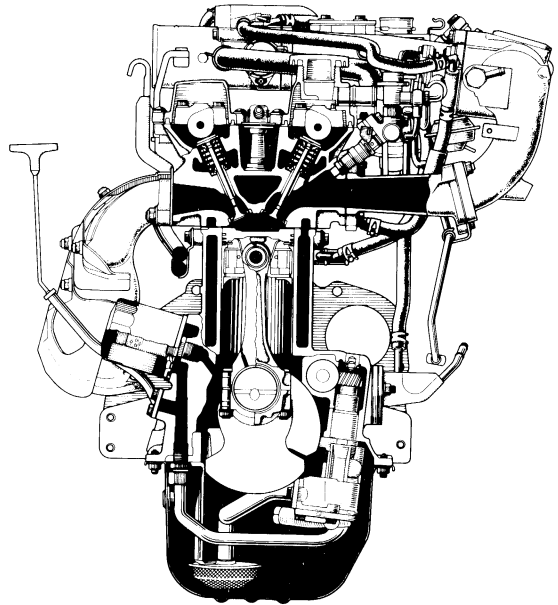
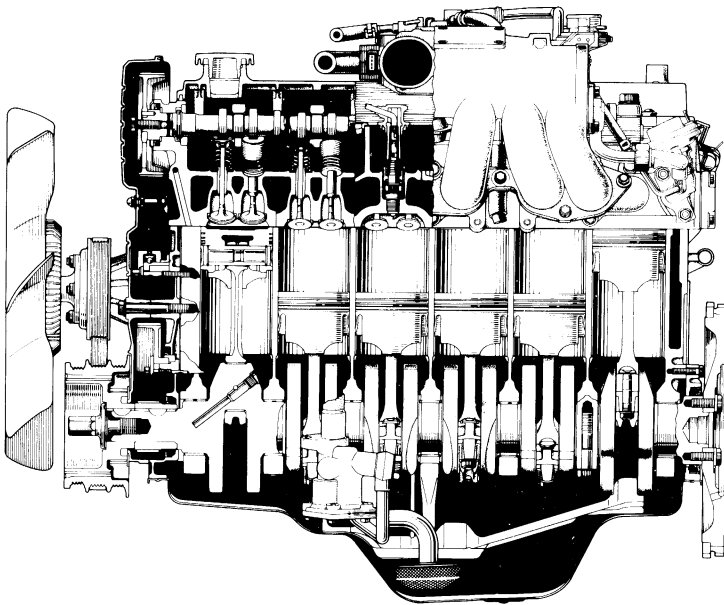

7M-GTE

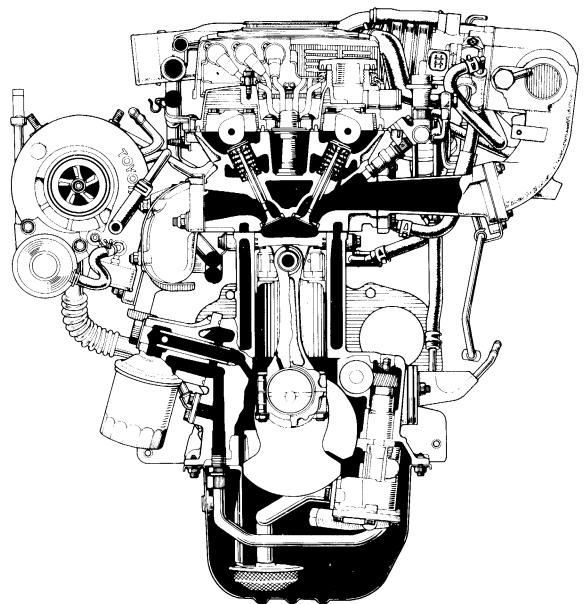
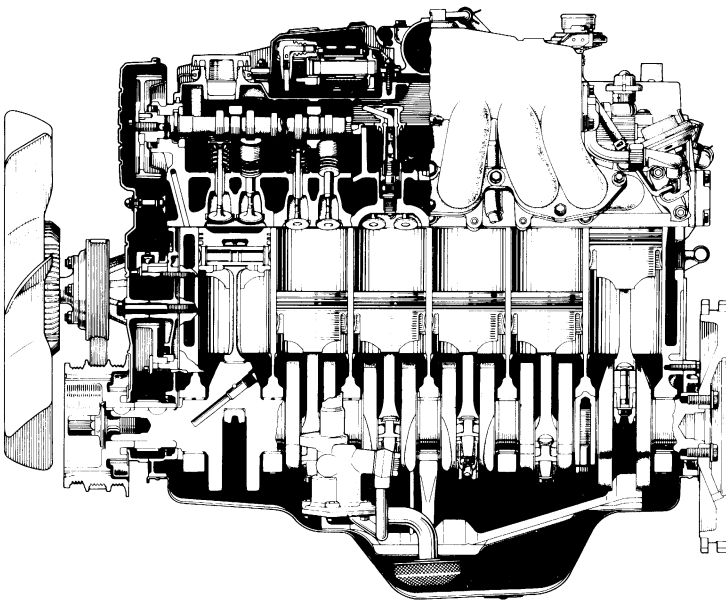

The 7M-GE, 7M-GTE engines are an in-line 6-cylinder engine with the cylinders numbered 1-2-3-4-5-6 from the front. The crankshaft is supported by 7 bearings specified by the inside of the crankcase. These bearings are made of kelmet.

The crankshaft is integrated with 12 weights which are cast along with it for balance. Oil holes are built into the crankshaft for supplying oil to the connecting rods, pistons and other components.

These engine's ignition order is 1-5-3-6-2-4. The cylinder head is made of aluminum alloy, with a cross flow type intake and exhaust layout and with pent roof type combustion chambers. The spark plugs are located in the center of the combustion chambers.

Exhaust and intake valves are equipped with irregular pitch springs with symmetrical ends made of oil tempered silicon chrome steel wire which are capable of following the valves even at high engine speeds.

Both the exhaust side cam shaft and the intake side cam shaft are driven by a single timing belt. The cam journal is supported at 7 places between the valve lifters of each cylinder and on the cylinder head of front end. Lubrication of the cam journal and cam is accomplished by oil being supplied through the oiler port in the center of the camshaft.

Adjustment of the valve clearance is done by means of an outer shim type system, in which valve adjusting shims are located above the valve lifters. This permits replacement of the shims without removal of the camshafts.

The resin timing belt cover is made in 2 pieces.

Pistons are made of high temperature-resistant aluminum alloy, and depressions are built into the piston head to prevent interference with valves.

Piston pins are the full-floating type, with the pins fastened to neither the piston boss nor the connecting rods. Instead, snap rings are fitted on both ends of the pins, preventing the pins from falling out.

The No. 1 compression ring is made of stainless steel and the No. 2 compression ring is made of cast iron. The oil ring is made of a combination of stainless steel. The outer diameter of each piston ring is slightly larger than the diameter of the piston and the flexibility of the rings allows them to hug the cylinder walls when they are mounted on the piston. Compression rings No. 1 and No. 2 work to prevent the leakage of gas from the cylinder and the oil ring works to scrape oil off the cylinder walls to prevent it from entering the combustion chamber.

The cylinder block is made of cast iron. It has 6 cylinders which are approximately 1.6 times the length of the piston stroke. The top of the cylinders is shut off by the cylinder head and the lower end of the cylinders becomes the crankcase, in which the crankshaft is installed. In addition, the cylinder block contains a water jacket through which coolant is pumped to cool the cylinders.

The oil pan is bolted to the bottom of the cylinder block. The oil pan is an oil reservoir made of pressed steel sheet. A dividing plate is included inside the oil pan to keep sufficient oil in the bottom of the pan even when the vehicle is tilted. This dividing plate also prevents the oil from making waves when the vehicle is stopped suddenly and thus shifting the oil away from the oil pump suction pipe.

TROUBLESHOOTING

| Problem | Possible cause | Remedy | Page |
|--|--|--|--|
| Engine overheats | Cooling system faulty Incorrect ignition timing | Troubleshoot cooling system Reset timing | CO-4 IG-20 |
| Engine will not crank or cranks slowly | Starting system faulty | Troubleshoot starting system | ST-2 |
| Engine will not start/ hard to start (cranks OK) | Vacuum leaks <ul style="list-style-type: none"> ● PCV hoses ● EGR valve ● Intake manifold ● Air intake chamber ● Throttle body ● ISC valve Pulling in air between air flow meter and throttle body Ignition problems <ul style="list-style-type: none"> ● Ignition coil ● Igniter ● (7M-GE) Distributor (7M-GTE) Cam position sensor High-tension cord disconnected or broken No fuel supply to injector <ul style="list-style-type: none"> ● No fuel in tank ● Fuel pump not working ● Fuel filter clogged ● Fuel line clogged or leaking EFI system problems ISC system problem Spark plugs faulty Low compression | Repair as necessary Repair as necessary Perform spark test Inspect cord Troubleshoot EFI system Repair as necessary Check ISC system Inspect plugs Check compression | IG-5, 10 IG-6, 11 FI-10 FI-106 IG-7 EM-20, 21 |
| Rough idle, stalls or misses | Vacuum leaks <ul style="list-style-type: none"> ● PCV hoses ● EGR valve ● Intake manifold ● Air intake chamber ● Throttle body ● ISC valve Pulling in air between air flow meter and throttle body Incorrect idle speed Incorrect ignition timing Ignition problems <ul style="list-style-type: none"> ● Ignition coil ● Igniter ● (7M-GE) Distributor (7M-GTE) Cam position sensor High-tension cord faulty EFI system problems | Repair as necessary Check ISC system Reset timing Perform spark test Inspect cord Repair as necessary | FI-106 IG-20 IG-5, 10 IG-6, 11 |

TROUBLESHOOTING (Cont'd)

| Problem | Possible cause | Remedy | Page |
|---|--|---|--|
| Rough idle, stalls or misses (cont'd) | Spark plugs faulty Engine overheats Low compression | Inspect plugs Check cooling system Check compression | IG-7 CO-4 EM-20, 21 |
| Engine hesitates/ poor acceleration | Vacuum leaks <ul style="list-style-type: none"> ● PCV hoses ● EGR valve ● Intake manifold ● Air intake chamber ● Throttle body ● ISC valve Pulling in air between air flow meter and throttle body Incorrect ignition timing Emission control system problem (cold engine) <ul style="list-style-type: none"> ● EGR system always on High-tension cord faulty Fuel system clogged Air cleaner clogged EFI system problems Spark plugs faulty Engine overheats Low compression | Repair as necessary Repair as necessary Reset timing Check EGR system Inspect cord Check fuel system Check air cleaner Repair as necessary Inspect plugs Check cooling system Check compression | IG-20 EC-12, 16 IG-6, 11 FI-70 MA-5 IG-7 CO-4 EM-20, 21 |
| Engine diesels (runs after ignition switch is turned off) | EFI system problems | Repair as necessary | |
| Muffler explosion (after fire) on deceleration only | Deceleration fuel cut system always off | Check EFI (fuel cut) system | FI-124 |
| Muffler explosion (after fire) all the time | Air cleaner clogged EFI system problem Incorrect ignition timing | Check air cleaner Repair as necessary Reset timing | MA-5 IG-20 |
| Engine backfires | Vacuum leak <ul style="list-style-type: none"> ● PCV hoses ● EGR valve ● Intake manifold ● Air intake chamber ● Throttle body ● ISC valve Pulling in air between air flow meter and throttle body EFI system problem Insufficient fuel flow Incorrect ignition timing Carbon deposits in combustion chambers | Check hoses and repair as necessary Repair as necessary Repair as necessary Troubleshoot fuel system Reset timing Inspect cylinder head | IG-20 EM-32 |

TROUBLESHOOTING (Cont'd)

| Problem | Possible cause | Remedy | Page | |
|---------------------------|---|----------------------------------|--|--------|
| Excessive oil consumption | Oil leak | Repair as necessary | LU-7 | |
| | PCV line clogged | Check PCV system | EC-5 | |
| | Piston rings worn or damaged | Check rings | EM-63 | |
| | Valve stem and guide worn | Check valves | EM-32 | |
| | Valve stem seal worn | Check seals | EM-32 | |
| Poor fuel economy | Fuel leak | Repair as necessary | MA-5 IG-20 | |
| | Air cleaner clogged | Check air cleaner | | |
| | Incorrect ignition timing | Reset timing | | |
| | EFI system problems <ul style="list-style-type: none"> ● Injector faulty ● Deceleration fuel cut system faulty | Repair as necessary | FI-106 IG-7 EC-12, 16 EM-20, 21 | |
| | Idle speed too high | Check ISC system | | |
| | Spark plugs faulty | Inspect plugs | | |
| | EGR system always on | Check EGR system | | |
| | Low compression | Check compression | | |
| | Tires improperly inflated | Inflate tires to proper pressure | | |
| | Clutch slips | Troubleshoot clutch | | |
| | Brakes drag | Troubleshoot brakes | | |
| Unpleasant odor | Incorrect idle speed | Check ISC system | | FI-106 |
| | Incorrect ignition timing | Reset timing | | IG-20 |
| | Vacuum leaks <ul style="list-style-type: none"> ● PCV hoses ● EGR valve ● Intake manifold ● Air intake chamber ● Throttle body | Repair as necessary | | |
| | EFI system problems | Repair as necessary | | |

ENGINE TUNE-UP

INSPECTION OF ENGINE COOLANT

(See page CO-5)

INSPECTION OF ENGINE OIL

(See page LU-4)

INSPECTION OF AIR FILTER

(See page MA-5)

INSPECTION OF BATTERY

(See page CH-2)

INSPECTION OF HIGH-TENSION CORDS

(See pages IG-6, 11)

INSPECTION OF SPARK PLUGS

(See page IG-7)

INSPECTION OF DRIVE BELTS

(See page MA-4)

INSPECTION OF IGNITION TIMING

(See page IG-20)

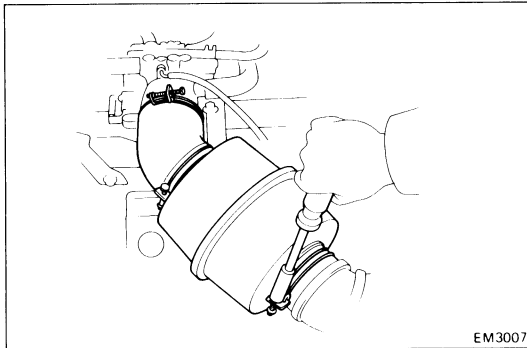

INSPECTION AND ADJUSTMENT OF VALVE CLEARANCE

HINT: Check and adjust the valve clearance while the engine is cold.

(7M-GE)

1. **DRAIN COOLANT**
(See page CO-5)
2. **REMOVE NO. 1 AIR CLEANER HOSE WITH AIR CONNECTOR PIPE**
3. **REMOVE AIR INTAKE CONNECTOR**
 - (a) Disconnect following cables:
 - Cruise control cable
 - Accelerator cable
 - (A/T) Throttle cable
 - (b) Remove the PCV pipe.
 - (c) Disconnect the accelerator rod.
 - (d) Disconnect the water by-pass hoses from the throttle body.

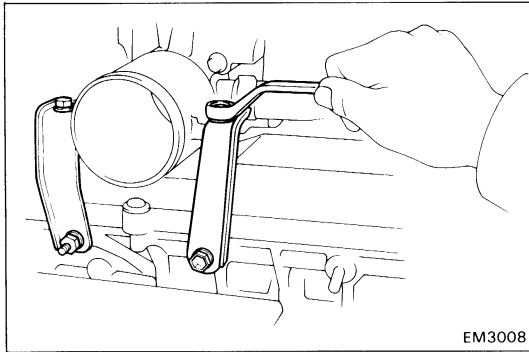

EM3008

- (e) Disconnect following hoses:
- VSV hose (for EGR)
 - BSVV hose
 - EGR vacuum modulator hoses
 - No.7 air hose
- (f) Disconnect the throttle position sensor connector.
- (g) Remove the throttle body brackets.

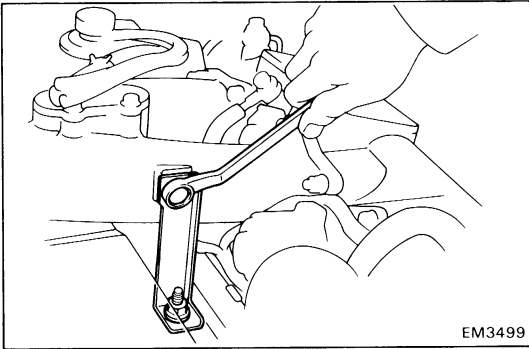

EM3499

- (h) Remove the air intake connector bracket mounting bolts.

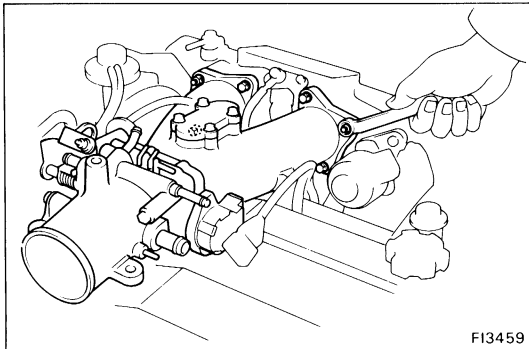

FI3459

- (i) Remove the four bolts, two nuts, air intake connector and gasket.

4. REMOVE CYLINDER HEAD COVERS

(See step 15 on page EM-39)

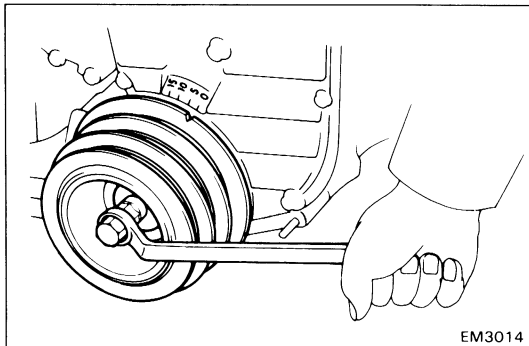

EM3014

5. MEASURE VALVE CLEARANCE

- (a) Set No.1 cylinder to TDC/compression.
- Turn the crankshaft pulley and align its groove with the "O" mark on the No.1 timing belt cover.
 - Check that the valve lifters on the No.1 cylinder are loose and valve lifters on the No.6 cylinder are tight.

If not, turn the crankshaft pulley one complete revolution.

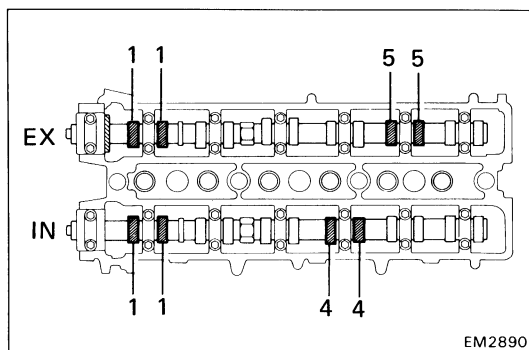

EM2890

- (b) Measure the clearance of No.1 (IN) and No.4 (IN) and No.1 (EX) and No.5 (EX) valves.
- Measure only those valves indicated in the figure.
 - Record the measurements which are out of specification. They will be used later to determine the required replacement shims.

Valve clearance (Cold):

Intake 0.15 — 0.25 mm (0.006 — 0.010 in.)

Exhaust 0.20 — 0.30 mm (0.008 — 0.012 in.)

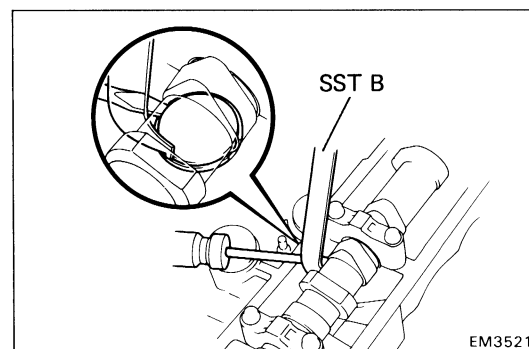
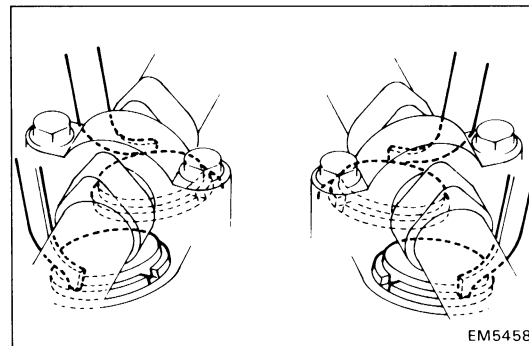
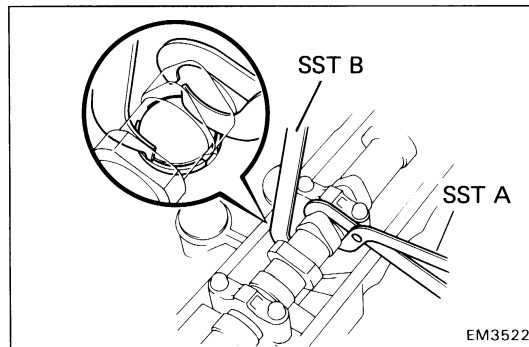
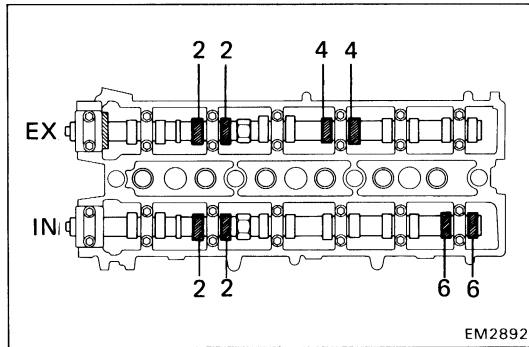
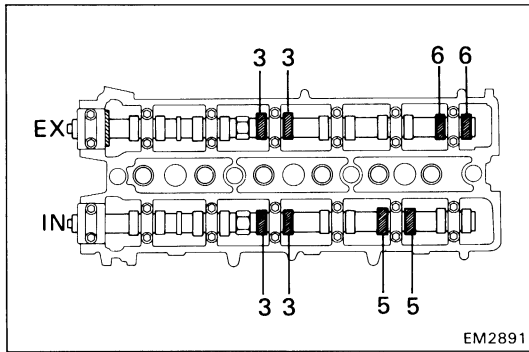

- (c) Turn the crankshaft pulley $2/3$ revolution (240°) and measure the clearance of No.3 (IN) and No.5 (IN) and No.3 (EX) and No.6 (EX) valves.
- Check that the valve lifters on the No.3 cylinder are loose.
 - Measure only those valves indicated in the figure.
 - Record the measurements which are out of specification. They will be used later to determine the required replacement shims.

- (d) Turn the crankshaft pulley $2/3$ revolution (240°) and measure the clearance of No.2 (IN) and No.6 (IN) and No.2 (EX) and No.4 (EX) valves.
- Check that the valve lifters on the No.2 cylinder are loose.
 - Measure only those valves indicated in the figure.
 - Record the measurements which are out of specification. They will be used later to determine the required replacement shims.

6. ADJUST VALVE CLEARANCE

- (a) Remove the adjusting shim.
- Turn the crankshaft to position the cam lobe of the camshaft on the adjusting valve upward.
 - Position the valve lifter notch so that the shim can be removed with a small screwdriver.
 - Using SST (A), press down the valve lifter and place SST (B) between the camshaft and valve lifter. Remove SST (A).

SST 09248-55010

HINT: For easy removal of the shim, when positioning SST (B), set it on the lifter so there is space enough to be able to remove the shim.

- Remove the adjusting shim with a small screwdriver and magnetic finger.

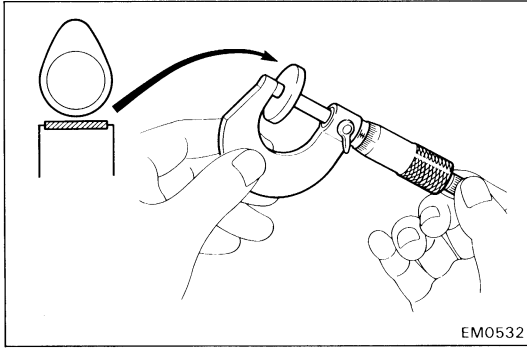

(b) Determine the replacement shim size by using the following (Formula or Chart).

- Using a micrometer, measure the thickness of the shim which was removed.
- Calculate the thickness of the new shim so the valve clearance comes within specified value.

TThickness of shim used

AValve clearance measured

NThickness of shim new

Intake side: $N = T + [A - 0.20 \text{ mm (0.0079 in.)}]$

Exhaust side: $N = T + [A - 0.25 \text{ mm (0.0098 in.)}]$

- Select a new shim with a thickness as close as possible to the calculated value.

HINT: Shims are available in 17 sizes, in increments of 0.050 mm (0.0020 in.), from 2.500 mm (0.0984 in.) to 3.300 mm (0.1299 in.).

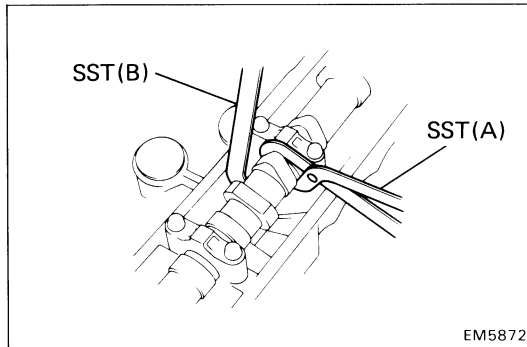

(c) Install the new adjusting shim.

- Place the new adjusting shim on the valve lifter.
- Using SST (A), press down the valve lifter and remove SST (B).

SST 09248-55010

(d) Recheck the valve clearance.

7. INSTALL CYLINDER HEAD COVERS (See step 4 on pages EM-55, 56)

8. INSTALL AIR INTAKE CONNECTOR

(a) Install a new gasket and air intake connector with the four bolts and two nuts.

Torque: 180 kg-cm (13 ft-lb, 18 N·m)

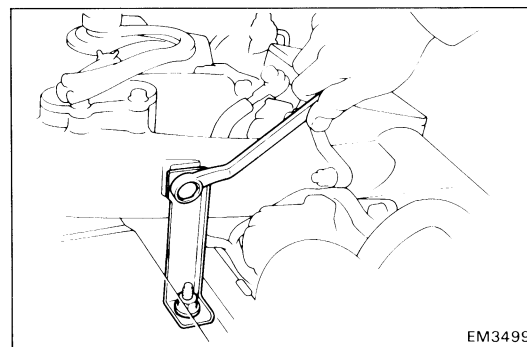
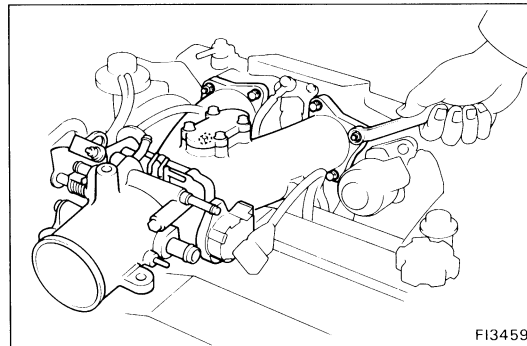

(b) Install the air intake connector bracket mounting bolts.

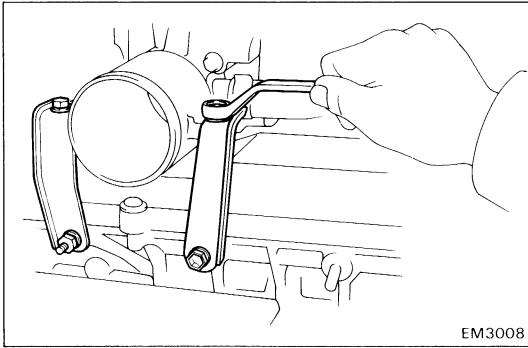

- (c) Install the throttle body brackets.
- (d) Connect the throttle position sensor connector.
- (e) Connect following hoses:
 - No. 7 air hose
 - EGR vacuum modulator hoses
 - BVSV hose
 - VSV hose (for EGR)
- (f) Connect the water by-pass hoses.
- (g) Connect the accelerator connecting rod.
- (h) Install the PCV pipe.
- (i) Connect following cables:
 - (A/T)
Throttle cable
 - Accelerator cable
 - Cruise control cable

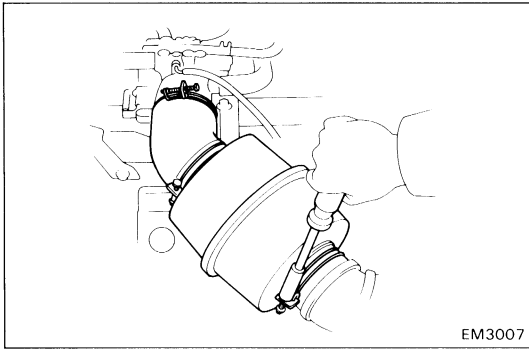

- 9. **INSTALL NO. 1 AIR CLEANER HOSE WITH AIR CONNECTOR PIPE**
- 10. **FILL WITH COOLANT**
(See page CO-5)

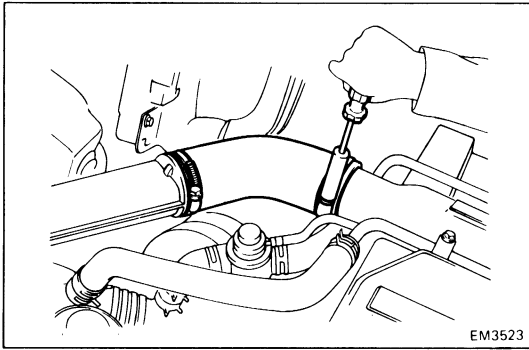
**(7M-GTE)****1. REMOVE NO.1 AIR CLEANER HOSE****2. DISCONNECT FOLLOWING CABLES AND ROD:**

- (a) Accelerator link w/ cable
- (b) Accelerator rod
- (c) (A/T)
Throttle cable

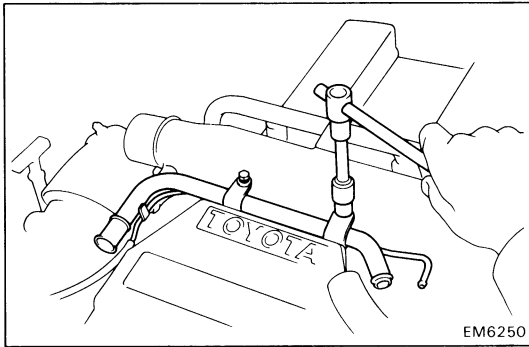
**3. REMOVE ISC PIPE**

- (a) Disconnect the six hoses from ISC pipe.
- (b) Remove the two bolts and ISC pipe.

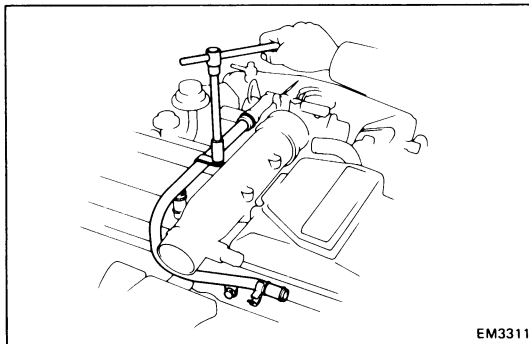
**4. REMOVE PCV PIPE WITH HOSES**

- (a) Disconnect the oxygen sensor wire from the two clamps.
- (b) Disconnect the No.4 PCV hose from the PCV pipe.
- (c) Remove the two bolts.
- (d) Disconnect the PCV pipe with hoses from the cylinder head covers and throttle body.

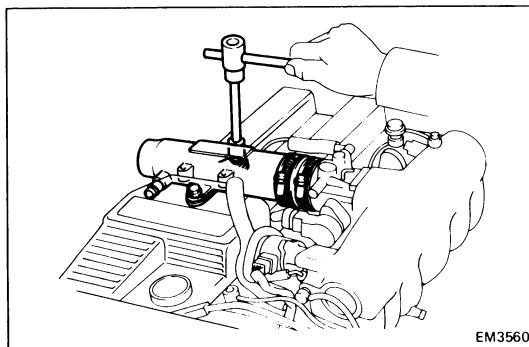
**5. REMOVE INTAKE AIR CONNECTOR**

- (a) Disconnect the air valve hose from intake air connector.
- (b) Loosen the clamp and remove the two bolt.
- (c) Remove the intake air connector.

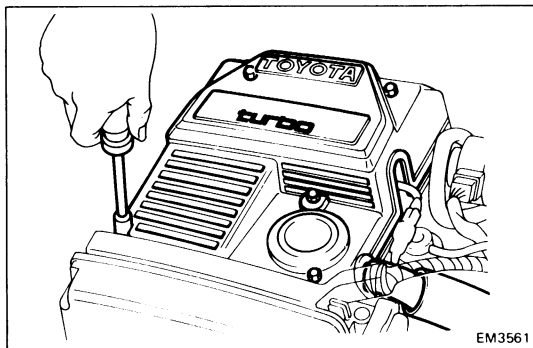
**6. REMOVE IGNITION COIL COVER**

- (a) Remove the oil filler cap.
- (b) Remove the five nuts and ignition coil cover.

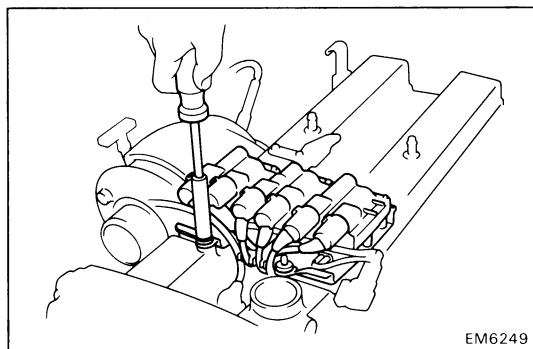
**7. REMOVE IGNITION COIL WITH BRACKET**

- (a) Disconnect the connector and ground strap.
- (b) Remove the nut.
- (c) Remove the No.1 and No.2 high-tension cords from ignition coil and clamp.
- (d) Remove the ignition coil with bracket and high-tension cords.
- (e) Remove the No.1 and No.2 high-tension cords from spark plugs.

8. REMOVE CYLINDER HEAD COVERS

- (a) Remove the accelerator link.
- (b) Disconnect the No.3 PCV hose.
- (c) Remove the cylinder head covers.

9. MEASURE VALVE CLEARANCE
(See step 5 on pages EM-8, 9)**10. ADJUST VALVE CLEARANCE**
(See step 6 on pages EM-9, 10)**11. RECHECK VALVE CLEARANCE****12. INSTALL CYLINDER HEAD COVERS**
(See step 4 on pages EM-55, 56)**13. INSTALL IGNITION COIL WITH BRACKET**

- (a) Install the No.1 and No.2 high-tension cords to spark plugs.
- (b) Install the ignition coil with bracket and high-tension cords.
(See page IG-13)
- (c) Install the No.1 and No.2 high-tension cords to ignition coil and clamp.

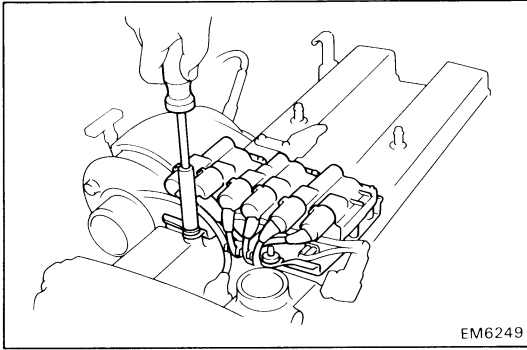

(d) Install and torque the nut.

Torque: 55 kg-cm (48 in-lb, 5.4 N·m)

HINT: Do not over tighten the nut.

(e) Connect the ground strap and connector.

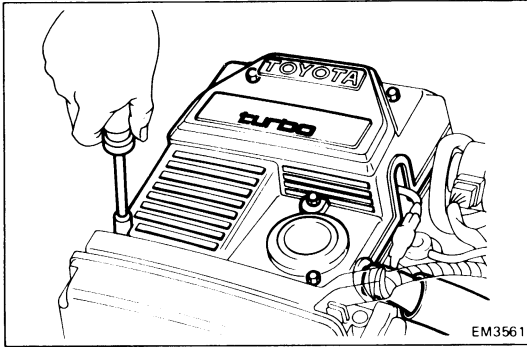

14. INSTALL IGNITION COIL COVER

(a) Install the ignition coil cover with five nuts.

(b) Install the oil filler cap.

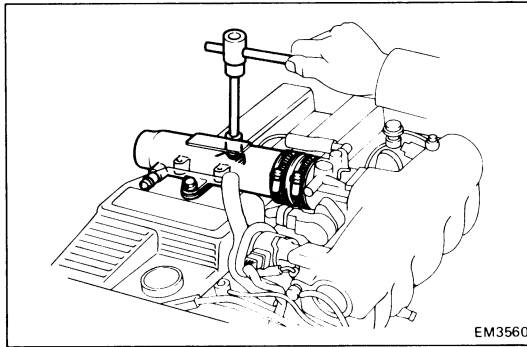

15. INSTALL INTAKE AIR CONNECTOR

(a) Install the intake air connector to throttle body.

(b) Install and tighten the two bolts.

(c) Tighten the clamp.

(d) Connect the air valve hose to intake air connector.

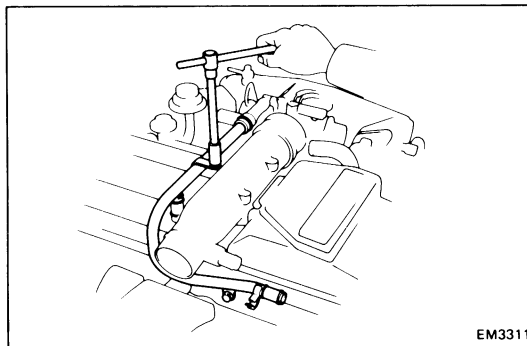

16. INSTALL PCV PIPE WITH HOSES

(a) Install the PCV pipe with hoses to throttle body and cylinder head covers.

(b) Install and tighten the two bolts.

(c) Connect the No.4 PCV hose to the PCV pipe.

(d) Connect the oxygen sensor wire to the two clamps.

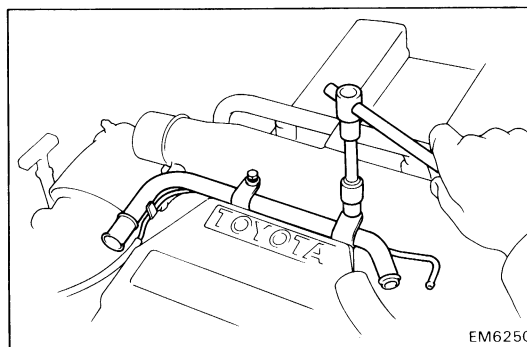

17. INSTALL ISC PIPE

(a) Install the ISC pipe with two bolts.

(b) Connect the six hoses to ISC pipe.

18. CONNECT FOLLOWING CABLES AND ROD:

- (a) (A/T)
Throttle cable
- (b) Accelerator rod
- (c) Accelerator link w/ cable

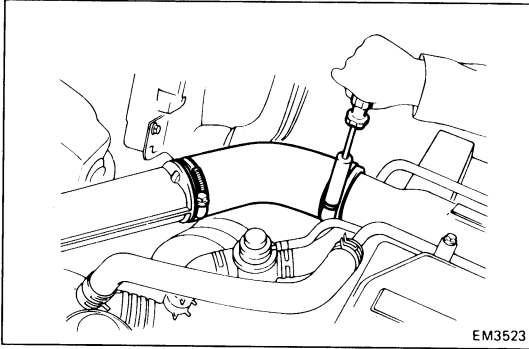
**19. INSTALL NO.1 AIR CLEANER HOSE**

IDLE AND/OR 2,500 RPM HC/CO CONCENTRATION CHECK METHOD

NOTE: This check is used only to determine whether or not the idle and/or 2,500 rpm HC/CO complies with regulations.

1. INITIAL CONDITIONS

- (a) Engine at normal operating temperature
- (b) Air cleaner installed
- (c) All pipes and hoses of air induction system connected
- (d) All accessories switched OFF
- (e) All vacuum lines properly connected

HINT: All vacuum hoses for EGR systems, etc. should be properly connected.

- (f) EFI system wiring connectors fully plugged
- (g) Ignition timing set correctly
- (h) Transmission in neutral
- (i) Tachometer and HC/CO meter calibrated and at hand.

2. START ENGINE

3. RACE ENGINE AT 2,500 RPM FOR APPROX. 2 MINUTES

4. INSERT HC/CO METER TESTING PROBE INTO TAILPIPE AT LEAST 40 cm (1.3 ft)

5. CHECK HC/CO CONCENTRATION AT IDLE AND/OR 2,500 RPM

Complete the measuring within three minutes.

NOTE: When performing the 2 mode (2,500 rpm and idle) test, follow the measurement order prescribed by regulations.

If the HC/CO concentration at 2,500 rpm does not comply with regulations, try the following procedure.

Race the engine again at 2,500 rpm for approx. 1 minute, and quickly repeat steps 4 and 5 above. This may correct the problem.

Troubleshooting

If the HC/CO concentration does not comply with regulations, perform troubleshooting in the order given below.

1. Check oxygen sensor operation.
(See page FI-119)
2. See the table below for possible causes, and then inspect and correct the applicable causes if necessary.

| HC | CO | Symptoms | Causes |
|------|--------|--|--|
| High | Normal | Rough idle | 1. Faulty ignition: <ul style="list-style-type: none"> • Incorrect timing • Fouled, shorted or improperly gapped plugs • Open or crossed high-tension cords • Cracked distributor cap 2. Incorrect valve clearance 3. Leaky EGR valve 4. Leaky intake and exhaust valves 5. Leaky cylinder |
| High | Low | Rough idle (Fluctuating HC reading) | 1. Vacuum leak: <ul style="list-style-type: none"> • Vacuum hose • EGR valve • Intake manifold (Air intake chamber) • Throttle body • ISC valve • Brake booster line 2. Lean mixture causing misfire |
| High | High | Rough idle (Black smoke from exhaust) | 1. Restricted air filter 2. Faulty EFI system: <ul style="list-style-type: none"> • Faulty pressure regulator • Clogged fuel return line • Faulty air flow meter • Defective water temp. sensor • Defective air temp. sensor • Faulty ECU • Faulty injector • Faulty cold start injector • Faulty throttle position sensor |

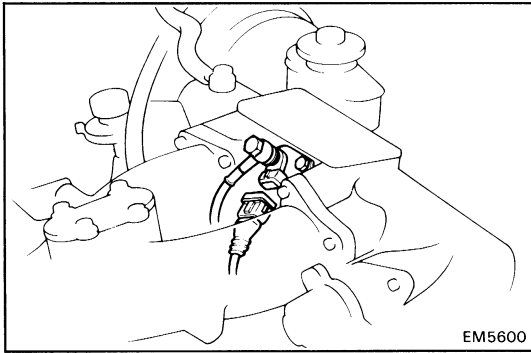

COMPRESSION CHECK

HINT: If there is lack of power, excessive oil consumption or poor fuel economy, measure the cylinder compression pressure.

(7M-GE)

1. **WARM UP ENGINE**
2. **DISCONNECT COLD START INJECTOR CONNECTOR**
3. **DISCONNECT HIGH-TENSION CORD FROM IGNITION COIL**
4. **REMOVE THROTTLE BODY**
 - (a) Remove the PCV hose.
 - (b) Disconnect the water by-pass hoses and plug the hose end.
 - (c) Disconnect following hoses:
 - VSV hose (for EGR)
 - BVSV hose
 - EGR vacuum modulator hoses
 - No.7 air hose
 - (d) Disconnect the throttle position sensor connector.
 - (e) Remove the throttle body bracket.
 - (f) Remove the four bolts, throttle body and gasket.

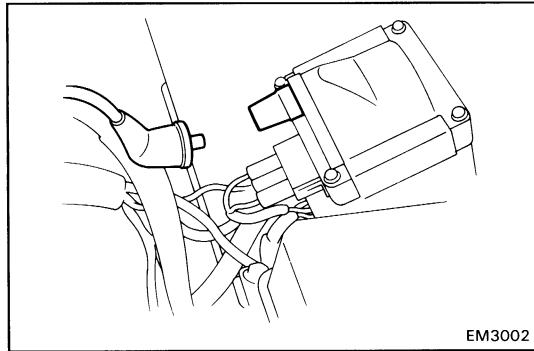

5. **REMOVE SPARK PLUGS**
6. **CHECK CYLINDER COMPRESSION PRESSURE**

- (a) Insert a compression gauge into the spark plug hole.
- (b) While cranking the engine with the starter motor, measure the compression pressure.

HINT: Always use a fully charged battery to obtain engine speed of 250 rpm or more.

- (c) Repeat steps (a) through (b) for each cylinder.

Compression pressure:

11.0 kg/cm² (156 psi, 1,079 kPa) or more

Minimum pressure:

9.0 kg/cm² (128 psi, 883 kPa)

Difference between each cylinder:

1.0 kg/cm² (14 psi, 98 kPa) or less

- (d) If cylinder compression in one or more cylinders is low, pour a small amount of engine oil into the cylinder through the spark plug hole and repeat steps (a) through (b) for the cylinder with low compression.
 - If adding oil helps the compression, chances are that the piston rings and/or cylinder bore are worn or damaged.
 - If pressure stays low, a valve may be sticking or seating improperly, or there may be leakage past the gasket.

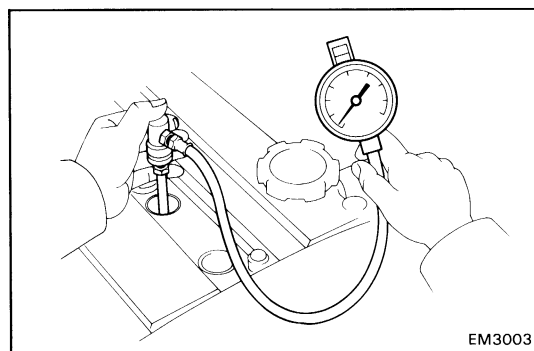

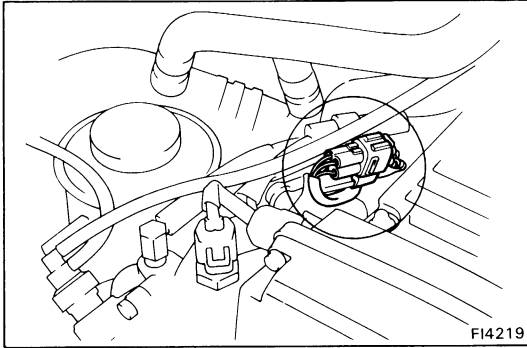
**(7M-GTE)**

1. WARM UP ENGINE
2. DISCONNECT CAM POSITION SENSOR CONNECTOR

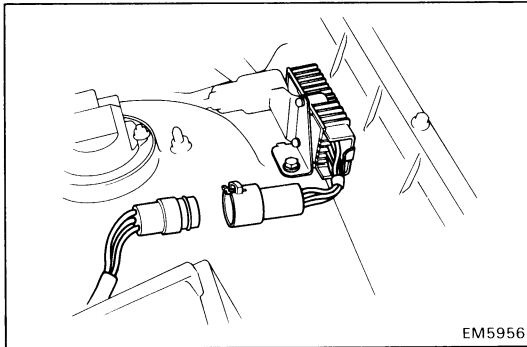

3. DISCONNECT SOLENOID RESISTOR CONNECTOR

4. REMOVE NO.1 AIR CLEANER HOSE
(See step 1 on page EM-12)

5. REMOVE PCV PIPE

6. REMOVE IGNITION COIL
(See steps 6, 7 on page EM-13)

7. REMOVE SPARK PLUGS

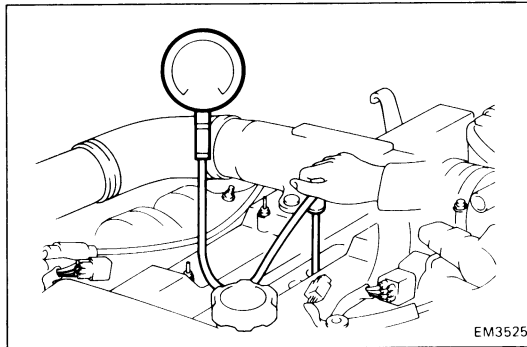

8. CHECK CYLINDER COMPRESSION PRESSURE
(See step 7 on page EM-20)

Compression pressure:

10.0 kg/cm² (142 psi, 981 kPa) or more

Minimum pressure:

9.0 kg/cm² (128 psi, 883 kPa)

Difference between each cylinder:

1.0 kg/cm² (14 psi, 98 kPa) or less

TIMING BELT COMPONENTS

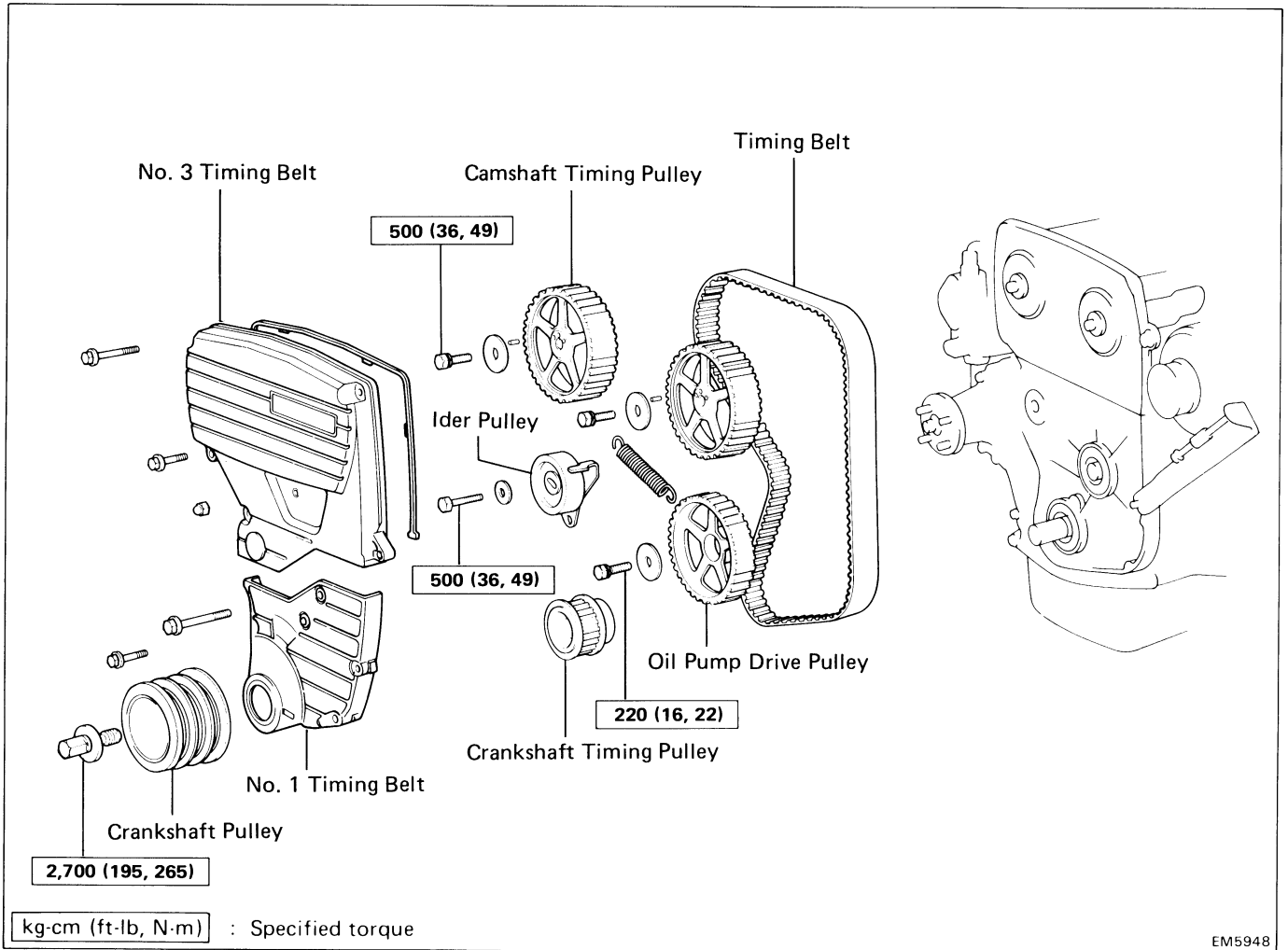

REMOVAL OF TIMING BELT

1. REMOVE RADIATOR
(See page CO-9)
2. REMOVE SPARK PLUGS

3. REMOVE WATER OUTLET

Remove the two bolts, water outlet and thermostat with gasket.

4. REMOVE A/C BELT

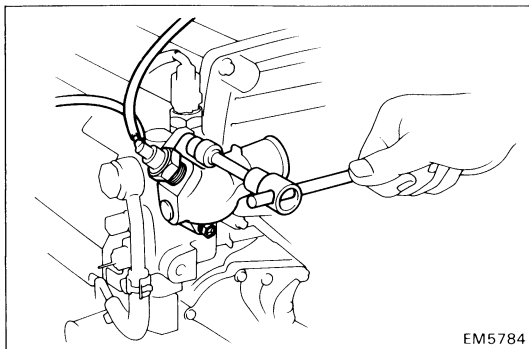

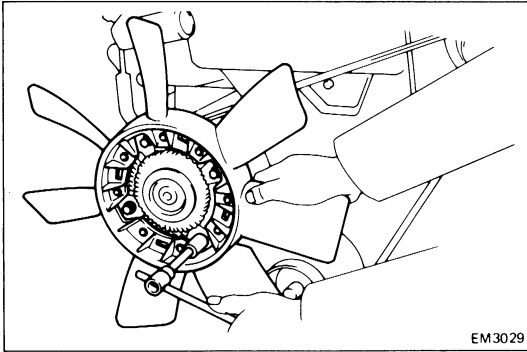

5. REMOVE FAN AND ALTERNATOR DRIVE BELT

6. REMOVE PS BELT

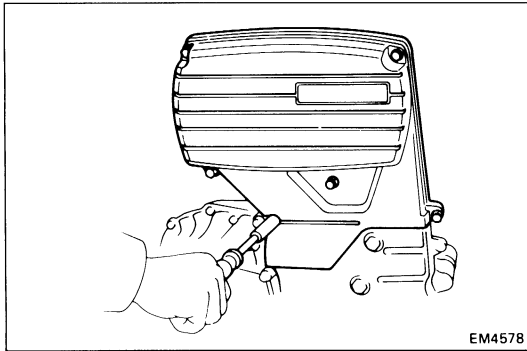

7. REMOVE NO.3 TIMING BELT COVER

Remove the five bolts, nut and No.3 timing belt cover with the gasket.

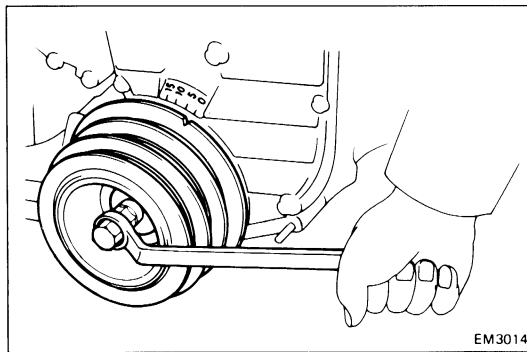

8. SET NO.1 CYLINDER TO TDC/COMPRESSION

(a) Turn the crankshaft pulley and align its groove with the "O" mark on the No.1 timing belt cover.

(b) Check that the matchmarks on the camshaft timing pulleys and No.2 timing belt cover are aligned.

If not, turn the crankshaft pulley one complete revolution.

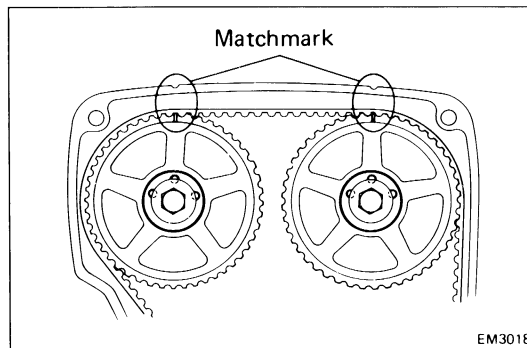

9. REMOVE TIMING BELT FROM CAMSHAFT TIMING PULLEYS

HINT: If reusing the timing belt, draw a direction arrow on the belt (in direction of engine revolution).

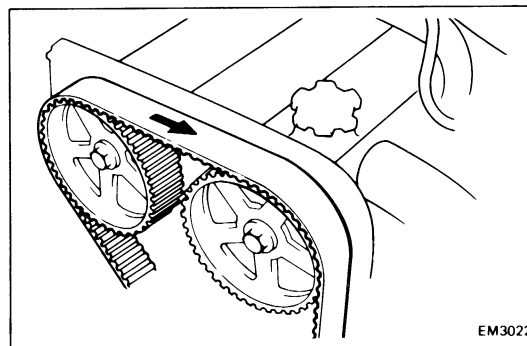

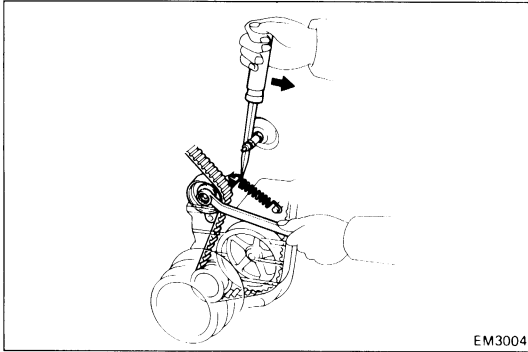

EM3004

- (a) Loosen the idler pulley bolt and shift it left as far as it will go with a screwdriver and wrench.
- (b) Temporarily tighten the set bolt and then relieve the timing belt tension.
- (c) Remove the belt from the camshaft timing pulleys.

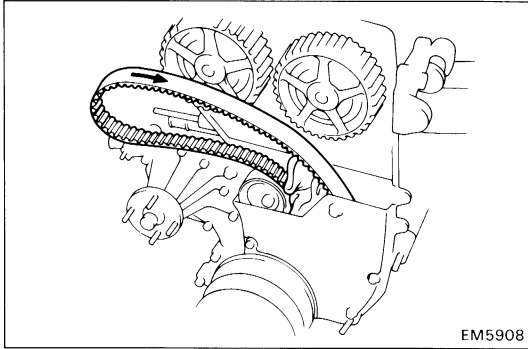

EM5908

HINT:

- Support the belt so the meshing of the crankshaft timing pulley and timing belt does not shift.
- Be careful not to drop anything inside the timing belt cover.
- Do not allow the belt to come into contact with oil, water and dust.

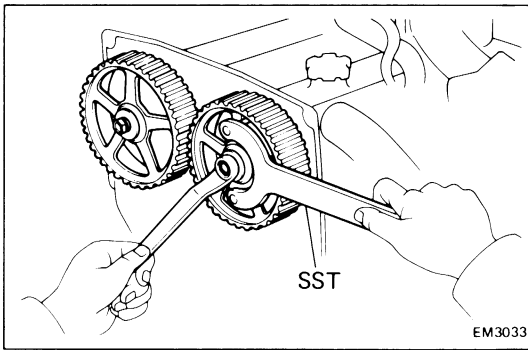

EM3033

10. REMOVE CAMSHAFT TIMING PULLEYS

Using SST to hold the pulley, remove the pulley bolt, timing pulley and match pin.

SST 09278-54012

HINT: Place the matchmarks on the camshaft timing pulley where the straight pin inserted.

NOTICE: Do not make use of the timing belt tension when removing and installing the pulley bolts.

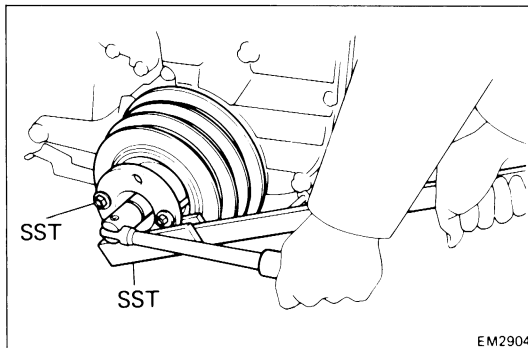

EM2904

11. REMOVE CRANKSHAFT PULLEY

- (a) Using SST to hold the crankshaft pulley, loosen the pulley bolt.

SST 09213-70010 and 09330-00021

- (b) Remove SST and pulley bolt.

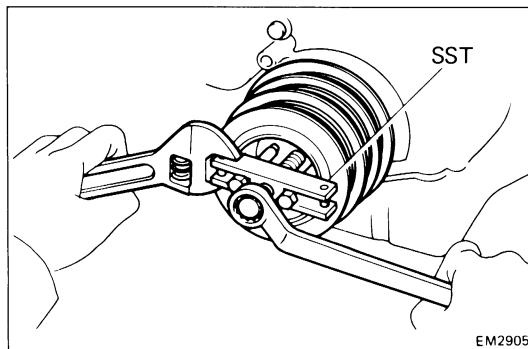

EM2905

- (c) Using SST, remove the pulley.

SST 09213-31021

12. REMOVE PS AIR PIPE

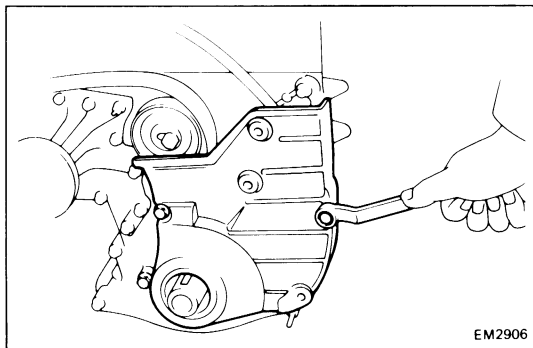
**13. REMOVE NO.1 TIMING BELT COVER**

- (a) Remove the A/C compressor without disconnecting hoses.
- (b) Remove the nine bolts, nut, A/C idler pulley bracket, compressor bracket and No.1 timing belt cover.

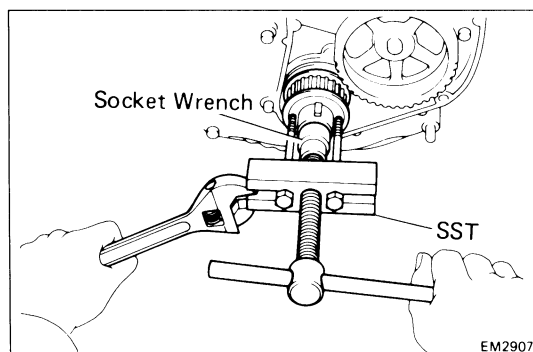
14. REMOVE TIMING BELT**15. REMOVE IDLER PULLEY AND TENSION SPRING****16. REMOVE CRANKSHAFT TIMING PULLEY**

Using SST and a socket wrench, remove the crankshaft timing pulley.

SST 09213-60017 (09213-00020, 09213-00030, 09213-00050)

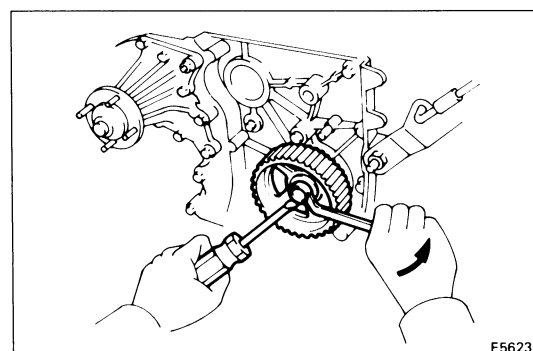
**17. REMOVE OIL PUMP DRIVE PULLEY**

Using a screwdriver to hold the pulley, remove the pulley bolt and pulley.

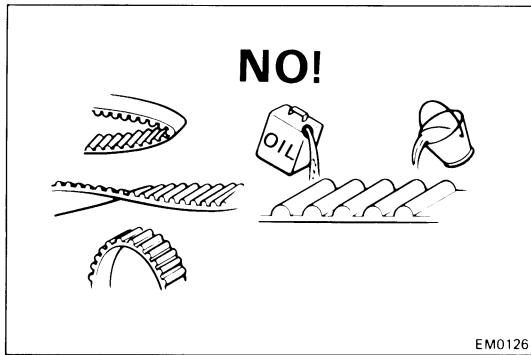

INSPECTION OF COMPONENTS

1. INSPECT TIMING BELT

NOTICE:

- Do not bend, twist or turn the belt inside out.
- Do not allow the belt to come into contact with oil, water or steam.
- Do not utilize belt tension when installing or removing the set bolt of the camshaft timing pulley.

If there are defects as shown in the illustrations. Check the following points and replace the timing belt if necessary.

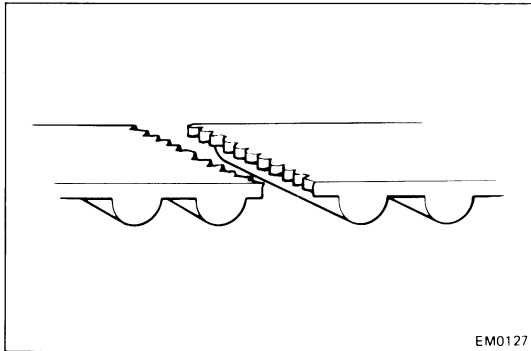

(a) Premature parting

- Check for proper installation.
- Check the timing belt cover gasket for damage and proper installation.

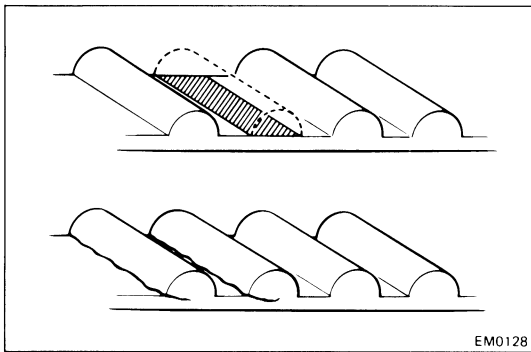

(b) If the belt teeth are cracked or damaged, check to see if the camshaft is locked.

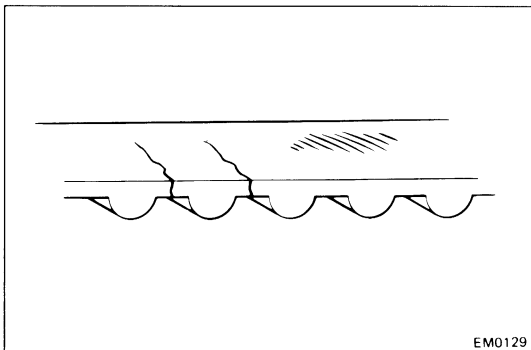

(c) If there is noticeable wear or cracks on the belt face, check to see if there are nicks on one side of the idler pulley lock.

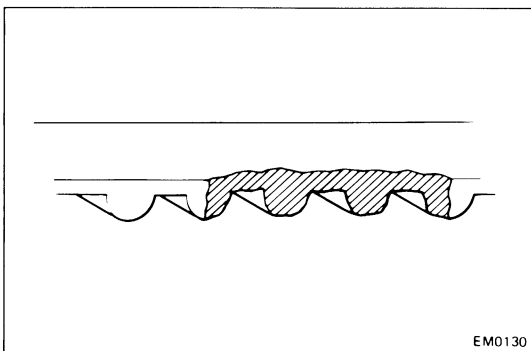

(d) If there is wear or damage on only one side of the belt, check the belt guide and the alignment of each pulley.

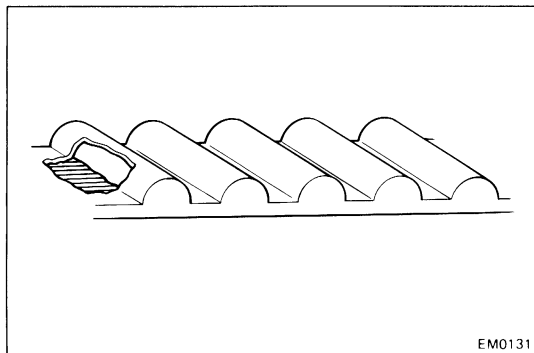

- (e) If there is noticeable wear on the belt teeth, check the timing belt cover gasket for damage and correct gasket installation. Check for foreign material on the pulley teeth.

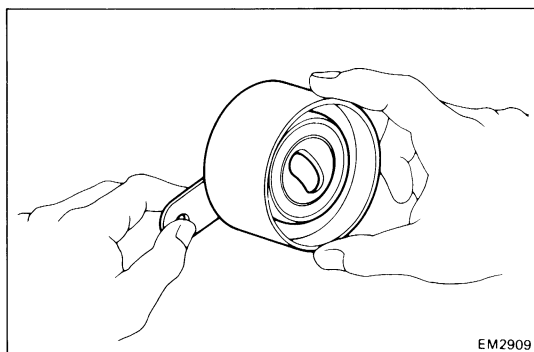

2. INSPECT IDLER PULLEY

Check the turning smoothness of the timing belt idler pulley. If necessary, replace the idler pulley.

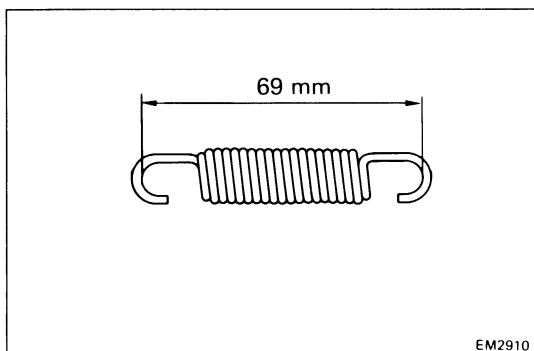

3. INSPECT TENSION SPRING

Check the free length of the spring.

Free length: 69 mm (2.72 in.)

If not as specified, replace the spring.

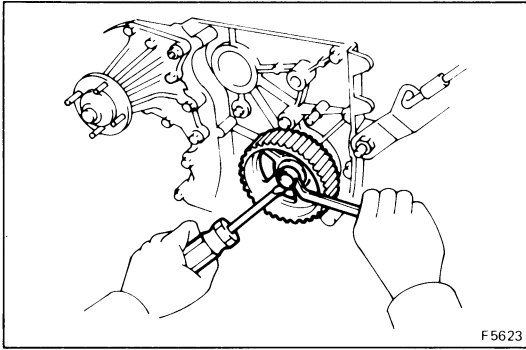

INSTALLATION OF TIMING BELT

(See page EM-22)

1. INSTALL OIL PUMP DRIVE PULLEY

- (a) Install the pulley and bolt.
- (b) Using a screwdriver to hold the pulley, torque the pulley bolt.

Torque: 220 kg-cm (16 ft-lb, 22 N·m)

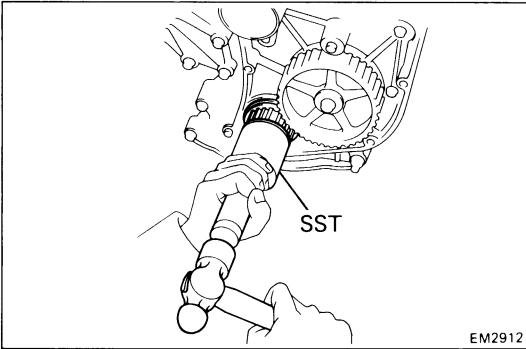

2. INSTALL CRANKSHAFT TIMING PULLEY

Using SST and hammer, drive in the pulley.

SST 09214-60010

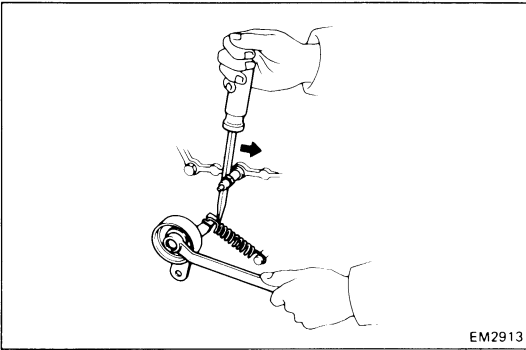

3. TEMPORARILY INSTALL IDLER PULLEY AND TENSION SPRING

- (a) Install the idler pulley and tension spring.
- (b) Pry the idler pulley toward the left as far as it will go and temporarily tighten it.

HINT: Remove any oil or water on the idler pulley and keep it clean.

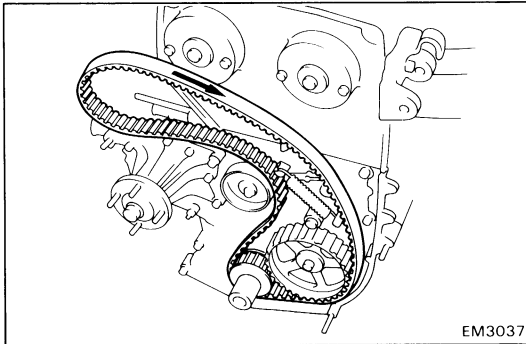

4. TEMPORARILY INSTALL TIMING BELT

NOTICE: The engine should be cold.

HINT: If reusing the timing belt, install it with the rotation direction mark pointing in the same direction as before disassembly.

Install the timing belt on the crankshaft timing pulley, oil pump drive pulley and idler pulley.

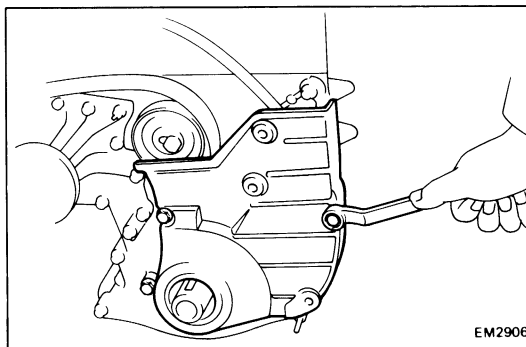

5. INSTALL NO.1 TIMING BELT COVER

- (a) Install the No.1 timing timing belt cover, A/C compressor bracket and idler pulley bracket with the nine bolts and two nuts.
- (b) Install the A/C compressor.

6. INSTALL PS AIR PIPE

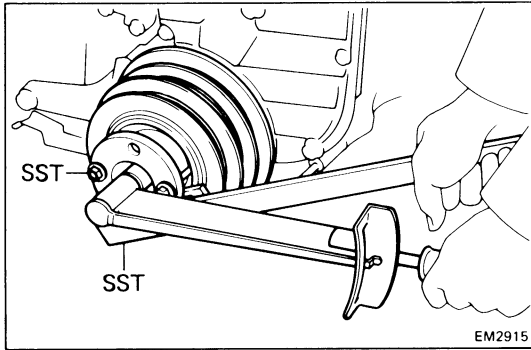

7. INSTALL CRANKSHAFT PULLEY

- (a) Align the pulley set key with the key groove of the pulley.
- (b) Install the pulley.
- (c) Using SST to hold the crankshaft pulley, install and torque the pulley bolt.

SST 09213-70010 and 09330-00021

Torque: 2,700 kg-cm (195 ft-lb, 265 N·m)

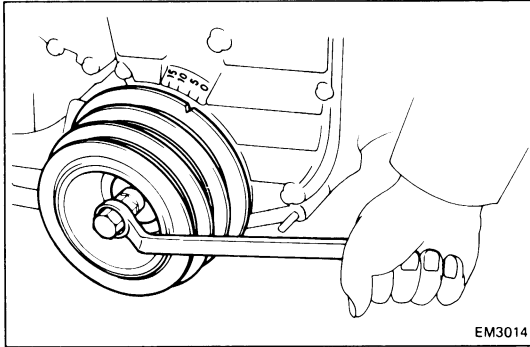

8. SET NO.1 CYLINDER TO TDC/COMPRESSION OF CRANKSHAFT

Turn the crankshaft pulley and align its groove with the "O" mark on the No.1 timing belt cover.

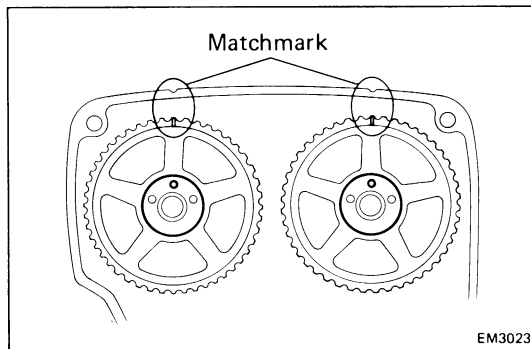

9. INSTALL CAMSHAFT TIMING PULLEYS

- (a) Align the timing pulley matchmark with the No.2 timing belt cover matchmark.
- (b) Install the timing pulley.
- (c) Install the pin to the hole.

HINT:

- When replacing the camshaft or the camshaft timing pulley:
Align the center holes of the camshaft and timing pulleys, as shown in the illustration and insert the straight pin.
 - When reusing the camshaft or camshaft timing pulleys:
Checking that the straight pin hole position is in the same position it was at disassembly, insert the straight pin.
- (d) Install the washer and pulley bolt.

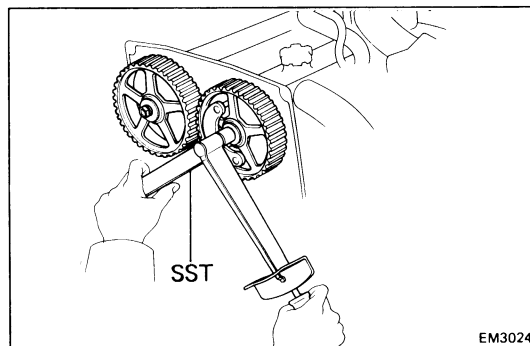

- (e) Using SST to hold the pulley, torque the pulley bolt.
SST 09278-54012

Torque: 500 kg-cm (36 ft-lb, 49 N·m)

- (f) Check that the matchmarks on the camshaft timing pulley are aligned with those on the No. 2 timing belt cover.

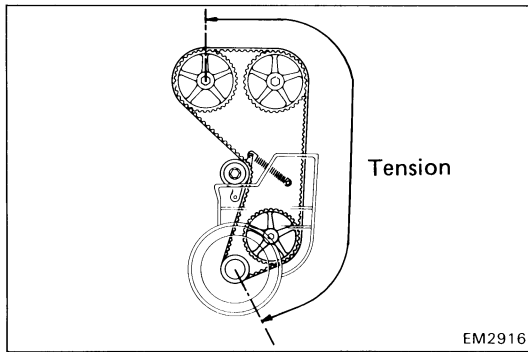

10. INSTALL TIMING BELT

- (a) Install the timing belt to the intake camshaft timing pulley, the exhaust camshaft timing pulley and then the idler pulley.
- (b) Check that the belt has tension as shown in the illustration.

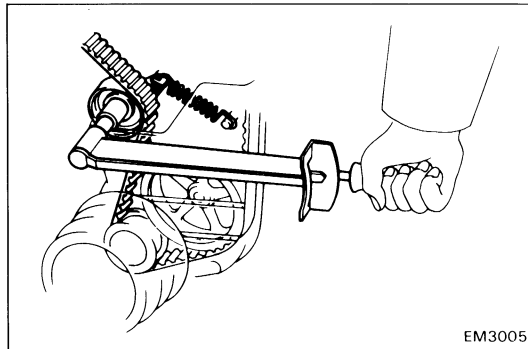

- (c) Loosen the idler pulley mount bolt until the pulley is moved slightly by the spring tension.
- (d) Torque the idler pulley mount bolt.

Torque: 500 kg-cm (36 ft-lb, 49 N·m)

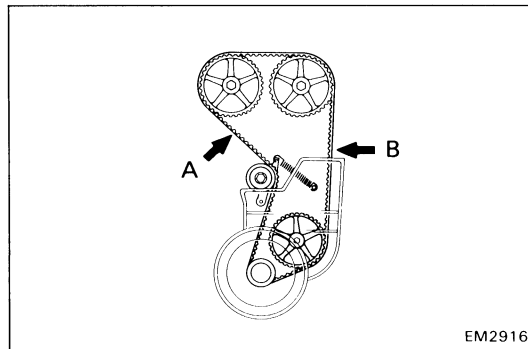

HINT: Check that the timing belt tension at A is equal to that at B.

If not, readjust with the idler pulley.

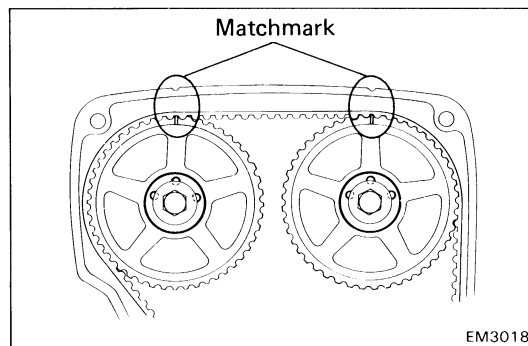

- (e) Turn the crankshaft pulley two revolutions clockwise from TDC to TDC.
- (f) Check that the matchmarks on the camshaft timing pulleys are aligned with those on the No.2 timing belt cover.

If the marks do not align, remove the timing belt and reinstall it.

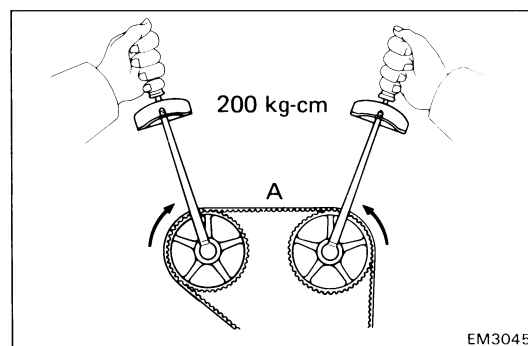

11. CHECK TIMING BELT TENSION

- (a) Turn both the intake and exhaust camshaft pulleys inward at the same time to slacken the timing belt at position A.

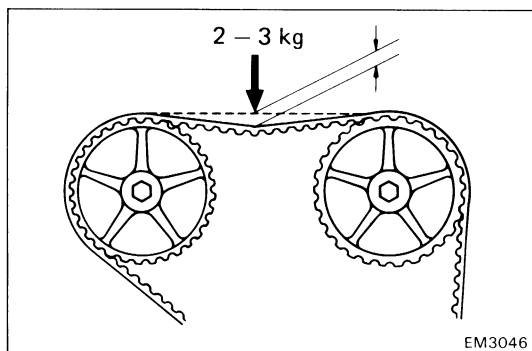

(b) Measure the timing belt deflection as shown.

Belt deflection at 2 – 3 kg (4.4 – 6.6 lb, 20 – 29 N):

Cold Used belt 5 – 7 mm (0.20 – 0.28 in.)

New belt 4 – 6 mm (0.16 – 0.24 in.)

Hot (Reference) 3 – 5 mm (0.12 – 0.20 in.)

If the measurement is not within specification, adjust by the idler pulley.

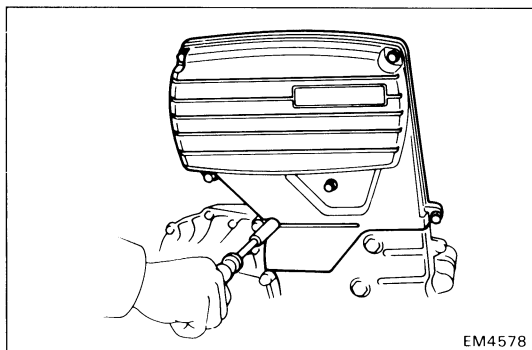

12. INSTALL NO.3 TIMING BELT COVER

Install the gasket and the belt cover with the five bolts and nut.

13. INSTALL PS BELT

(See page MA-4)

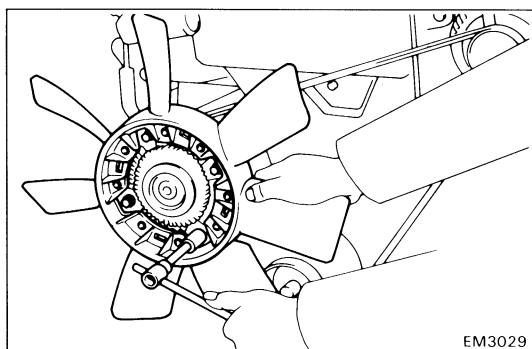

14. INSTALL ALTERNATOR DRIVE BELT AND FAN

Torque: Fan 55 kg-cm (48 in.-lb, 5.4 N·m)

Adjusting bolt 130 kg-cm (9 ft-lb, 5.4 N·m)

15. INSTALL A/C BELT

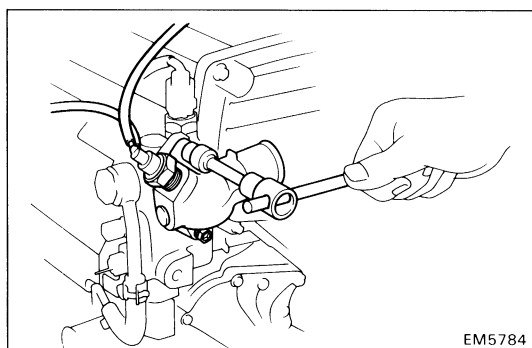

16. INSTALL WATER OUTLET

Install the thermostat with a new gasket and water outlet with the two bolts.

17. INSTALL SPARK PLUGS

18. INSTALL RADIATOR

(See page CO-14)

19. INSTALL NO.1 AIR CLEANER HOSE WITH INTAKE AIR CONNECTOR PIPE

20. START ENGINE

Warm up the engine and inspect for leaks.

21. ROAD TEST

Road test vehicle.

22. RECHECK COOLANT LEVEL

(See page CO-5)

CYLINDER HEAD COMPONENTS

7M-GE

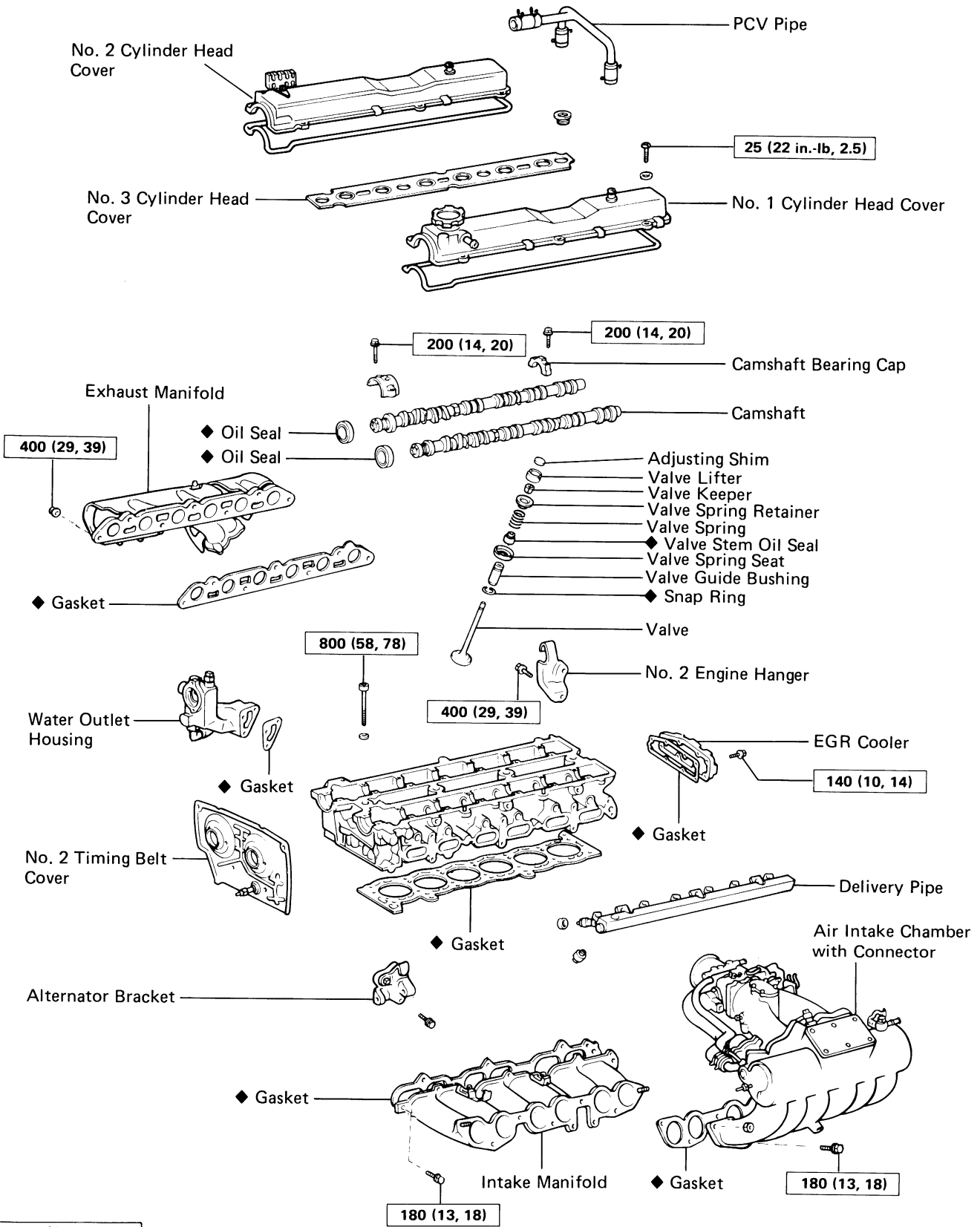

kg-cm (ft-lb, N·m) : Specified torque

◆ Non-reusable part

COMPONENTS (Cont'd)

7M-GTE

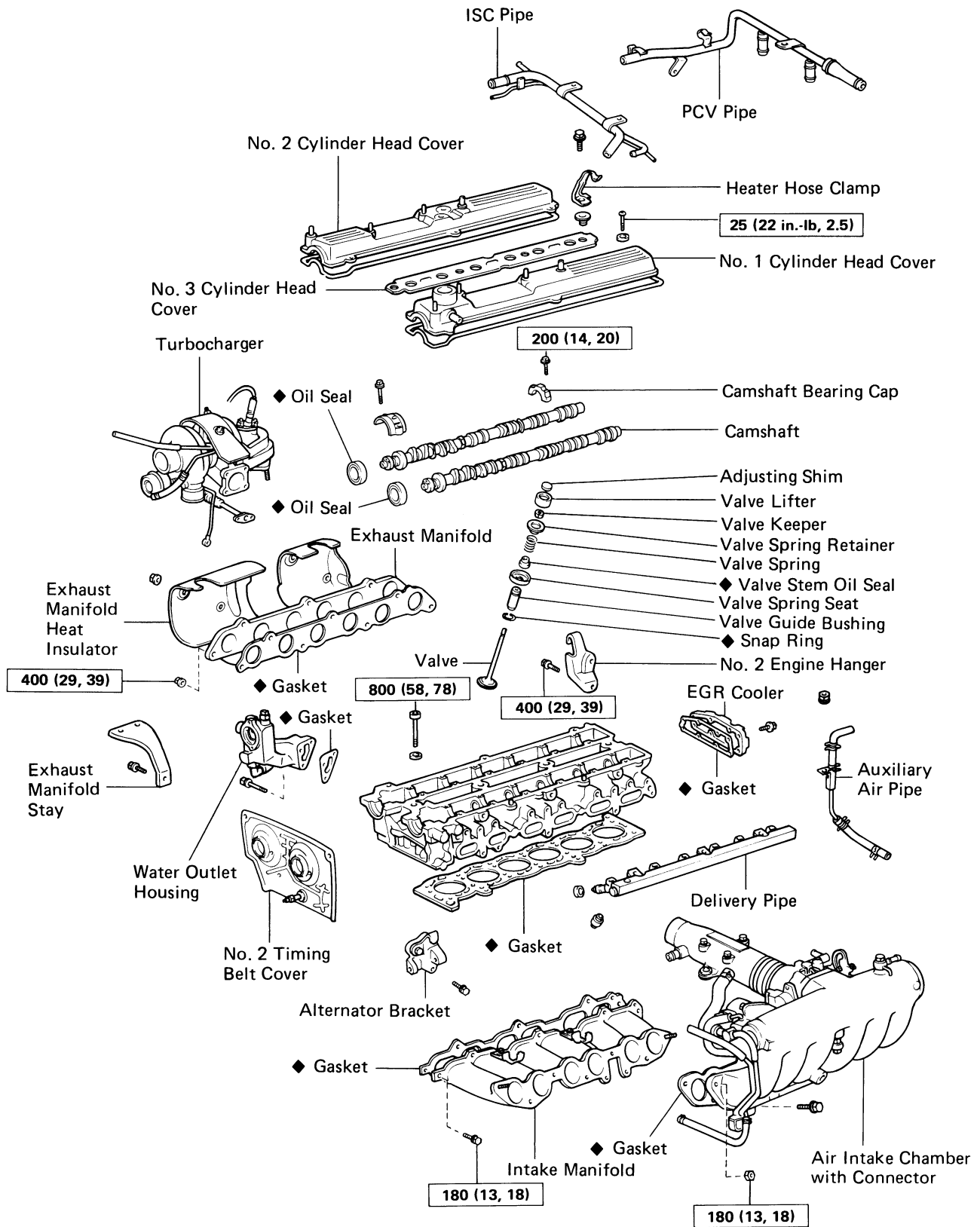

kg-cm (ft-lb, N-m) : Specified torque

◆ Non-reusable part

PREPARATION FOR REMOVAL

1. **DISCONNECT CABLE FROM NEGATIVE TERMINAL OF BATTERY**

CAUTION: Work must be started after approx. 20 seconds or longer from the time the ignition switch is turned to the "LOCK" position and the negative (—) terminal cable is disconnected from the battery.

2. **DRAIN COOLANT**
(See page CO-5)
3. **DISCONNECT EXHAUST PIPE FROM EXHAUST MANIFOLD**
4. **DISCONNECT FOLLOWING CABLE:**
 - (a) Accelerator link w/ cable
 - (b) Accelerator rod
 - (c) (A/T)
Throttle cable
5. **DISCONNECT GROUND STRAP FROM ENGINE REAR SIDE**

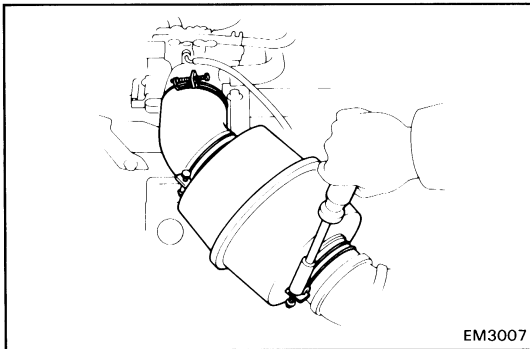

6. **(7M-GE)**
REMOVE NO.1 AIR CLEANER HOSE WITH INTAKE AIR CONNECTOR PIPE

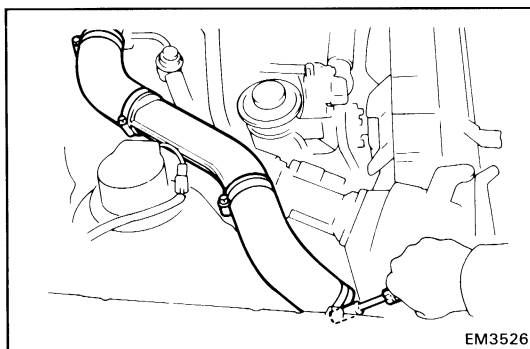

(7M-GTE)

REMOVE NO.4 AIR CLEANER PIPE WITH NO.1 AND NO.2 AIR CLEANER HOSES

7. **DISCONNECT FOLLOWING HOSES:**
 - (a) Cruise control vacuum hose
 - (b) Charcoal canister hose
 - (c) Brake booster hose
8. **REMOVE RADIATOR INLET HOSE**
9. **DISCONNECT HEATER INLET HOSE**

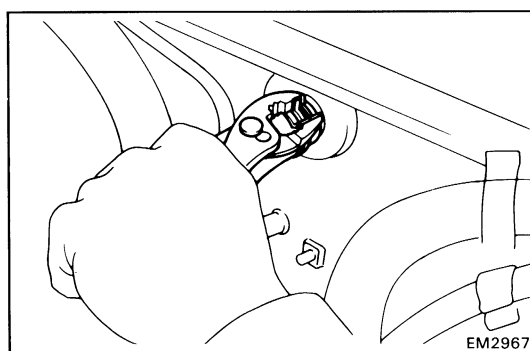

REMOVAL OF CYLINDER HEAD

(See pages EM-32, 33)

1. REMOVE ALTERNATOR

- (a) Disconnect the No.3 PCV hose.
- (b) Remove the drive belt.
- (c) Remove the alternator and adjusting bar.

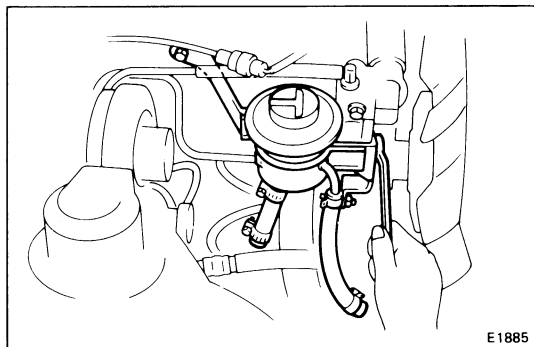
**2. (7M-GTE)****REMOVE PS RESERVOIR TANK**

Remove the two bolts, nut and reservoir tank with bracket.

3. (7M-GTE)**REMOVE CAM POSITION SENSOR****4. REMOVE AIR INTAKE CHAMBER WITH CONNECTOR**

- (a) Remove the PCV pipe.
- (b) Disconnect the following connectors:
 - (7M-GE)
Cold start injector connector
 - Throttle position sensor connector
 - ISC valve connector
- (c) Disconnect the following hoses:
 - BVSV hose from throttle body
 - EGR hoses from throttle body
 - Vacuum transmitting pipe hoses from intake chamber
 - Pressure regulator hose
 - PS air hose
 - (7M-GTE)
VSV hoses (for FPU)
 - (7M-GE)
Diaphragm hose
 - (7M-GTE)
Auxiliary air pipe hose from vacuum transmitting pipe hose
 - No.1 water by-pass hose from ISC valve
 - (7M-GE)
No.3 water by-pass hose from throttle body
 - (7M-GTE)
No.3 water by-pass hose from water by-pass pipe
- (d) Remove the EGR pipe mounting bolts.
- (e) Remove the manifold stay mounting bolts.

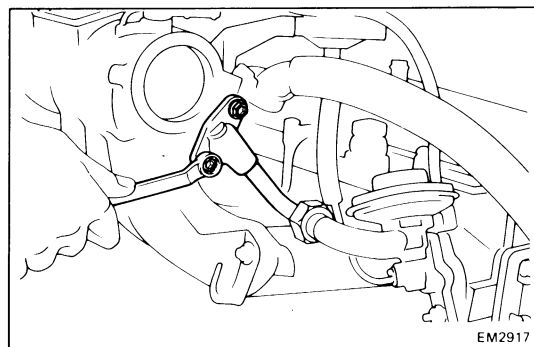

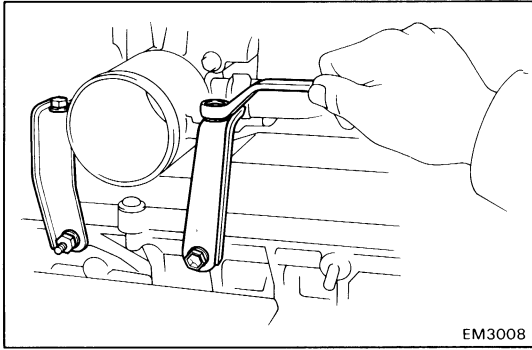

- (f) (7M-GE)
Remove the throttle body brackets.

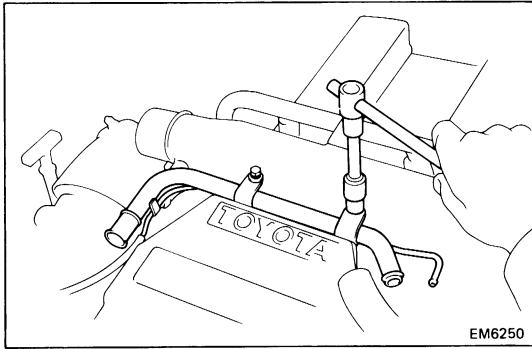

- (g) (7M-GTE)
Remove the ISC pipe.

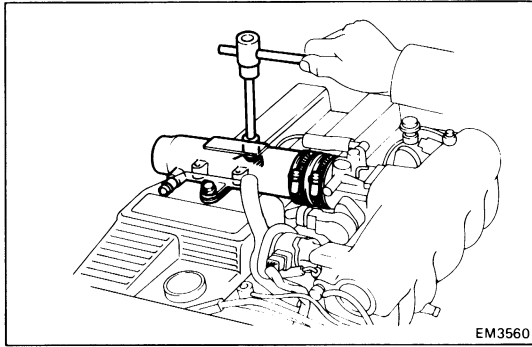

- (h) (7M-GTE)
Remove the air intake connector mounting bolts.

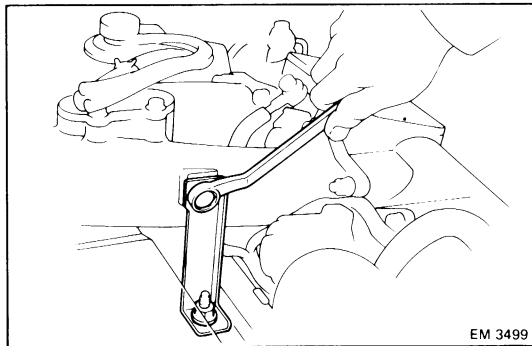

- (i) (7M-GE)
Remove the air intake connector bracket mounting bolts.
- (j) Remove the cold start injector tube.
- (k) Remove the EGR vacuum modulator from the bracket.
- (l) Disconnect the engine wire from the clamps of intake chamber.
- (m) Remove the two nuts, five bolts, vacuum transmitting pipes and intake chamber with connector and gasket.
- (n) (7M-GTE)
Disconnect the cold start injector connector.

5. (7M-GTE)

REMOVE IGNITION COIL WITH BRACKET
(See steps 6, 7 on page EM-13)

6. REMOVE ENGINE WIRE

- (a) Disconnect the following connectors and wire:
- Oxygen sensor connector
 - Oil pressure sender gauge connector
 - Water temp. sensor connector
 - Water temp. sender gauge connector
 - Cold start injector time switch connector
 - (7M-GE)
Distributor connector
 - Injector connectors
 - Two VSV connectors
 - Knock sensor connector(s)
 - Ground strap from intake manifold
 - Check connector
 - (7M-GTE)
Solenoid resister connector
 - (7M-GE)
Ignition coil connector
(7M-GTE)
Igniter connectors
 - Noise filter connector
 - Main relay connector
 - Starter connector (terminal 50)
 - Transmission connectors

- (b) Remove the engine wire from the four clamps.

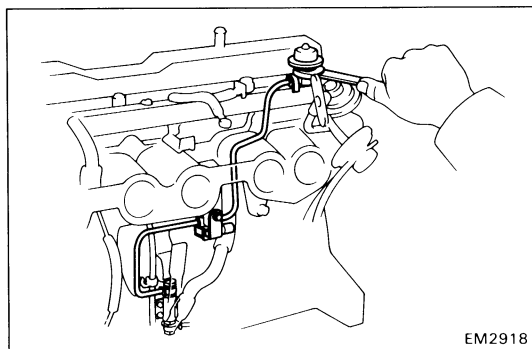
**7. REMOVE NO.1 FUEL PIPE**

- (a) Remove the union bolt (7M-GE) or pulsation damper (7M-GTE) and two gaskets from the delivery pipe.
- (b) Remove the union bolt and two gaskets from the fuel support.
- (c) Remove the clamp bolt and No. 1 fuel pipe with VSV.

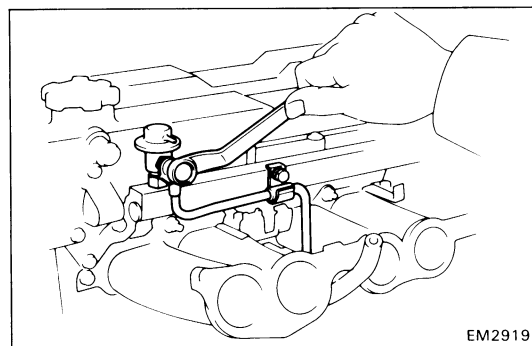
**8. REMOVE NO.2 FUEL PIPE**

- (a) Disconnect the fuel hose from the fuel support.
- (b) Remove the bolt, union bolt, No.2 fuel pipe and gaskets.

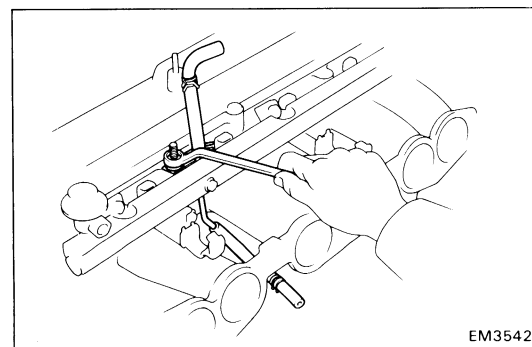
**9. (7M-GTE)
REMOVE AUXILIARY AIR PIPE****10. (7M-GE)
REMOVE HIGH-TENSION CORDS AND DISTRIBUTOR****11. (7M-GE)
REMOVE OIL DIPSTICK****12. (7M-GTE)
REMOVE TURBOCHARGER
(See steps 5 to 7 and 9 to 15 on pages TC-10 to 12)**

13. REMOVE EXHAUST MANIFOLD

- (a) (7M-GTE)
Remove the five nuts and heat insulators.

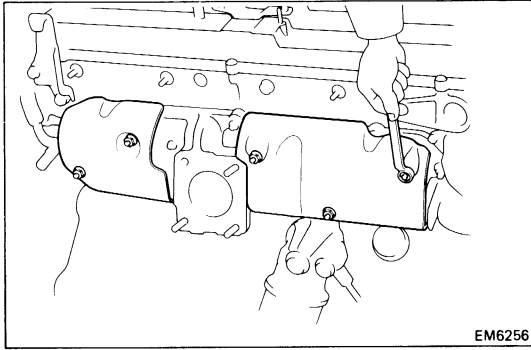

- (b) (7M-GTE)
Remove the three bolts and exhaust manifold stay.

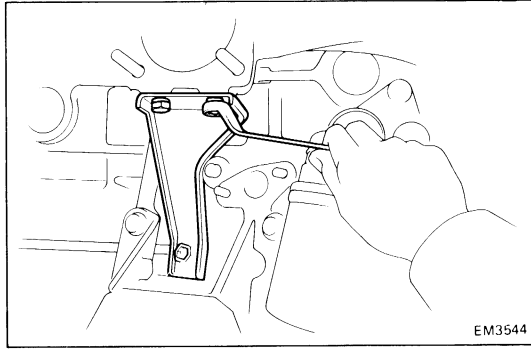

- (c) Remove the seven nuts, exhaust manifold and gasket.

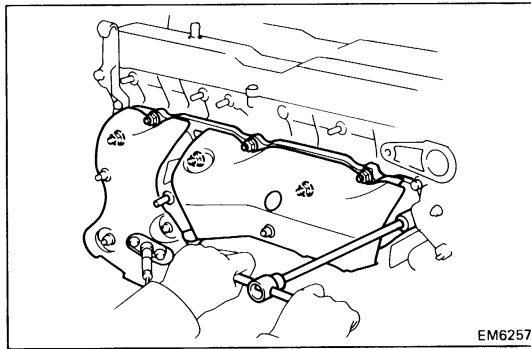
**14. REMOVE WATER OUTLET HOUSING**

- (a) (7M-GE)
Remove the union bolts, union with No.4 water by-pass hose and gaskets.
- (b) Disconnect the No.6 water by-pass hose from the water by-pass pipe.

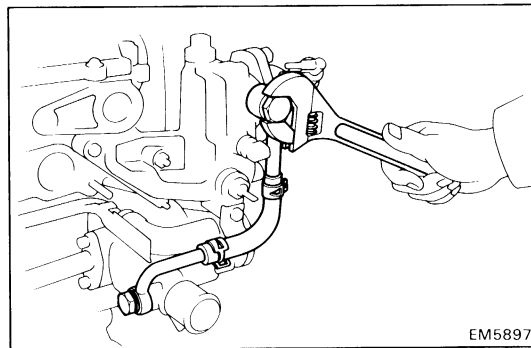

- (c) Remove the bolt, two nuts, water outlet housing and gasket.

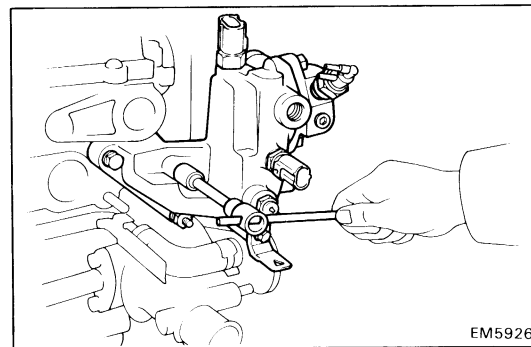

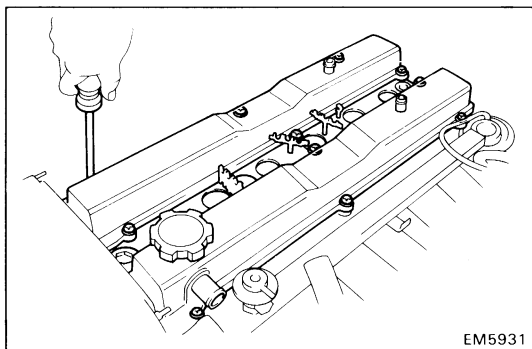
**15. REMOVE CYLINDER HEAD COVERS**

- (a) Remove the accelerator link.
- (b) Remove the heater hose clamp.
- (c) Remove the No. 1 and No. 2 cylinder head covers.

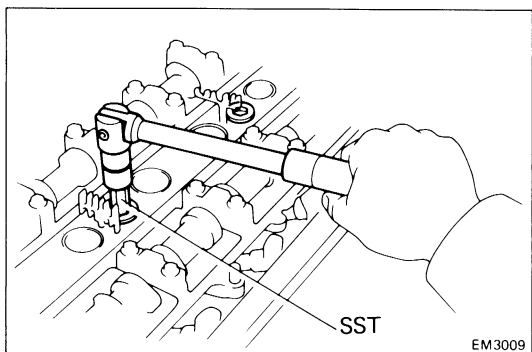

- (d) Using SST, remove the No.3 cylinder head cover.
SST 09923-00010

16. REMOVE SPARK PLUGS**17. REMOVE TIMING BELT AND CAMSHAFT TIMING PULLEYS**

(See steps 5 and 8 to 10 on pages EM-23, 24)

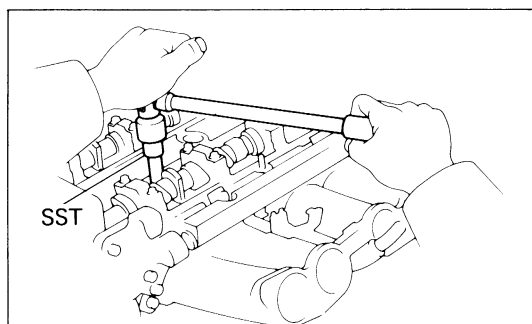
**18. REMOVE CYLINDER HEAD**

- (a) Using SST, remove the head bolts gradually in three passes and in the numerical order shown.

SST 09043-38100

NOTICE: Head warpage or cracking could result from removing bolts in incorrect order.

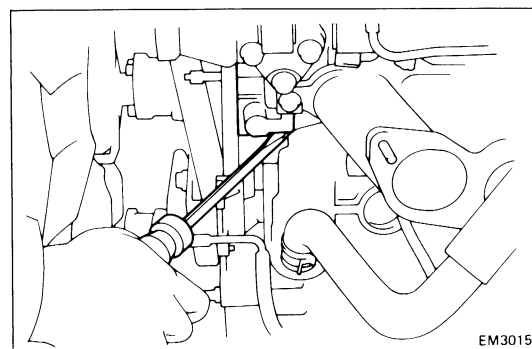
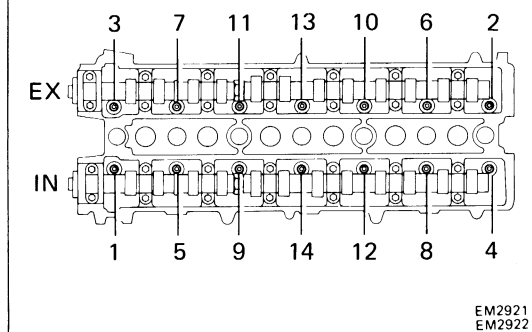

- (b) Lift the cylinder head from the dowels on the cylinder block. As the cylinder head is lifted, separate the No.5 water by-pass hose from the union.

- (c) Place the head on wooden blocks on a bench.

If the cylinder head is difficult to lift off, pry with a screwdriver between the cylinder head and block projection.

NOTICE:

- Be careful not to damage the cylinder head and block surface of the cylinder head gasket.
- Be careful not to damage the VSV.

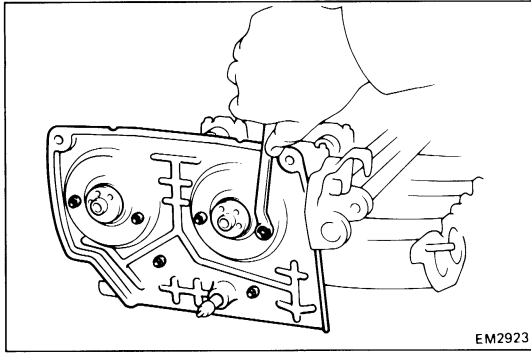

EM2923

DISASSEMBLY OF CYLINDER HEAD

(See pages EM-32, 33)

1. REMOVE NO.2 TIMING BELT COVER
2. REMOVE ALTERNATOR BRACKET
3. REMOVE HEATER INLET HOSE

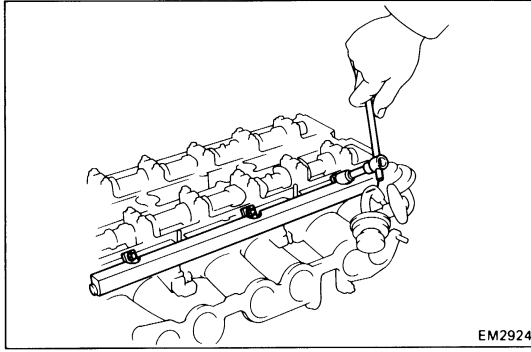

EM2924

4. REMOVE DELIVERY PIPE WITH INJECTORS

- (a) Remove the three bolts, and then remove the delivery pipe with the injectors.

HINT: When removing the delivery pipe, be careful not to drop the injectors.

- (b) Remove the six insulators and three spacers from the cylinder head.

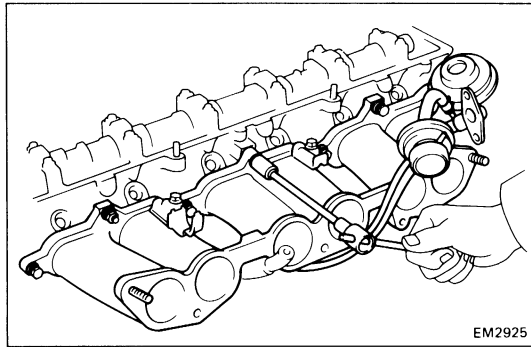

EM2925

5. REMOVE INTAKE MANIFOLD

Remove the four nuts, seven bolts, EGR valve, VSV, intake manifold and gasket.

6. REMOVE NO.2 ENGINE HANGER AND GROUND STRAP

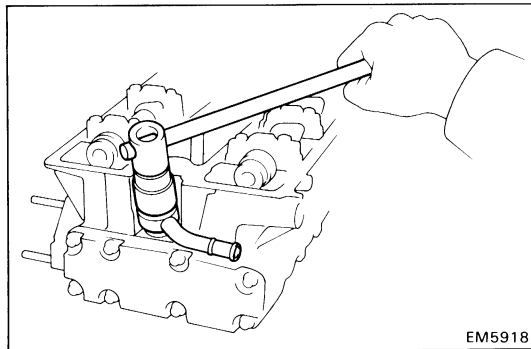

EM5918

7. REMOVE HEATER UNION

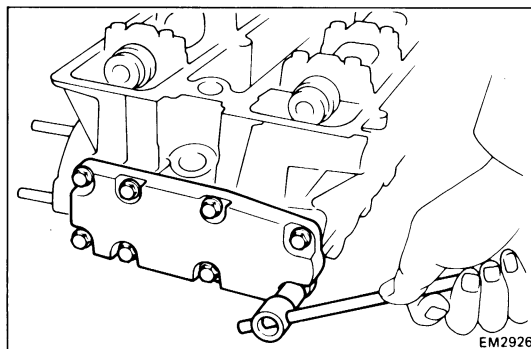

EM2926

8. REMOVE EGR COOLER

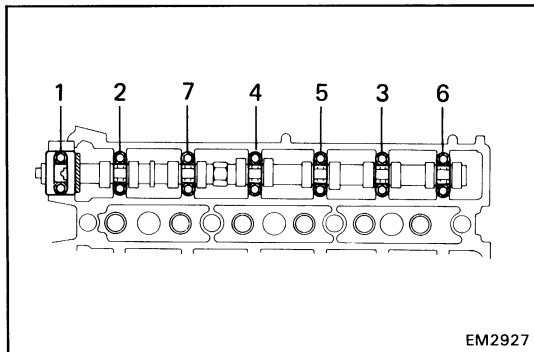

9. REMOVE BEARING CAPS AND CAMSHAFTS

- Loosen each bearing cap bolt a little at a time and in the sequence shown in the figure.
- Remove the camshaft bearing caps, oil seal and camshaft.

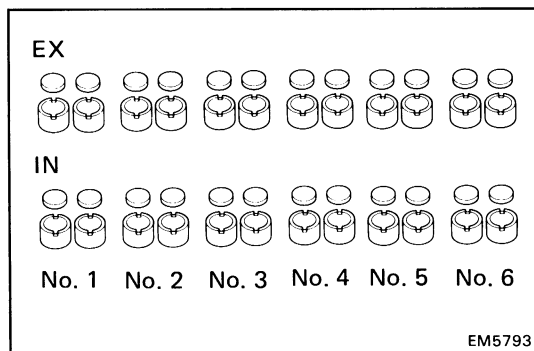

10. REMOVE VALVE LIFTERS WITH SHIMS

HINT: Arrange the valve lifters and shims in order.

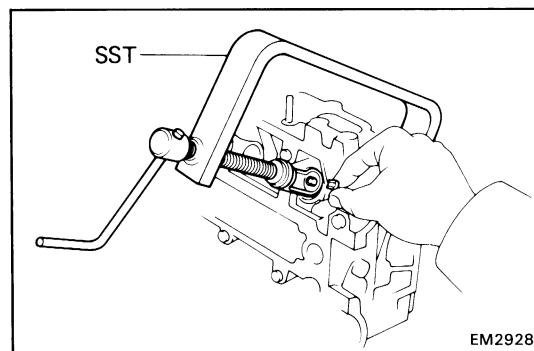

11. REMOVE VALVES

- Using SST, press the valve spring and remove the two keepers.

SST 09202-70010

- Remove the spring retainer, valve spring, seat and valve.
- Pry out the oil seal.

HINT: Arrange the valves, spring seats, valve springs and retainers in correct order.

INSPECTION, CLEANING AND REPAIR OF CYLINDER HEAD COMPONENTS

1. CLEAN TOP OF PISTONS AND TOP OF CYLINDER BLOCK

- Turn the crankshaft and bring each piston to top dead center. Using a gasket scraper, remove all the carbon from the piston tops.
- Using a gasket scraper, remove all gasket material from the top of the block. Blow carbon and oil from the bolt holes.

CAUTION: Protect your eyes when using compressed air.

2. REMOVE GASKET MATERIAL

Using a gasket scraper, remove all gasket material from the head and manifold surfaces.

NOTICE: Be careful not to scratch the surfaces.

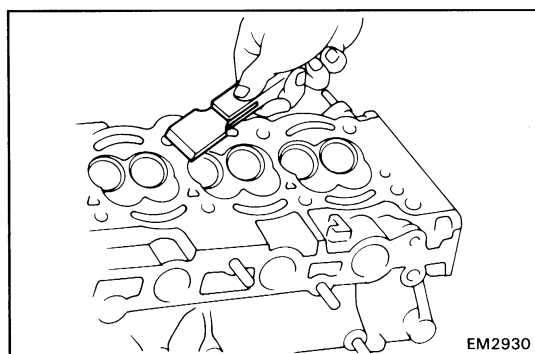
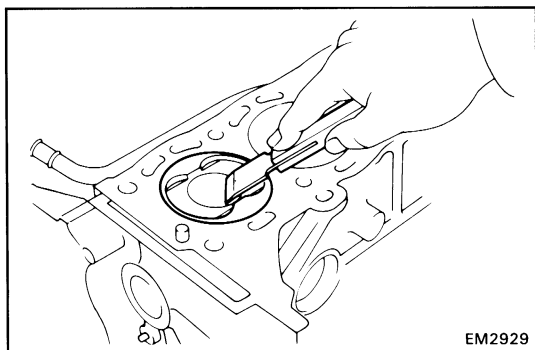

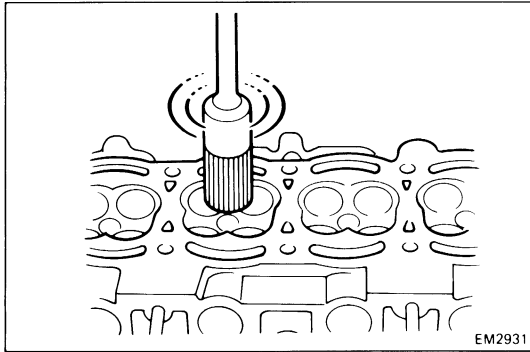

3. CLEAN COMBUSTION CHAMBER

Using a wire brush, remove all the carbon from the combustion chambers.

NOTICE: Be careful not to scratch the head gasket contact surface.

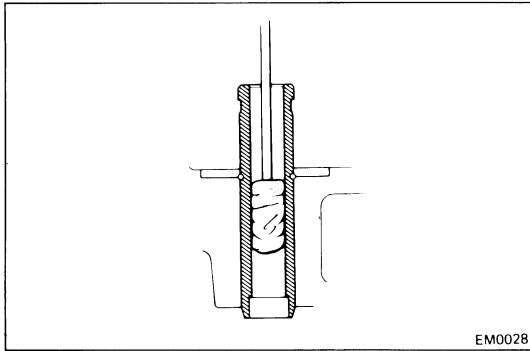

4. CLEAN VALVE GUIDE BUSHINGS

Using a valve guide brush and solvent, clean all the valve guide bushings.

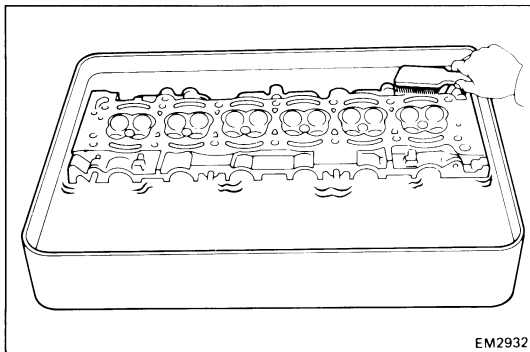

5. CLEAN CYLINDER HEAD

Using a soft brush and solvent, thoroughly clean the head.

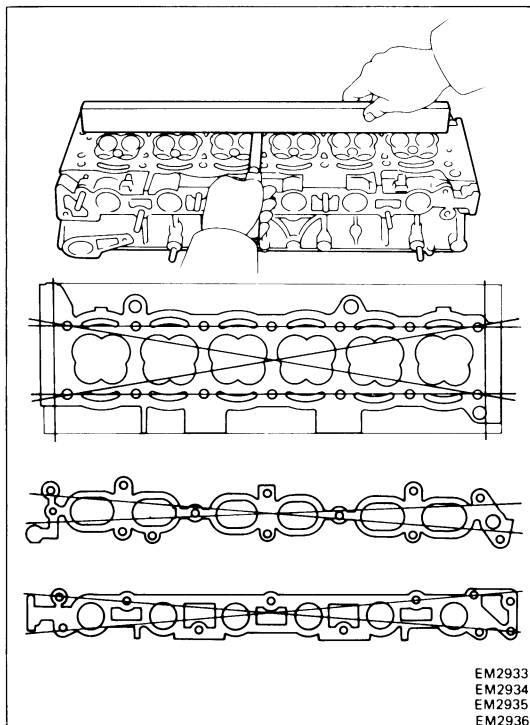

6. INSPECT CYLINDER HEAD FOR FLATNESS

Using a precision straight edge and thickness gauge, measure the surface contacting the cylinder block and manifold for warpage.

Maximum warpage: 0.10 mm (0.0039 in.)

If warpage is greater than maximum, replace the cylinder head.

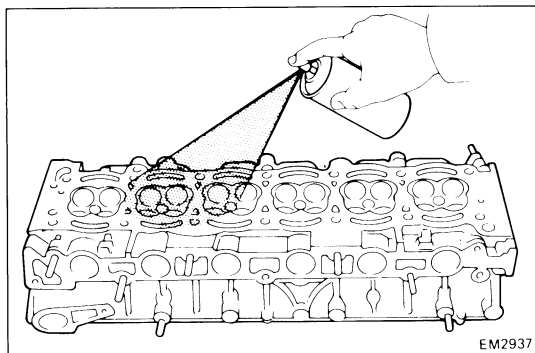

7. INSPECT CYLINDER HEAD FOR CRACKS

Using a dye penetrant, check the combustion chamber, intake and exhaust ports, head surface and the top of the head for cracks.

If cracked, replace the head.

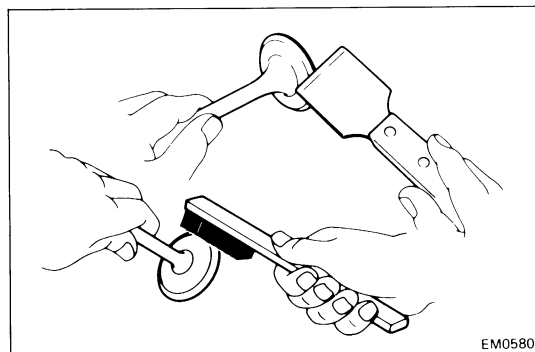

8. CLEAN VALVES

(a) Using a gasket scraper, chip any carbon from the valve head.

(b) Using a wire brush, thoroughly clean the valve.

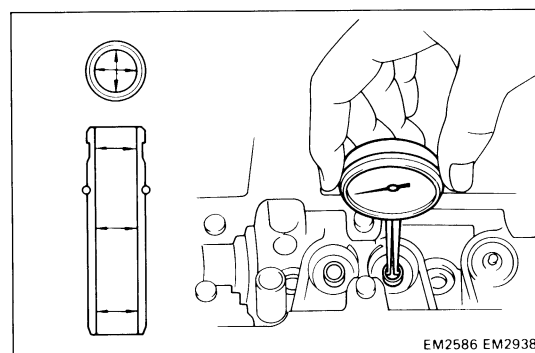

9. INSPECT VALVE STEMS AND GUIDE BUSHINGS

(a) Using a caliper gauge, measure the inside diameter of the valve guide bushing.

Guide inside diameter: 6.010 – 6.030 mm
(0.2366 – 0.2374 in.)

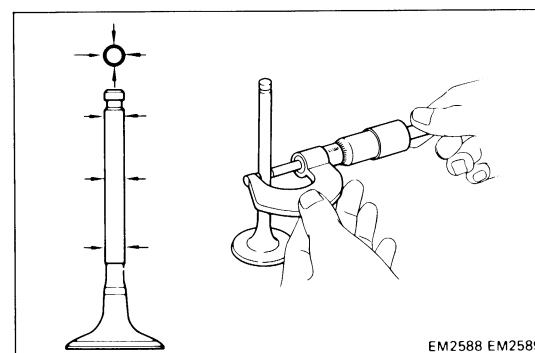

(b) Using a micrometer, measure the diameter of the valve stem.

Stem diameter:

Intake 5.970 – 5.985 mm
(0.2350 – 0.2356 in.)

Exhaust 5.965 – 5.980 mm
(0.2348 – 0.2354 in.)

(c) Subtract the valve stem diameter measurement from the valve guide bushing inside diameter measurement.

Standard stem oil clearance:

Intake 0.025 – 0.060 mm
(0.0010 – 0.0024 in.)

Exhaust 0.030 – 0.065 mm
(0.0012 – 0.0026 in.)

Maximum stem oil clearance:

Intake 0.08 mm (0.0031 in.)

Exhaust 0.10 mm (0.0039 in.)

If the clearance is greater than maximum, replace the valve and guide bushing.

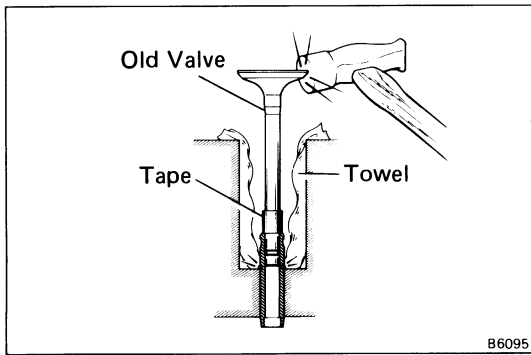

10. IF NECESSARY, REPLACE VALVE GUIDE BUSHINGS

- (a) Insert an old valve wrapped with tape into the valve guide bushing and break off the valve guide bushing by hitting it with a hammer.

NOTICE: Be careful not to damage the lifter hole.

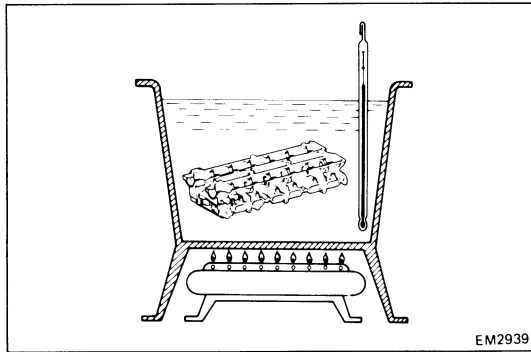

- (b) Gradually heat the cylinder head to approx. 90°C (194°F).

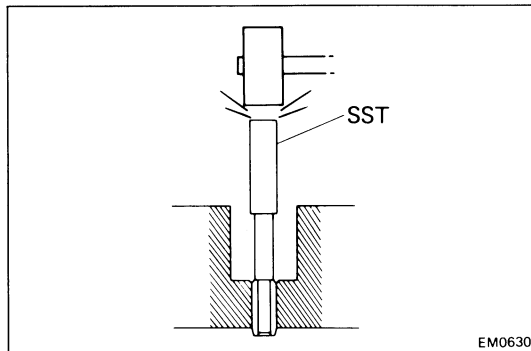

- (c) Using SST and hammer, drive out valve guide bushing.
SST 09201-70010

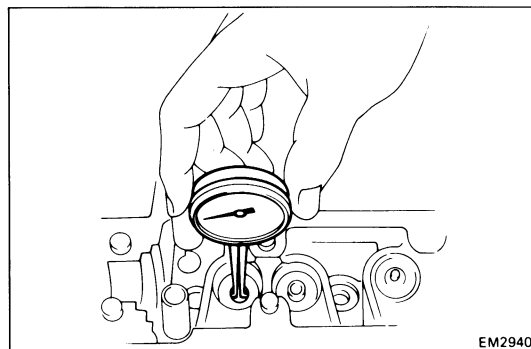

- (d) Using a caliper gauge, measure the valve guide bore of the cylinder head.

- (e) Select a new valve guide bushing.

If the valve guide bushing bore of the cylinder head is more than 11.027 mm (0.4341 in.), machine the bore to the following dimensions.

Rebored valve guide bushing bore dimension:

11.050 — 11.077 mm (0.4350 — 0.4361 in.)

Both intake and exhaust

| Bushing bore mm (in.) | Bushing size |
|--------------------------------------|--------------|
| 11.000 — 11.027 (0.4331 — 0.4341) | Use STD |
| Over 11.027 (0.4341) | Use O/S 0.05 |

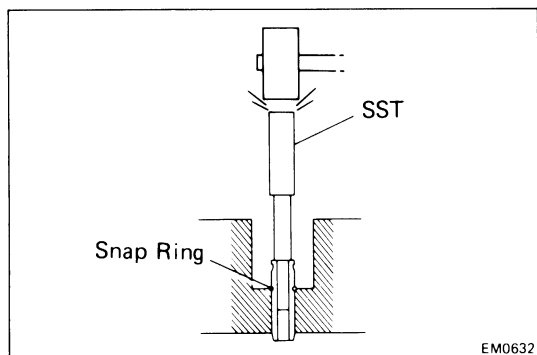

- (f) Gradually heat the cylinder head to approx. 90°C (194°F).
- (g) Using SST and hammer, drive in a new valve guide bushing until the snap ring makes contact with the cylinder head.

SST 09201-70010

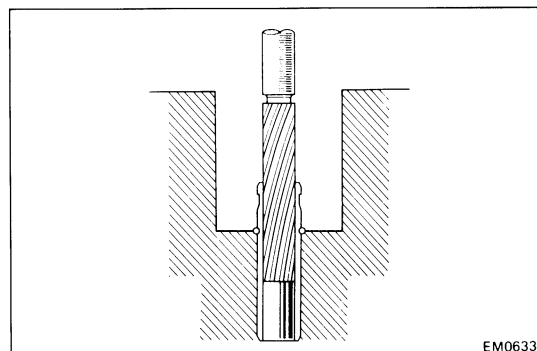

- (h) Using a sharp 6 mm (0.24 in.) reamer, ream the valve guide bushing to obtain standard specified clearance (See page EM-43) between the valve guide bushing and new valve.

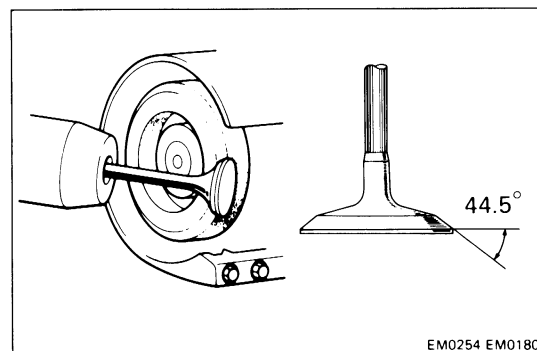

11. INSPECT AND GRIND VALVES

- (a) Grind the valve only enough to remove pits and carbon.
- (b) Check that the valve is ground to the correct valve face angle.

Valve face angle: 44.5°

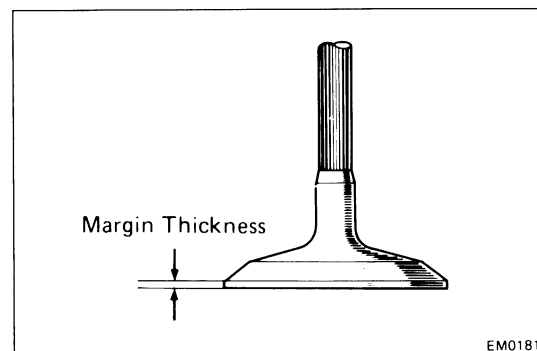

- (c) Check the valve head margin thickness.

Standard margin thickness: 1.3 mm (0.051 in.)

Minimum margin thickness: 0.5 mm (0.020 in.)

If the valve head margin thickness is less than minimum, replace the valve.

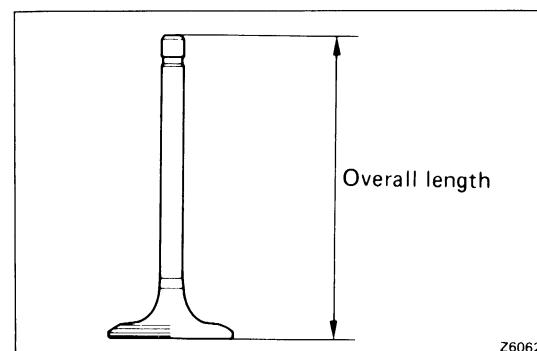

- (d) Check the valve overall length.

Standard overall length: 98.15 mm (3.8642 in.)

Minimum overall length: 97.75 mm (3.8484 in.)

If the valve overall length is less than minimum, replace the valve.

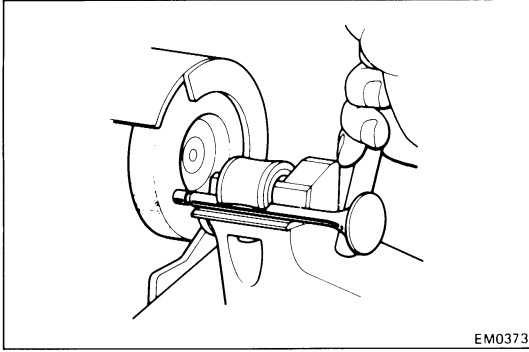

(e) Check the surface of the valve stem tip for wear. If the valve stem tip is worn, regrind it with grinder or replace the valve if necessary.

NOTICE: Do not grind off more than minimum overall length (See page EM-45).

12. INSPECT AND CLEAN VALVE SEATS

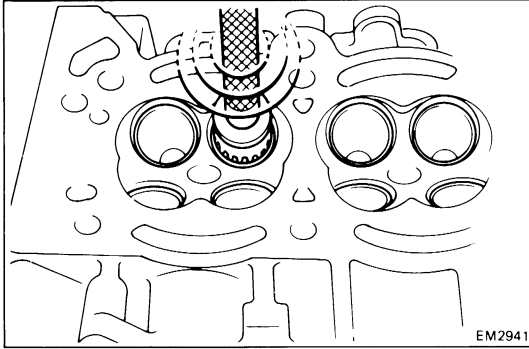

(a) Using a 45° cutter, resurface the valve seats. Remove only enough metal to clean the seats.

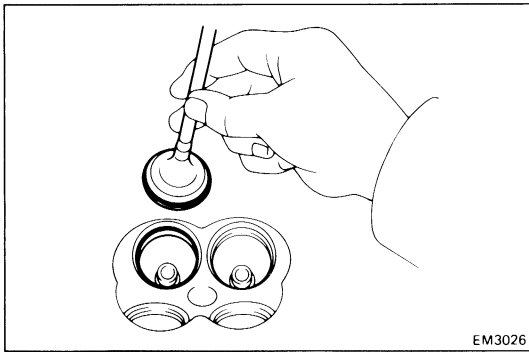

(b) Check the valve seating position.

Apply a thin coat of prussian blue (or white lead) to the valve face. Install the valve. Lightly press the valve against the seat. Do not rotate the valve.

- (c) Check the valve face and seat for the following:
- If blue appears 360° around the face, the valve is concentric. If not, replace the valve.
 - If blue appears 360° around the valve seat, the guide and seat are concentric. If not, resurface the seat.
 - Check that the seat contact is on the middle of the valve face with the following width:
1.0 – 1.4 mm (0.039 – 0.055 in.)

If not, correct the valve seat as follows:

- If seating is too high on the valve face use 30° and 45° cutters to correct the seat.
- If seating is too low on the valve face, use 60° and 45° cutters to correct the seat.

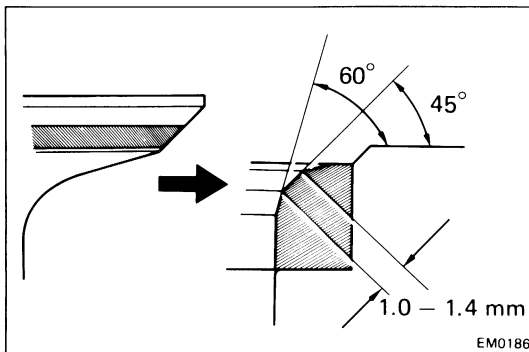
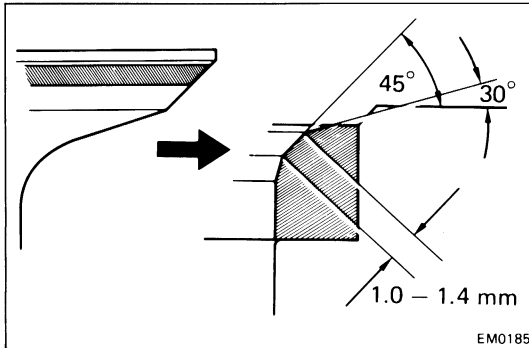

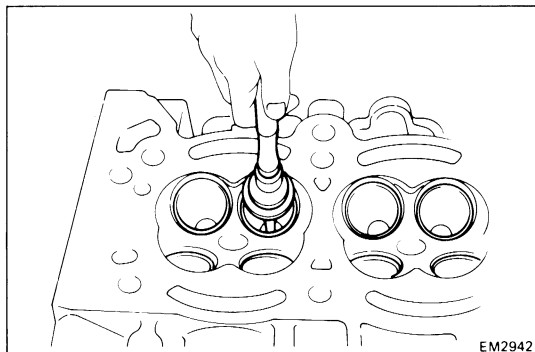

- (d) Hand-lap the valve and valve seat with an abrasive compound.

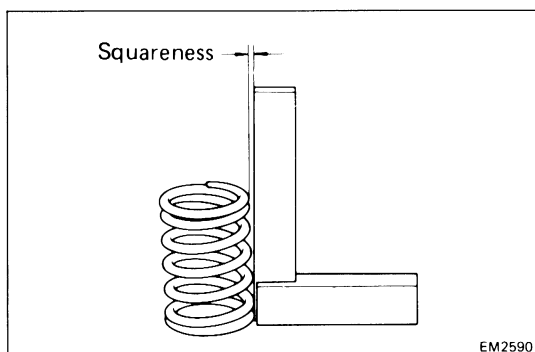

13. INSPECT VALVE SPRINGS

- (a) Using a steel square, measure the squareness of the valve springs.

Maximum squareness: 1.5 mm (0.059 in.)

If squareness is greater than maximum, replace the valve spring.

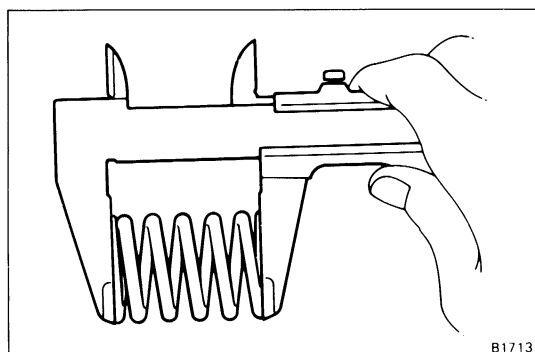

- (b) Using calipers, measure the free length of the valve spring.

Free length: 41.64 mm (1.6394 in.)

If the free length is not within specification, replace the valve spring.

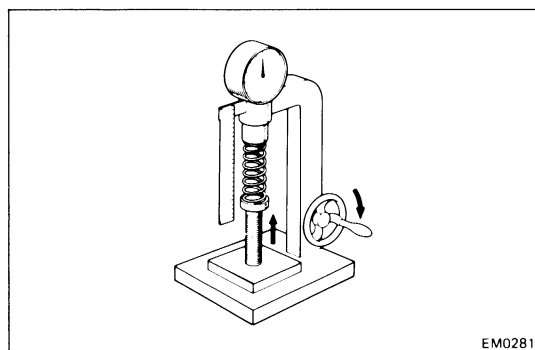

- (c) Using a spring tester, measure the tension of the valve spring at the specified installed length.

Installed tension:

16.0 kg (35 lb, 157 N) at 35.0 mm (1.378 in.)

If the installed tension is not as specified, replace the valve spring.

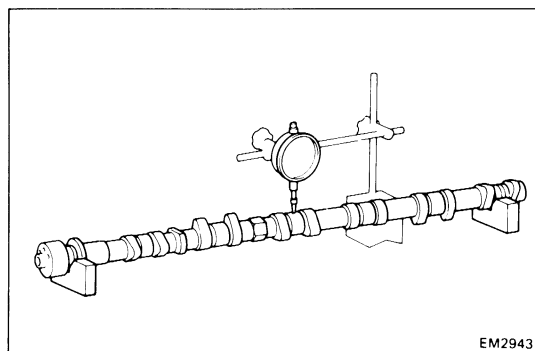

14. INSPECT CAMSHAFT AND BEARING CAPS

- (a) Place the camshaft on V-blocks and, using a dial gauge, measure the circle runout at the center journal.

Maximum circle runout: 0.03 mm (0.0012 in.)

If the circle runout is greater than maximum, replace the camshaft.

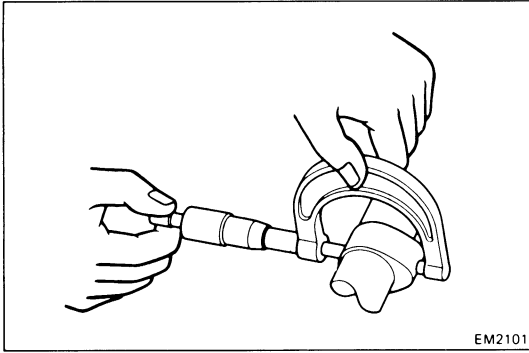

(b) Using a micrometer, measure the cam lobe height.

Standard cam lobe height:

| | | |
|---------|--------|-----------------------|
| Intake | 7M-GE | 38.16 mm (1.5024 in.) |
| | 7M-GTE | 38.35 mm (1.5098 in.) |
| Exhaust | | 38.35 mm (1.5098 in.) |

Minimum cam lobe height:

| | | |
|---------|--------|-----------------------|
| Intake | 7M-GE | 37.85 mm (1.4902 in.) |
| | 7M-GTE | 38.00 mm (1.4961 in.) |
| Exhaust | | 38.00 mm (1.4961 in.) |

If the cam lobe height is less than minimum, replace the camshaft.

(c) Using a micrometer, measure the journal diameter.

Standard diameter:

| | |
|----------------------|--|
| No.1 journal | 26.949 – 26.965 mm (1.0610 – 1.0616 in.) |
| No.2 – No.7 journals | 26.888 – 26.975 mm (1.0586 – 1.0620 in.) |

If the journal diameter is less than specified, replace the camshaft.

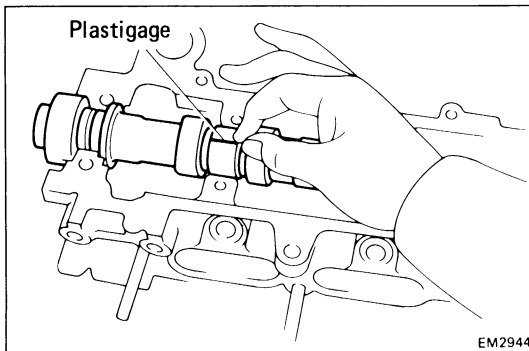
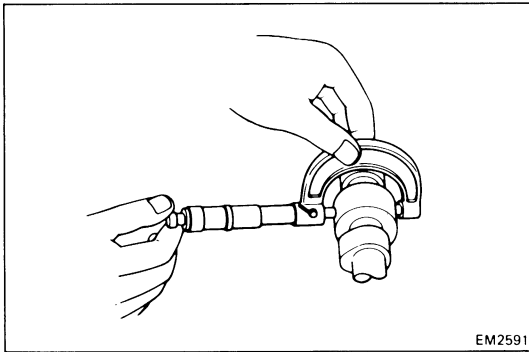

15. INSPECT CAMSHAFT OIL CLEARANCE

- Clean the bearing caps and camshaft journal.
- Place the camshaft in the cylinder head.
- Lay a strip of Plastigage across each journal.

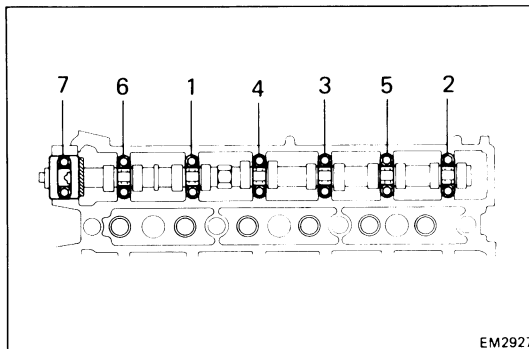

- Place the bearing caps with the top of the number on the cap pointing toward the front and in numerical order from the front side.
- Install and torque the cap bolts gradually in the sequence shown in the figure.

Torque: 200 kg-cm (14 ft-lb, 20 N·m)

HINT: Do not turn the camshaft while the Plastigage is in place.

- Remove the caps and measure the Plastigage at its widest point.

Standard oil clearance:

| | |
|----------------------|--|
| No.1 journal | 0.035 – 0.072 mm (0.0014 – 0.0028 in.) |
| No.2 – No.7 journals | 0.025 – 0.093 mm (0.0010 – 0.0037 in.) |

Maximum oil clearance: 0.13 mm (0.0051 in.)

If clearance is greater than maximum, replace the cylinder head and/or camshaft.

- Clean out the pieces of Plastigage from the bearing caps and journals.

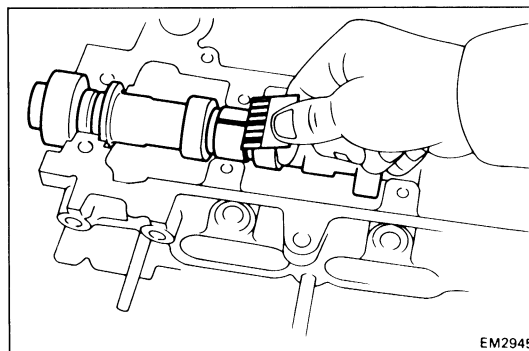

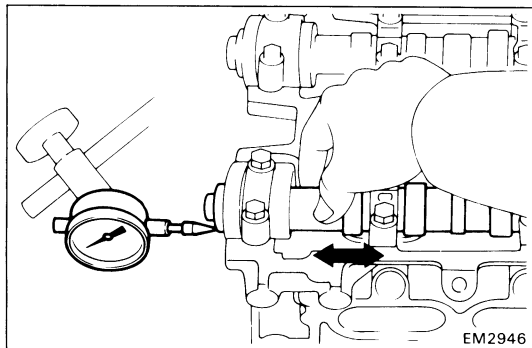
**16. INSPECT CAMSHAFT THRUST CLEARANCE**

- (a) Clean and install the camshaft and bearing caps.
- (b) Using a dial gauge, measure the thrust clearance while moving the camshaft back and forth.

Standard thrust clearance: 0.08 — 0.19 mm
(0.0031 — 0.0075 in.)

Maximum thrust clearance: 0.30 mm (0.0118 in.)

If clearance is greater than maximum, replace the camshaft and/or cylinder head.

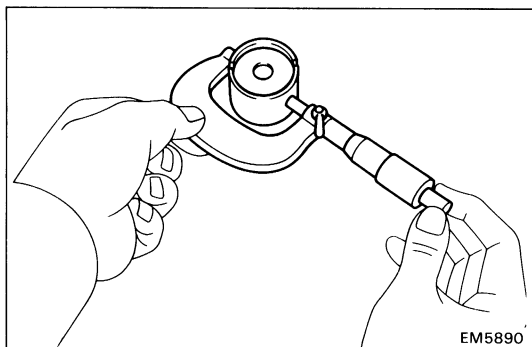
**17. INSPECT VALVE LIFTER OIL CLEARANCE**

- (a) Using a micrometer, measure the diameter of the valve lifter.

Valve lifter diameter: 27.975 — 27.985 mm
(1.1014 — 1.1018 in.)

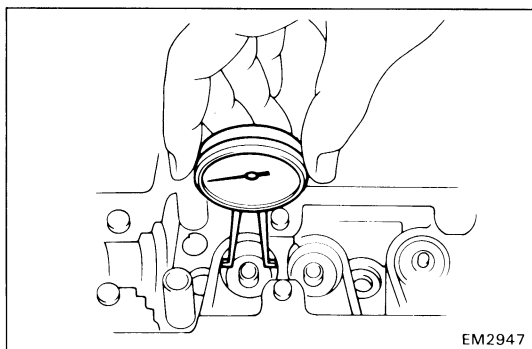

- (b) Using a dial indicator, measure the inside diameter of the cylinder head bore.

Lifter bore diameter: 28.000 — 28.021 mm
(1.1024 — 1.1032 in.)

- (c) Subtract the valve lifter measurement from the cylinder head bore.

Standard oil clearance: 0.015 — 0.046 mm
(0.0006 — 0.0018 in.)

Maximum oil clearance: 0.10 mm (0.0039 in.)

If clearance is greater than maximum, replace the cylinder head and/or valve lifter.

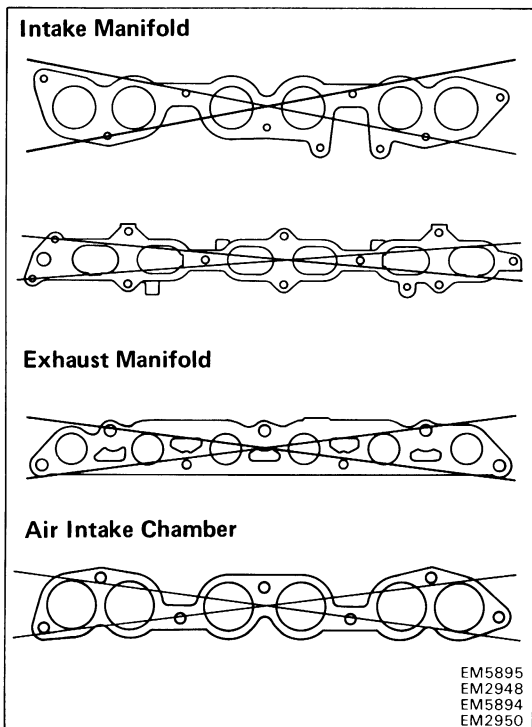
**18. INSPECT INTAKE, EXHAUST MANIFOLDS AND AIR INTAKE CHAMBER**

Using a precision straight edge and thickness gauge, check the surfaces contacting the cylinder head or intake manifold for warpage.

Maximum warpage:

| | | |
|------------------|--------|---------------------|
| Intake manifold | | 0.10 mm (0.0039in.) |
| Exhaust manifold | 7M-GE | 0.75 mm (0.0295in.) |
| | 7M-GTE | 0.50 mm (0.0197in.) |
| Intake chamber | | 0.10 mm (0.0039in.) |

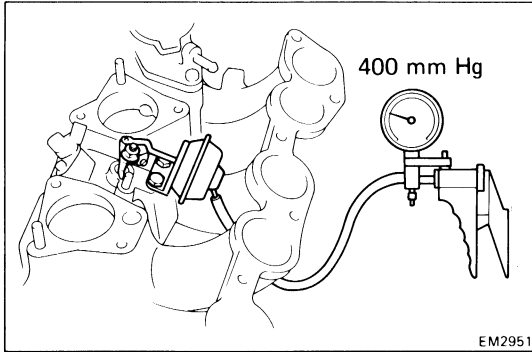

INSPECTION OF INTAKE AIR CONTROL SYSTEM (7M-GE only)

1. CHECK AIR CONTROL VALVE OPERATION

With 400 mmHg (15.75 in.Hg, 53.3 kPa) of vacuum applied to the actuator, check that the control valve moves smoothly to the fully closed position.

If not, adjust with the adjusting screw.

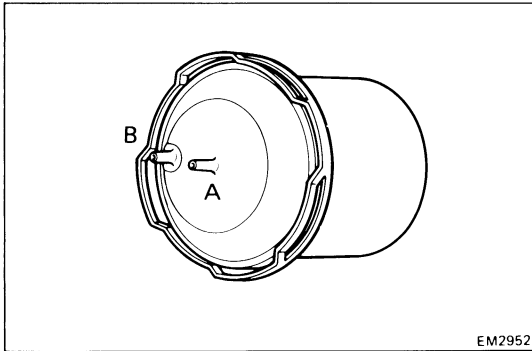

2. CHECK VACUUM TANK BY BLOWING AIR INTO EACH PIPE

(a) Check that air flows from pipe B to A.

(b) Check that air does not flow from pipe A to B.

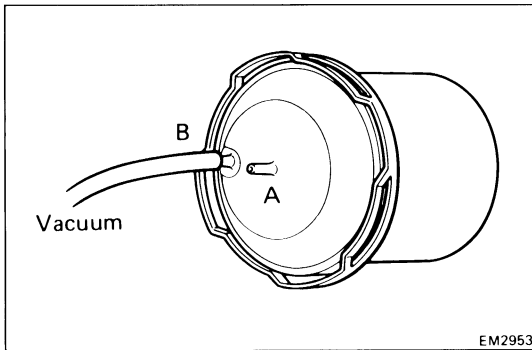

(c) Apply 500 mmHg (19.69 in.Hg, 66.7 kPa) of vacuum to pipe B and check that there is no change in vacuum after one minute.

If there is a change, replace the vacuum tank.

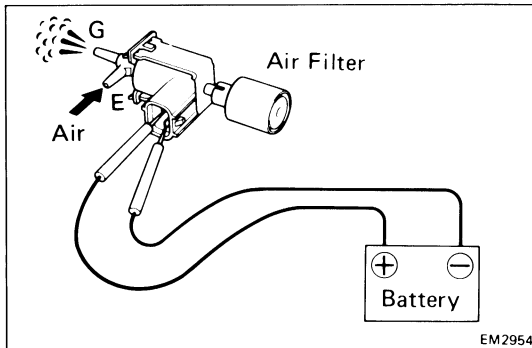

3. CHECK VACUUM CIRCUIT CONTINUITY IN THE VSV BY BLOWING AIR INTO PIPE

(a) Connect the VSV terminals to the battery terminals as illustrated.

(b) Blow air into pipe E and check that air comes out of pipe G.

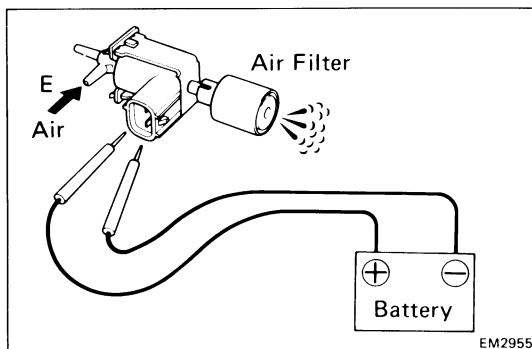

(c) Disconnect the battery.

(d) Blow air into pipe E and check that air comes out of the air filter.

If a problem is found, replace the VSV.

ASSEMBLY OF CYLINDER HEAD

(See pages EM-32, 43)

HINT:

- Thoroughly clean all parts to be assembled.
- Before installing the parts, apply new engine oil to all sliding and rotating surfaces.
- Replace all gaskets and oil seals with new ones.

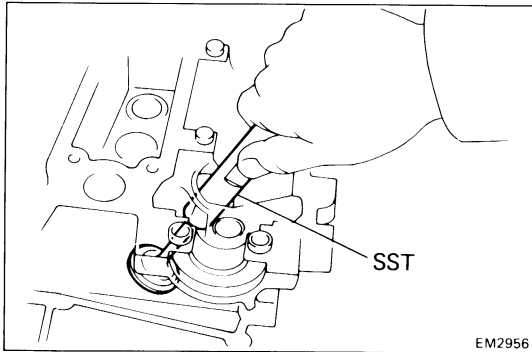
**1. INSTALL VALVES**

- Insert the valves in the cylinder head valve guide bushing. Make sure the valves are installed in correct order.
- Using SST, install new oil seals on the valve guide bushings.

SST 09201-41020

- Install spring seats, springs and spring retainers.

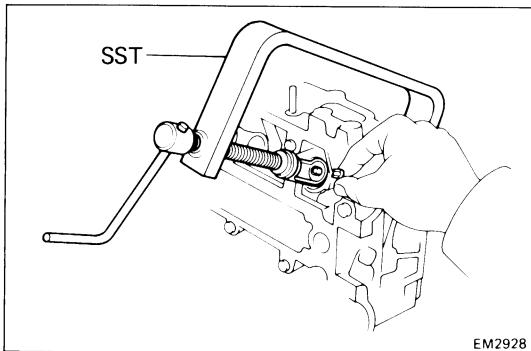

- Using SST, compress the valve retainers and place two keepers around the valve stem.

SST 09202-70010

- Tap the stem lightly to assure proper fit.

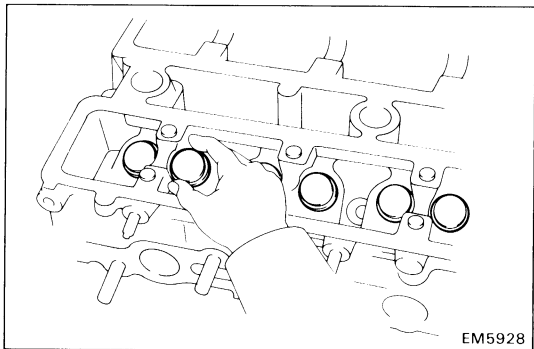
**2. INSTALL VALVE LIFTERS WITH SHIMS**

Check that the valve lifters rotate smoothly by hand.

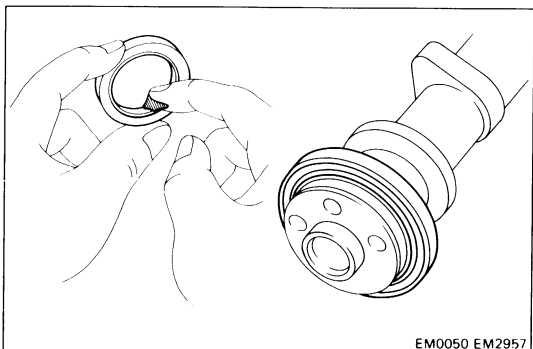
**3. INSTALL CAMSHAFTS AND OIL SEALS**

- Apply engine oil to the lip of a new oil seal.
- Install the oil seal to the camshaft.

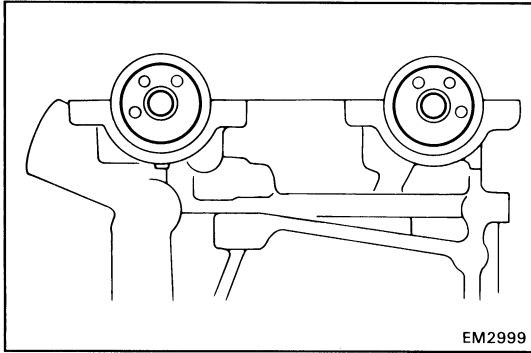

- (c) Coat all bearing journals with engine oil.
- (d) Place the camshafts on the cylinder head as shown in the illustration.

HINT: The exhaust camshaft has a distributor (7M-GE) or cam position sensor (7M-GTE) drive gear.

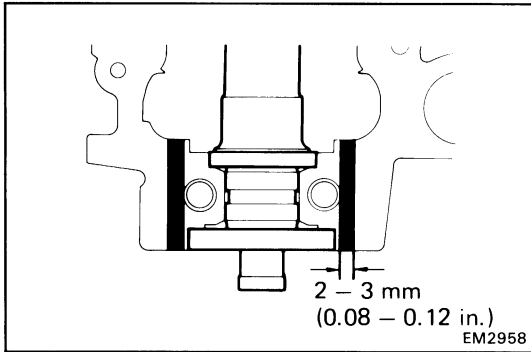

- (e) Apply seal packing to the areas indicated in the illustration.

Seal packing: Part No.08826-00080 or equivalent

HINT: Install the No.1 bearing cap immediately after applying the seal packing.

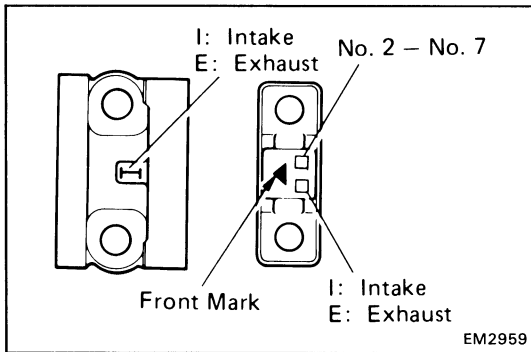

- (f) Place bearing caps on each journal with the front marks pointing toward the front and in numerical order from the front side.

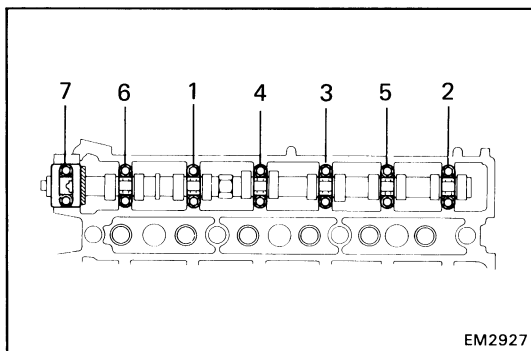

- (g) Temporarily install the bearing cap bolts in the several passes in the sequence shown.

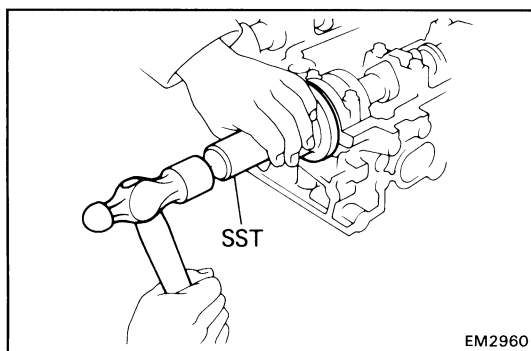

- (h) Using SST, tap in the camshaft oil seal.

SST 09223-50010

HINT: Be careful not to install the oil seal slantwise.

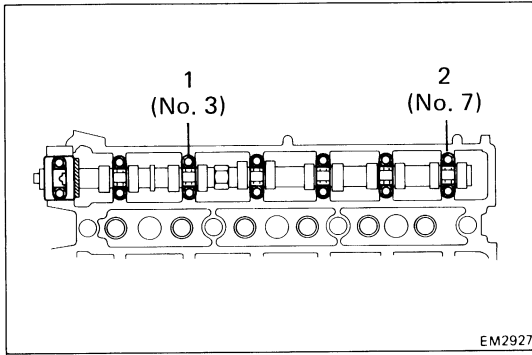

- (i) Uniformly tighten the No.3 and No.7 bearing cap bolts in several passes, in the sequence shown.

Torque: 200 kg-cm (14 ft-lb, 20 N·m)

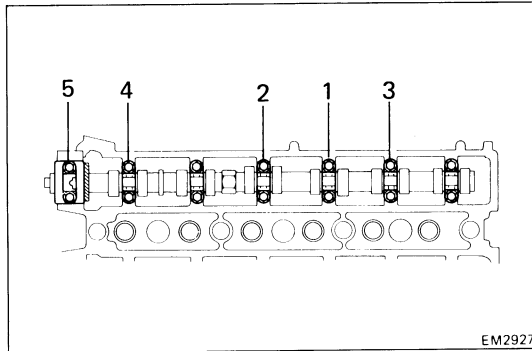

- (j) Uniformly tighten other bearing cap bolts in several passes, in the sequence shown.

Torque: 200 kg-cm (14 ft-lb, 20 N·m)

- (k) Check the camshaft thrust clearance.

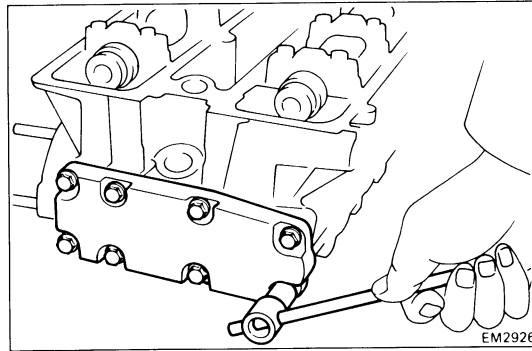

4. INSTALL EGR COOLER

Install a new gasket and EGR cooler with the eight bolts.

Torque: 140 kg-cm (10 ft-lb, 14 N·m)

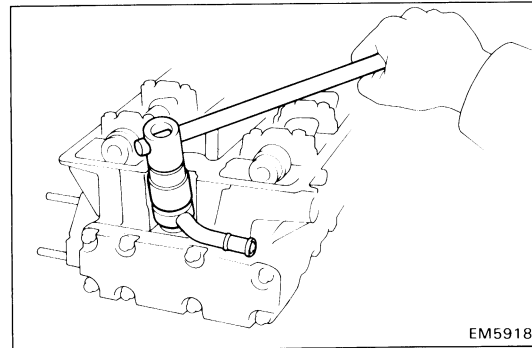

5. INSTALL HEATER UNION

Install a new gasket, union, another gasket and union bolt to the cylinder head. Torque the union bolt.

Torque: 600kg-cm (43 ft-lb, 59 N·m)

6. INSTALL NO.2 ENGINE HANGER AND GROUND STRAP

Torque: 400 kg-cm (29 ft-lb, 39 N·m)

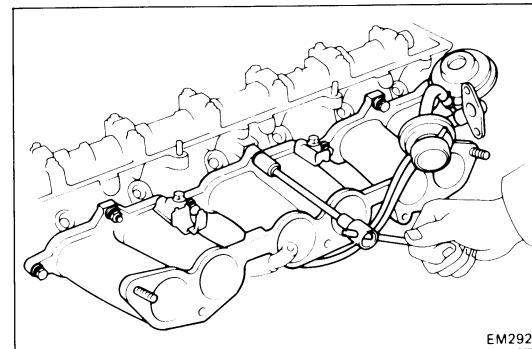

7. INSTALL INTAKE MANIFOLD

- (a) Position a new gasket on the cylinder head.

- (b) Install the intake manifold and VSV with the two nuts and seven bolts.

- (c) Install the EGR valve with the two nuts.

- (d) Torque the bolts and nuts.

Torque: 180 kg-cm (13 ft-lb, 18 N·m)

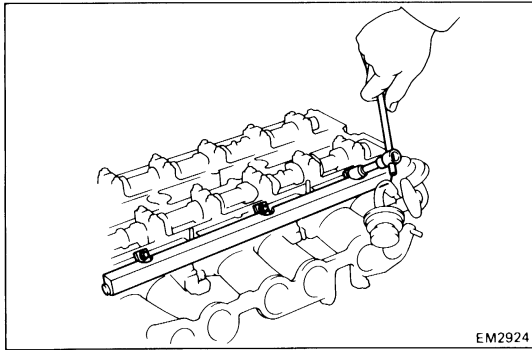
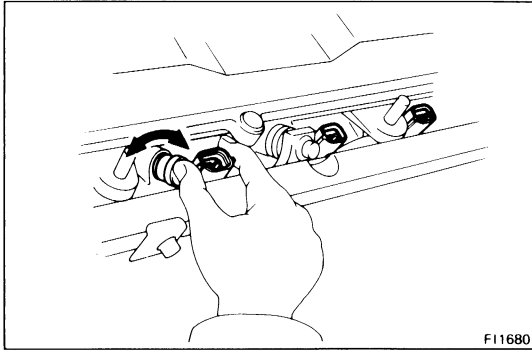
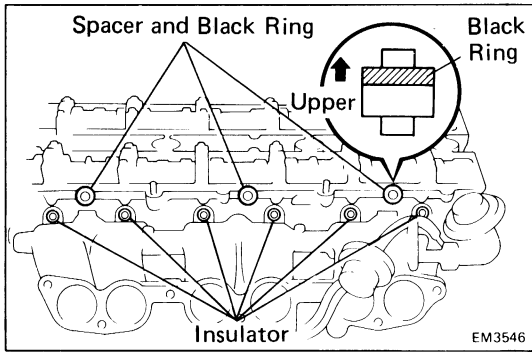

8. INSTALL DELIVERY PIPE WITH INJECTORS

- (a) Install the six insulators into the injector hole of the cylinder head.
- (b) Install the black rings on the upper portion of each of the three spacers. Then install the spacers on the delivery pipe mounting hole of the cylinder head.

- (c) Place the injectors together with the delivery pipe on the cylinder head.
- (d) Make sure that the injectors rotate smoothly.

- (e) Install the three thinner spacers and bolts. Torque the bolts.

Torque: 180 kg-cm (13 ft-lb, 18 N·m)

9. INSTALL ALTERNATOR BRACKET

Torque: 400 kg-cm (29 ft-lb, 39 N·m)

10. INSTALL NO.2 TIMING BELT COVER

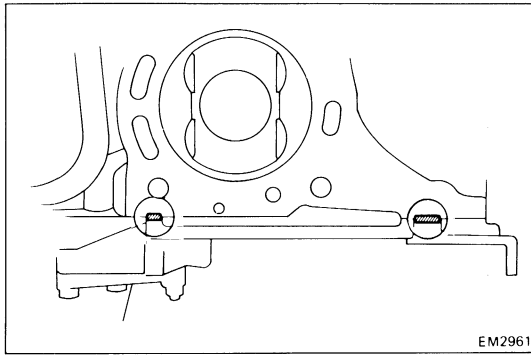

INSTALLATION OF CYLINDER HEAD

(See pages EM-32, 33)

1. INSTALL CYLINDER HEAD

(a) Apply seal packing to the two locations shown.

Seal packing: Part No. 08826-00080 or equivalent

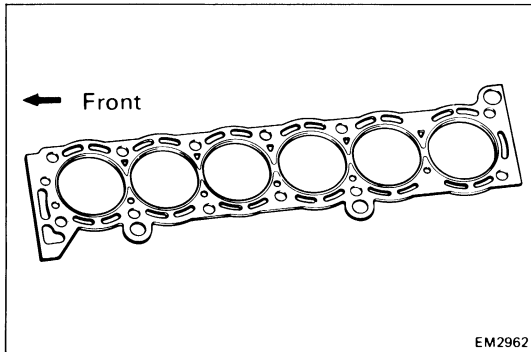

(b) Place a new cylinder head gasket on the cylinder block.

NOTICE: Be careful of the installation direction.

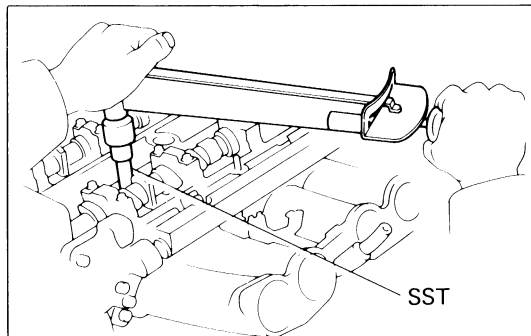

(c) Place the cylinder head on the cylinder head gasket, and connect the No.5 water by-pass hose to the union.

(d) Apply a light coat of the engine oil on the threads and under the cylinder head bolts.

(e) Using SST, install and uniformly tighten the fourteen cylinder head bolts in several passes and in the sequence shown.

SST 09043-38100

Torque: 800 kg-cm (58 ft-lb, 78 N·m)

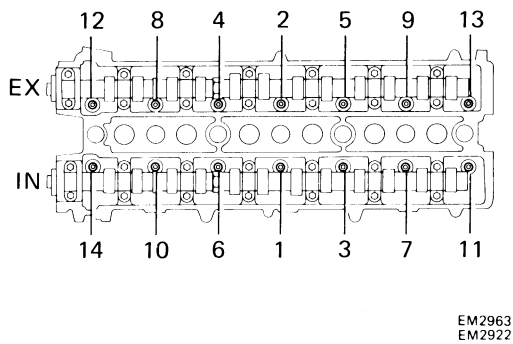

2. INSTALL CAMSHAFT TIMING PULLEYS AND TIMING BELT

(See steps 8 to 11, and 14 on pages EM-29 to 31)

3. INSTALL SPARK PLUGS

4. INSTALL CYLINDER HEAD COVERS

(a) Using SST, install the No.3 cylinder head cover.

SST 09923-00010

Torque: 180 kg-cm (13 ft-lb, 18 N·m)

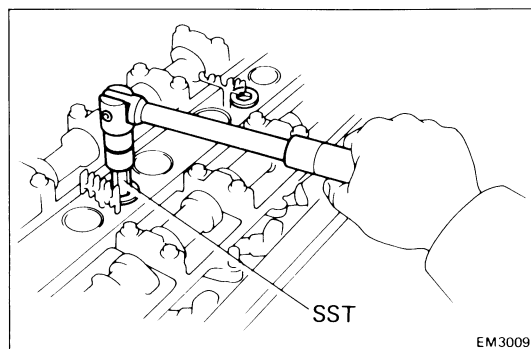

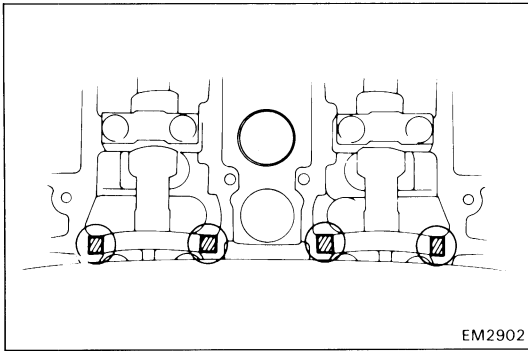

- (b) Apply seal packing to the cylinder head as shown in the illustration.

Seal packing: Part No. 08826-00080 or equivalent

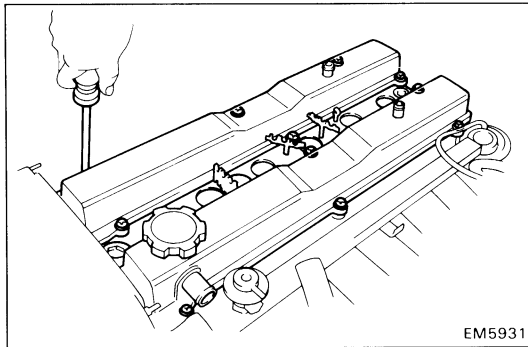

- (c) Install the No.1 and No.2 cylinder head covers.

Torque: 25 kg-cm (22 in.-lb, 2.5 N·m)

- (d) Install the heater hose clamp.
(e) Install the accelerator link.

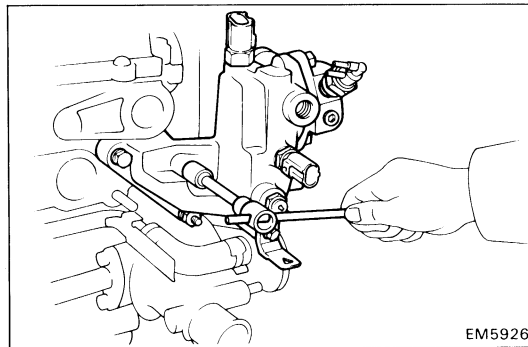

5. INSTALL WATER OUTLET HOUSING

- (a) Install a new gasket and water outlet housing with the bolt and two nuts.
(b) Connect the No.6 water by-pass hose.

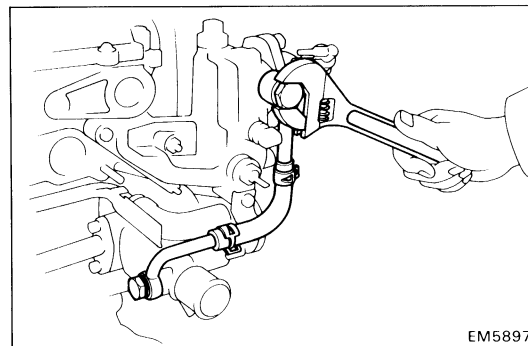

- (c) (7M-GE)
Install unions with No.4 water by-pass hose to the water outlet housing with new gaskets and union bolts.

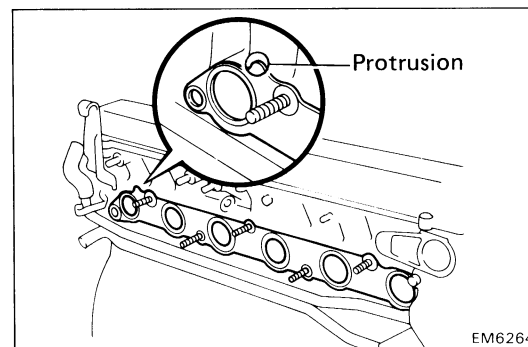

6. INSTALL EXHAUST MANIFOLD

- (a) Face a new exhaust gasket so the protrusion is facing the rear and install on the cylinder head.

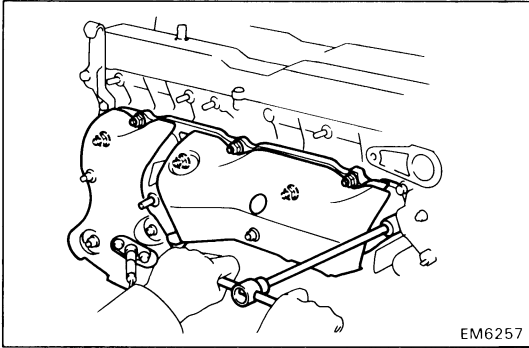

- (b) Install the exhaust manifold with the seven nuts.
Torque: 400 kg-cm (29 ft-lb, 39 N·m)

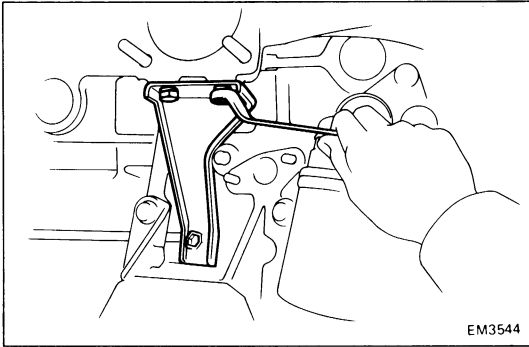

- (c) (7M-GTE)
Install the exhaust manifold stay with the three bolts.

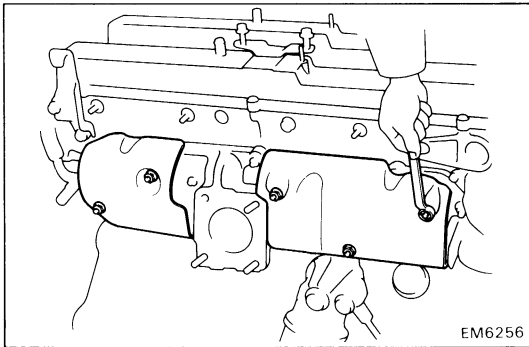

- (d) (7M-GTE)
Install the heat insulators with the five bolts.

7. (7M-GTE)
INSTALL TURBOCHARGER
(See steps 4 to 8 and 10 to 12 on pages TC-15 to 18)
8. (7M-GE)
INSTALL OIL DIPSTICK
9. (7M-GE)
INSTALL DISTRIBUTOR AND HIGH-TENSION CORDS
(See page IG-19)
10. (7M-GTE)
INSTALL AUXILIARY AIR PIPE

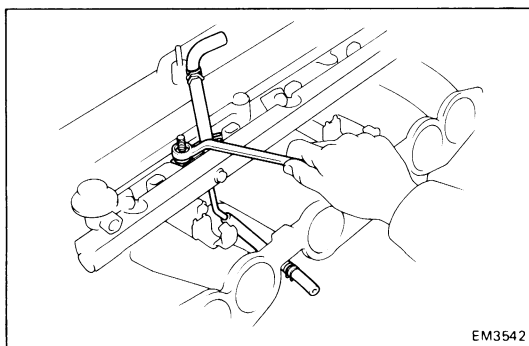

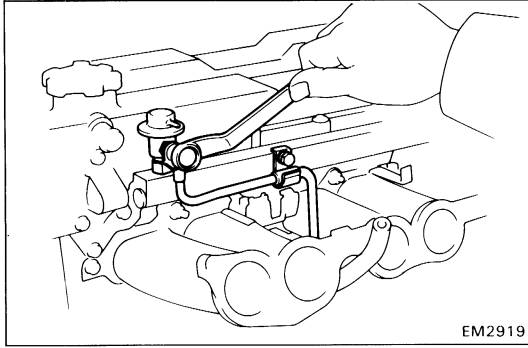
**11. INSTALL NO.2 FUEL PIPE**

- (a) Install a new gasket, No.2 fuel pipe, another gasket and union bolt to the pressure regulator.

Torque: 250 kg-cm (18 ft-lb, 25 N·m)

- (b) Install the No.2 fuel pipe to the delivery pipe with the bolt.
 (c) Connect the fuel hose to fuel return pipe support.

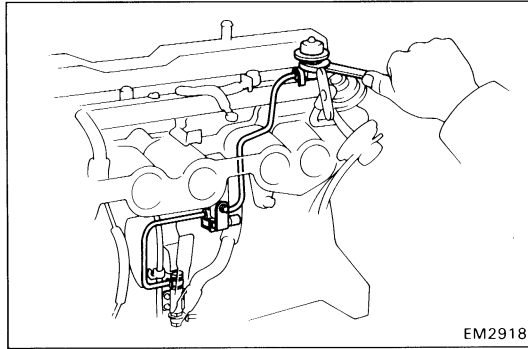
**12. INSTALL NO.1 FUEL PIPE**

- (a) Install the No.1 fuel pipe with VSV with the clamp bolt.
 (b) Connect the pipe to the fuel pipe support with the union bolt and new gaskets. Torque the union bolt.

Torque: 300 kg-cm (22 ft-lb, 29 N·m)

- (c) Connect the pipe to the delivery pipe with the union bolt (7M-GE) or pulsation damper (7M-GTE) and new gaskets. Torque the union bolt or pulsation damper.

Torque: 400 kg-cm (29 ft-lb, 39 N·m)

13. INSTALL ENGINE WIRE

- (a) Install the engine wire to the four clamps.
 (b) Connect the following connectors and wire:

- Transmission connectors
- Starter connector (Terminal 50)
- Main relay connector
- Noise filter connector
- (7M-GE)
Ignition coil connector
- (7M-GTE)
Igniter connectors
- (7M-GTE)
Solenoid resistor connector
- Check connector
- Ground strap to intake manifold
- Knock sensor connector
- Two VSV connectors
- Injector connectors
- (7M-GE)
Distributor connector
- Cold start injector time switch connector
- Water temp. sender gauge connector
- Water temp. sensor connector
- Oil pressure sender gauge connector
- Oxygen sensor connector

14. (7M-GTE)

INSTALL IGNITION COIL WITH BRACKET
 (See steps 13, 14 on pages EM-13, 14)

15. INSTALL AIR INTAKE CHAMBER WITH CONNECTOR

- (a) Position a new gasket on the intake manifold.
- (b) (7M-GTE)
Connect the cold start injector connector.

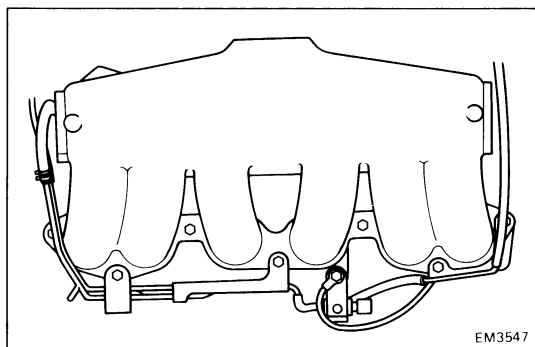

- (c) Install the intake chamber with connector and vacuum transmitting pipes with the two nuts and five bolts.

Torque: 180 kg-cm (13 ft-lb, 18 N·m)

- (d) Connect the engine wire to the clamps of the intake chamber.

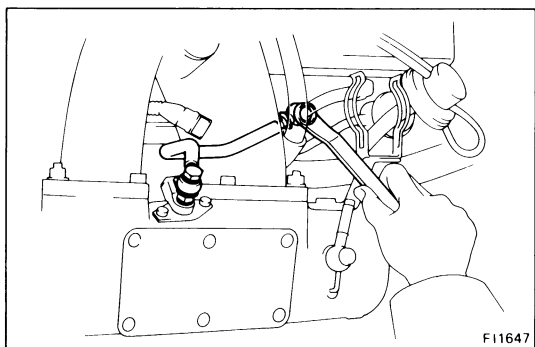

- (e) Install new gaskets and cold start injector tube.

**Torque: To delivery pipe
300 kg-cm (22 ft-lb, 29 N·m)
To cold start injector
180 kg-cm (13 ft-lb, 18 N·m)**

- (f) Install the EGR vacuum modulator to the bracket.

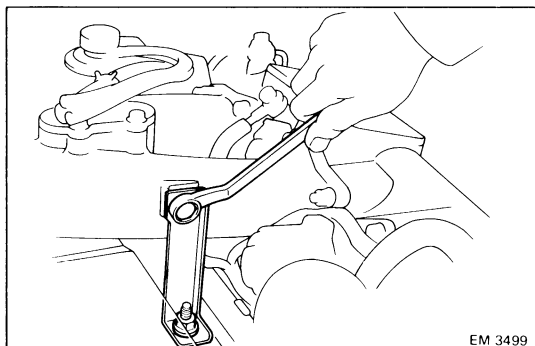

- (g) (7M-GE)
Install the air intake connector bracket mounting bolts.

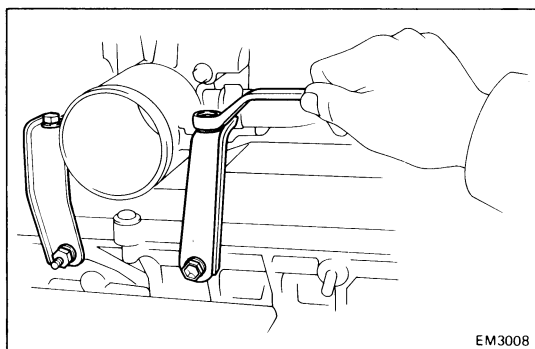

- (h) (7M-GE)
Install the throttle body brackets.

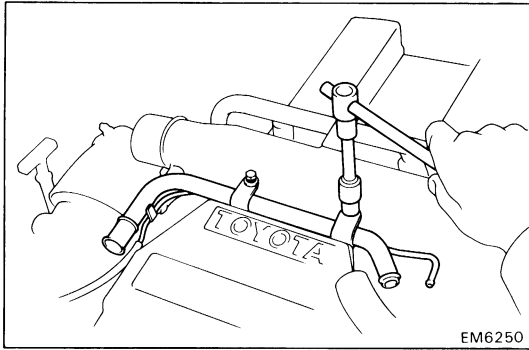

- (i) (7M-GTE)
Install the ISC pipe and connect the hoses.

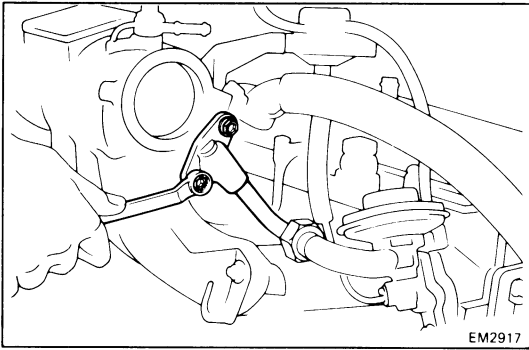

- (j) Install the EGR pipe mounting bolts.
(k) Install the manifold stay mounting bolt.
(l) Connect the following hoses:
- (7M-GE)
No.3 water by-pass hose to throttle body
 - (7M-GTE)
No.3 water by-pass hose to water by-pass pipe
 - No.1 water by-pass hose to union of cylinder block
 - (7M-GTE)
Auxiliary air pipe hose to vacuum transmitting pipe
 - (7M-GE)
Diaphragm hose
 - (7M-GTE)
VSV hoses (for FPU)
 - PS air hose
 - Pressure regulator hose
 - Vacuum transmitting pipe hose to intake chamber
 - EGR hoses to throttle body and vacuum transmitting pipe.
 - BSVS hose to throttle body
- (m) Connect the following wires:
- ISC valve connector
 - Throttle position sensor connector
 - (7M-GE)
Cold start injector connector
- (n) Install the PCV pipe.

**16. (7M-GTE)
INSTALL CAM POSITION SENSOR
(See steps 1, 2 on page IG-24)**

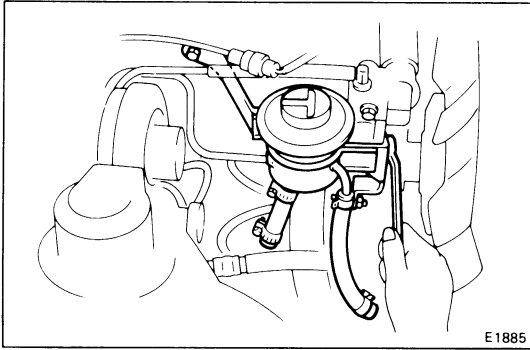

**17. (7M-GTE)
INSTALL PS RESERVOIR TANK**

Install the PS reservoir tank with bracket.

18. INSTALL ALTERNATOR AND ADJUSTING BAR

- (a) Install the alternator and adjusting bar.
- (b) Install the drive belt.
(See page MA-6)
- (c) Connect the No.3 PCV pipe.

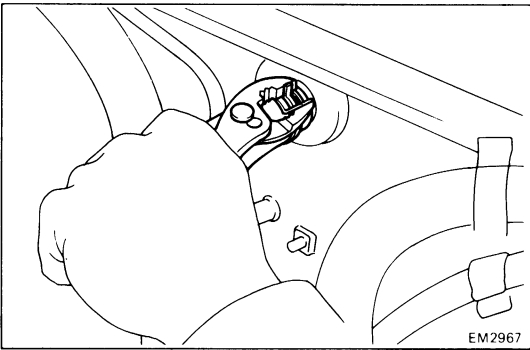

19. CONNECT HEATER INLET HOSE

20. INSTALL RADIATOR INLET HOSE

21. CONNECT FOLLOWING HOSES:

- (a) Charcoal canister hose
- (b) Cruise control vacuum hose
- (c) Brake booster hose

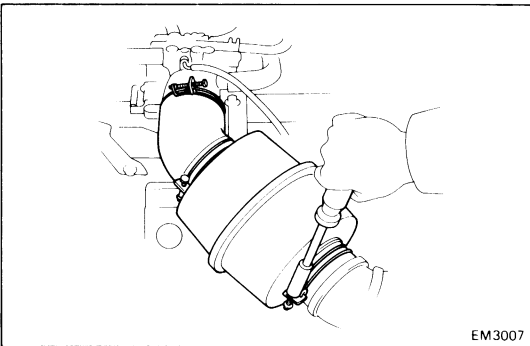

**22. (7M-GE)
INSTALL NO.1 AIR CLEANER HOSE WITH INTAKE AIR
CONNECTOR PIPE**

**(7M-GTE)
INSTALL NO.4 AIR CLEANER PIPE WITH NO.1 AND NO.2
AIR CLEANER HOSES**

23. CONNECT GROUND STRAP TO ENGINE REAR SIDE

24. CONNECT FOLLOWING CABLES AND ROD:

- (a) (A/T)
Throttle cable
- (b) Accelerator rod
- (c) Accelerator link w/ cable

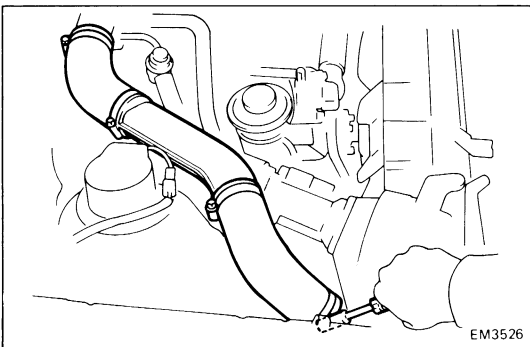

25. **CONNECT EXHAUST PIPE TO EXHAUST MANIFOLD**
26. **FILL WITH COOLANT**
(See page CO-5)
27. **CONNECT CABLE TO NEGATIVE TERMINAL OF BATTERY**
28. **START ENGINE**
Warm up the engine and check for leaks.
29. **PERFORM ENGINE ADJUSTMENT**
Recheck the ignition timing.
30. **ROAD TEST**
Road test vehicle.
31. **RECHECK COOLANT AND ENGINE OIL LEVELS**

CYLINDER BLOCK COMPONENTS

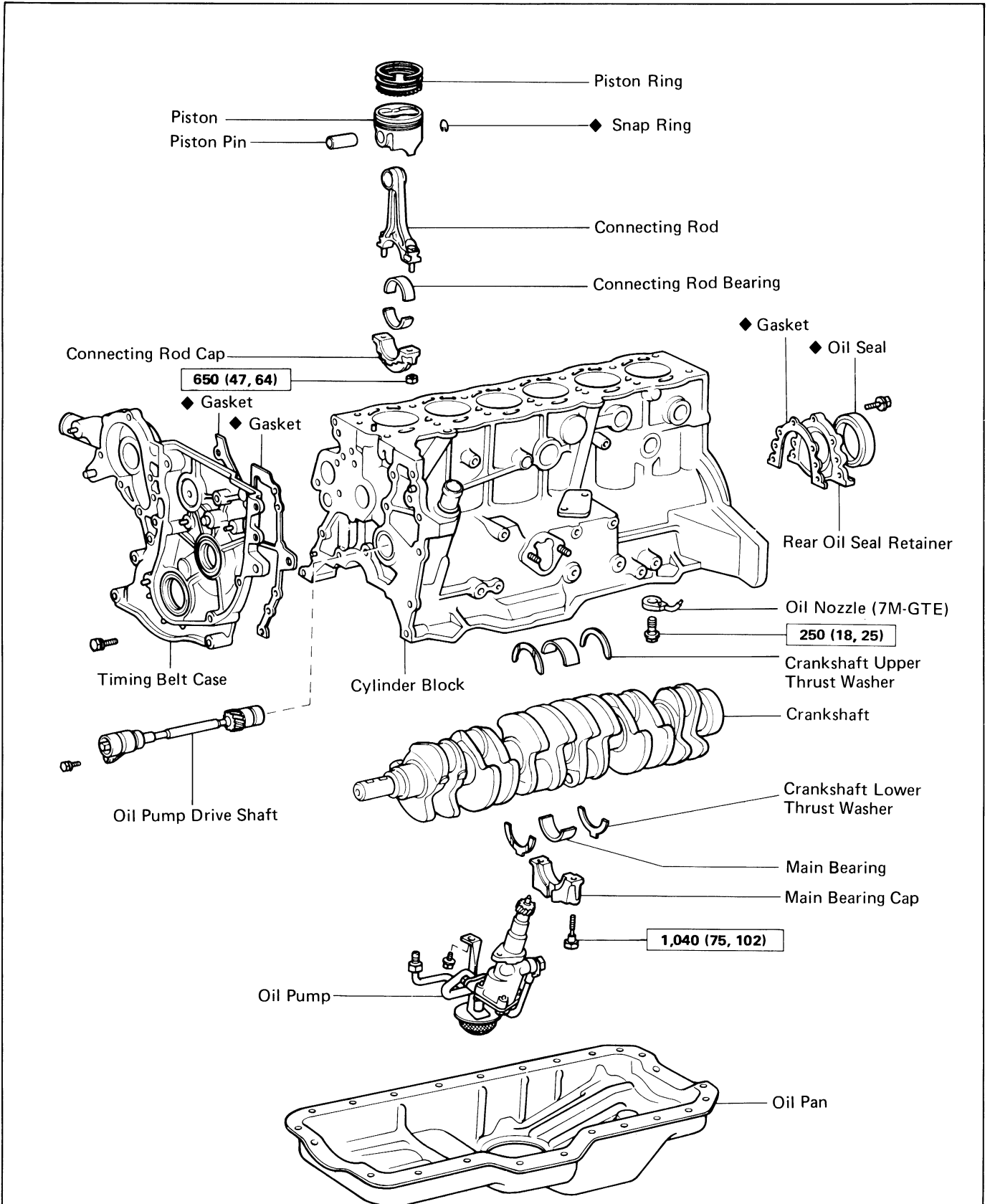

kg-cm (ft-lb, N-m) : Specified torque

◆ Non-reusable part

REMOVAL OF ENGINE

1. REMOVE HOOD
2. DISCONNECT CABLE FROM NEGATIVE TERMINAL OF BATTERY

CAUTION: Work must be started after approx. 20 seconds or longer from the time the ignition switch is turned to the "LOCK" position and the negative (–) terminal cable is disconnected from the battery.

3. REMOVE ENGINE UNDER COVER

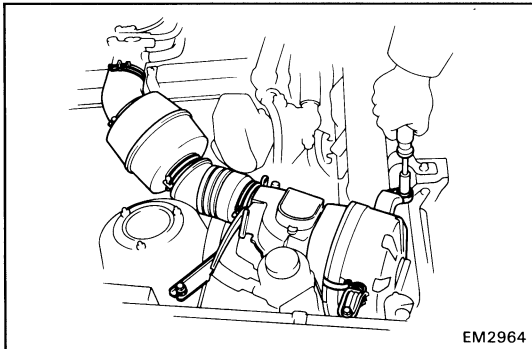

4. DRAIN COOLANT FROM RADIATOR AND CYLINDER BLOCK
(See page CO-5)

5. DRAIN ENGINE OIL

6. (7M-GE)
REMOVE AIR CLEANER CASE WITH HOSES

- (a) Disconnect the air flow meter connector.
- (b) Disconnect the PS air hose.
- (c) Remove the three bolts and air cleaner case with hoses.

- (7M-GTE)
REMOVE NO.4 AIR CLEANER PIPE WITH NO.1 AND NO.2 AIR CLEANER HOSES

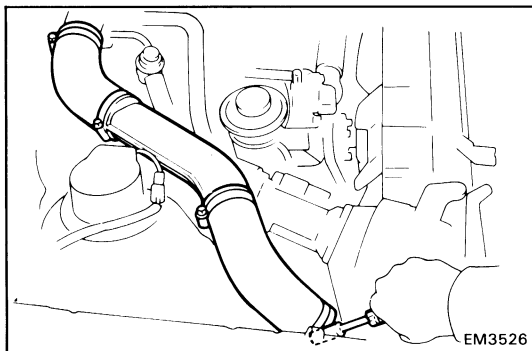

7. REMOVE NO.7 AIR CLEANER HOSE WITH AIR FLOW METER AND AIR CLEANER CAP

- (a) Disconnect the three air hoses and PCV hose.
- (b) Disconnect the air flow meter connector.
- (c) Disconnect the PS air hose.

8. REMOVE RADIATOR
(See page CO-9)

9. REMOVE A/C BELT

10. REMOVE ALTERNATOR DRIVE BELT, WATER PUMP PULLEY AND FLUID COUPLING

11. REMOVE PS BELT

12. DISCONNECT FOLLOWING HOSES:

- (a) Brake booster hose
- (b) Heater valve hose
- (c) Cruise control hose
- (d) Charcoal canister hose

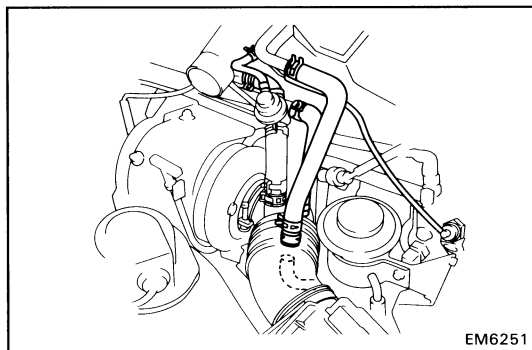

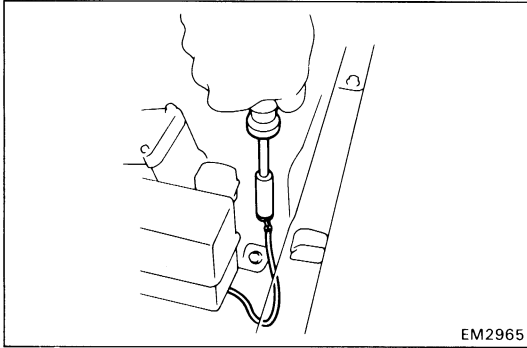
**13. DISCONNECT FOLLOWING CONNECTORS AND WIRES:**

- (a) Ground strap from LH front fender apron
- (b) Battery positive cable from battery
- (c) Noise filter connector
- (d) Theft deterrent horn connector
- (e) Check connector
- (f) (7M-GTE)
Solenoid resistor connector
- (g) (7M-GT)
Ignition coil connector
(7M-GTE)
Igniter connectors
- (h) Main relay connector
- (i) Alternator connector and wire
- (j) (7M-GE)
Oxygen sensor connector
- (k) Heater valve connector
- (l) Ground strap from engine rear side
- (m) Engine and ECT connectors

14. DISCONNECT FOLLOWING CABLES:

- (a) Cruise control cable
- (b) Accelerator cable
- (c) (A/T)
Throttle cable

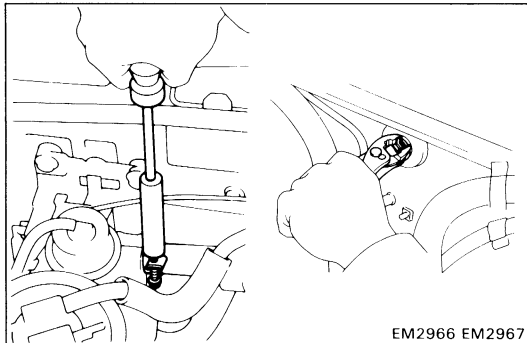
**15. DISCONNECT HEATER HOSES****16. REMOVE A/C COMPRESSOR WITHOUT DISCONNECTING HOSES****17. (7M-GTE)
REMOVE NO.6 AIR CLEANER HOSE****18. (7M-GTE)
REMOVE RADIATOR OUTLET HOSE****19. REMOVE PS PUMP WITHOUT DISCONNECTING HOSES****20. (M/T)
REMOVE SHIFT LEVER****21. DISCONNECT GROUND STRAP FROM FUEL HOSE CLAMP****22. (7M-GTE)
REMOVE ENGINE MOUNTING ABSORBER**

23. **DISCONNECT FUEL PIPES**
24. **REMOVE EXHAUST PIPE**
25. **REMOVE PROPELLER SHAFT**
(See page PR-3)
26. **DISCONNECT SPEEDOMETER CABLE**
27. (A/T)
REMOVE MANUAL SHIFT LINKAGE
28. **REMOVE NO.1 FRONT CROSS MEMBER**
29. (M/T)
REMOVE CLUTCH RELEASE CYLINDER
30. **PLACE JACK UNDER TRANSMISSION**
Be sure to put a wooden block between the jack and the transmission oil pan to prevent damage.
31. **INSTALL A WOODEN BLOCK BETWEEN COWL PANEL AND CYLINDER HEAD REAR END TO PREVENT DAMAGE TO HEATER HOSE**
32. **REMOVE ENGINE REAR SUPPORT MEMBER WITH GROUND STRAP FROM BODY**
33. **REMOVE ENGINE WITH TRANSMISSION**
 - (a) Attach the engine hoist chain to the two engine hangers.
 - (b) Remove the mounting nuts and washers.
 - (c) Lift the engine with transmission out of the vehicle slowly and carefully.

HINT: Make sure the engine is clear of all wiring and hoses.
34. **PLACE ENGINE ON TO ENGINE STAND**
35. (A/T)
REMOVE A/T OIL COOLER PIPES
36. **REMOVE TRANSMISSION**
37. (7M-GE)
REMOVE CLUTCH COVER AND DISC
(See page CL-11)

DISASSEMBLY OF CYLINDER BLOCK

(See page EM-63)

1. REMOVE FLYWHEEL OR DRIVE PLATE AND REAR END PLATE
2. INSTALL ENGINE STAND FOR DISASSEMBLY
3. REMOVE TIMING BELT
(See steps 3, 7, 9 and 11 to 17 on pages EM-22 to 25)
4. REMOVE CYLINDER HEAD
(See steps 1 to 15 and 18 on pages EM-35 to 39)

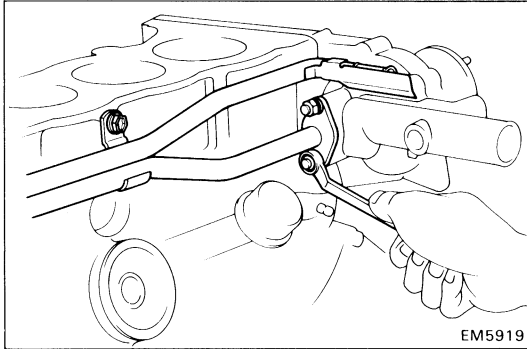

5. REMOVE WATER BY-PASS PIPE AND HOSES
 - (a) Remove the two nuts from the timing belt case.
 - (b) Remove the three bolts from the cylinder block and the water by-pass pipe and hose with gasket.
6. REMOVE GROUND STRAP FROM CYLINDER BLOCK
7. (7M-GE)
REMOVE VACUUM CONTROL VALVE SET

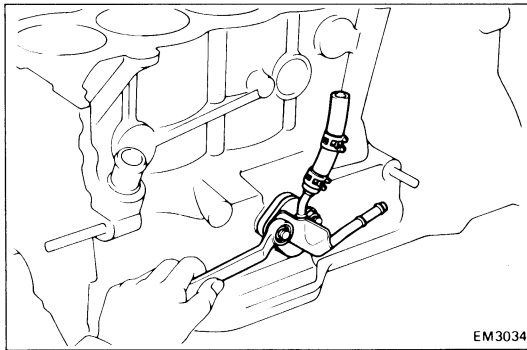

8. REMOVE FUEL RETURN PIPE SUPPORT
Remove the two nuts, fuel pipe support and insulator.

9. REMOVE ENGINE MOUNTING BRACKETS

10. (7M-GE)
REMOVE OIL FILTER
(See page LU-5)
(7M-GTE)
REMOVE OIL FILTER BRACKET
(See step 4 on page LU-16)

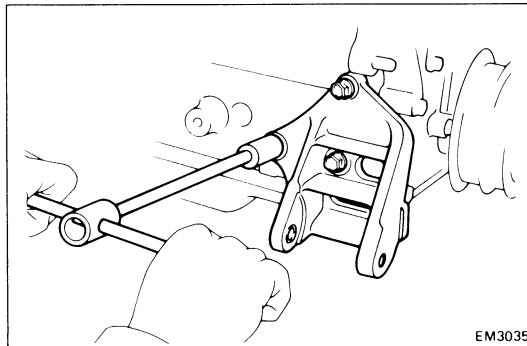

11. (7M-GE)
REMOVE OIL HOLE COVER PLATE

12. REMOVE PS PUMP BRACKET

13. REMOVE OIL PAN
(See step 15 on page LU-9)

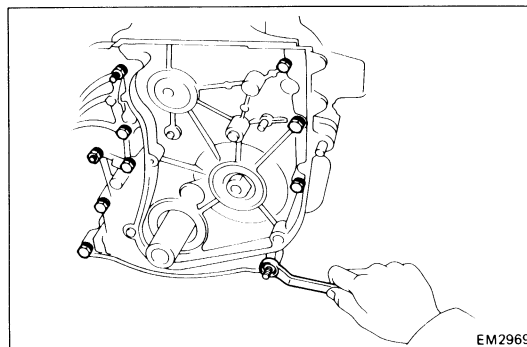

14. REMOVE TIMING BELT CASE WITH WATER PUMP
Remove the seven bolts and three nuts, and remove the timing belt case and gaskets.

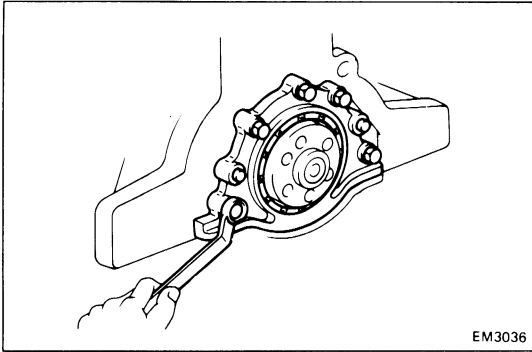

EM3036

15. REMOVE REAR OIL SEAL RETAINER

Remove the five bolts, and remove rear oil seal retainer and gasket.

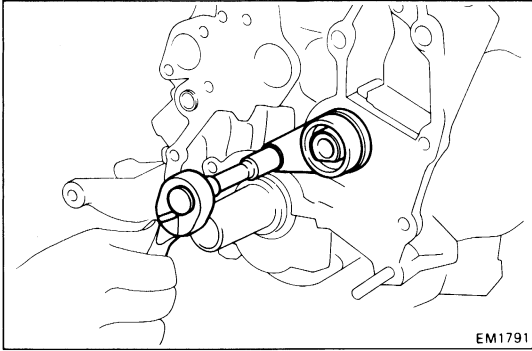

EM1791

16. REMOVE OIL PUMP DRIVE SHAFT

- (a) Remove the bolt and oil pump drive shaft.
- (b) While turning oil pump drive shaft, slowly pull out so as not to damage the bearing.

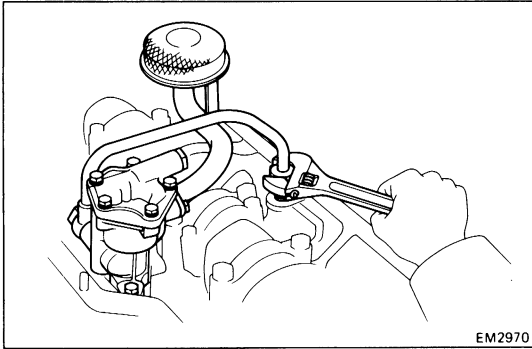

EM2970

17. REMOVE OIL PUMP

- (a) Loosen the union nut.
- (b) Remove the two bolts, and remove the oil pump.

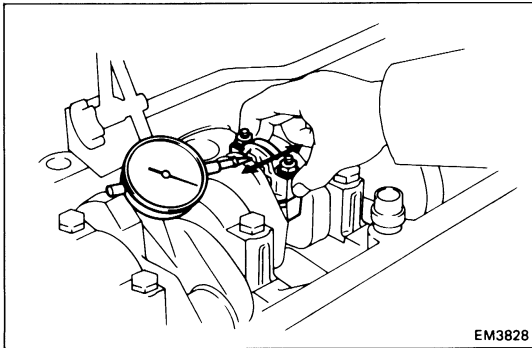

EM3828

18. CHECK CONNECTING ROD THRUST CLEARANCE

Using a dial gauge, measure the thrust clearance.

Standard clearance: 0.160 – 0.296 mm

(0.0063 – 0.0117 in.) 0.0171

Maximum clearance: 0.3 mm (0.012 in.) (Worj)

If clearance is greater than maximum, replace the connecting rod and/or crankshaft.

19. REMOVE CONNECTING ROD CAPS AND CHECK OIL CLEARANCE

- (a) Using a punch or numbering stamp, place matchmarks on the connecting rod and cap to ensure correct reassembly.
- (b) Remove the rod cap nuts.

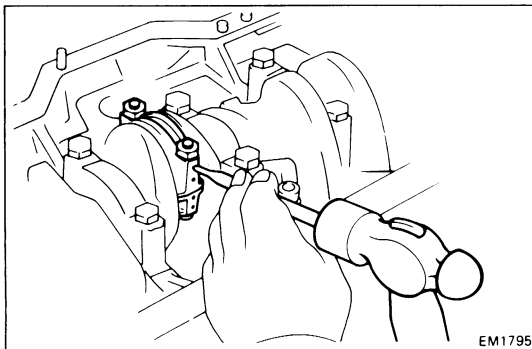

EM1795

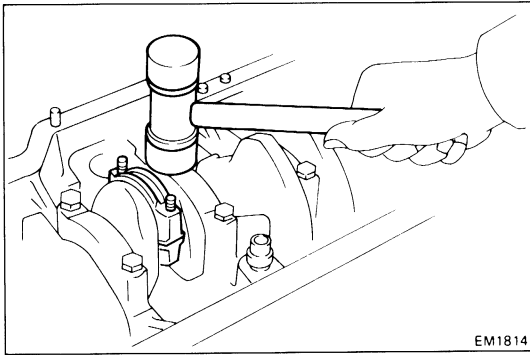

(c) Using a plastic-faced hammer, tap the rod bolts lightly and lift off the rod cap.

HINT: Keep the lower bearing inserted with the cap.

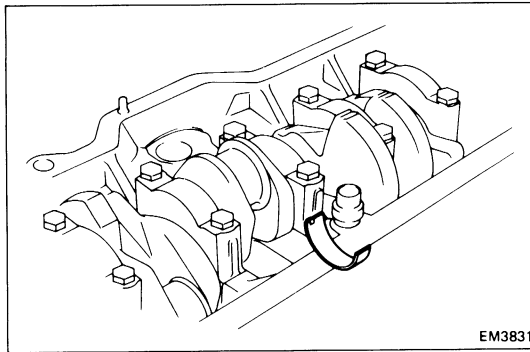

(d) Clean the bearings and crankshaft pins.

(e) Inspect each bearing for pitting and radial scratches.

If bearings are damaged, replace the bearings.

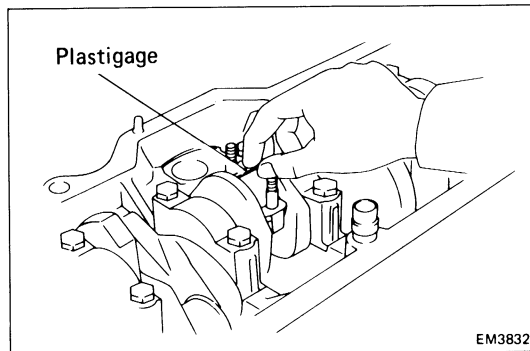

(f) Lay a strip of Plastigage across the crankshaft pin.

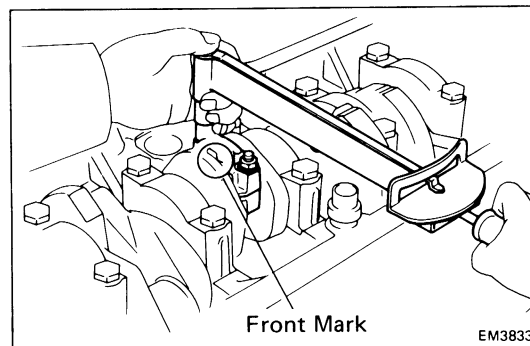

(g) Align the rod and cap marks and fit on the cap.
Torque the rod cap nuts.

Torque: 650 kg-cm (47 ft-lb, 64 N·m)

HINT: Do not turn the crankshaft.

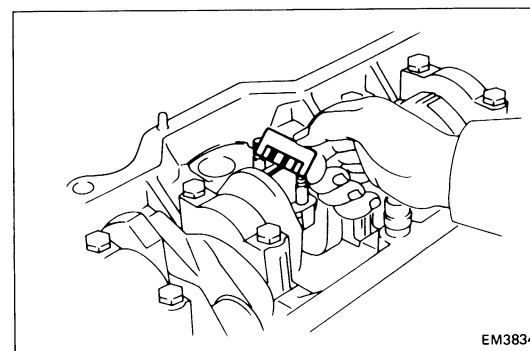

(h) Remove the rod cap.

(i) Measure the plastigage at its widest point.

**Standard clearance: 0.021 — 0.053 mm
(0.0008 — 0.0021 in.)**

Maximum clearance: 0.07 mm (0.0028 in.)

If the clearance is greater than maximum, replace the bearings and/or grind the crank pins.

Undersized bearing: U/S 0.25

(j) Clean any Plastigage from the bearing and crankshaft pin.

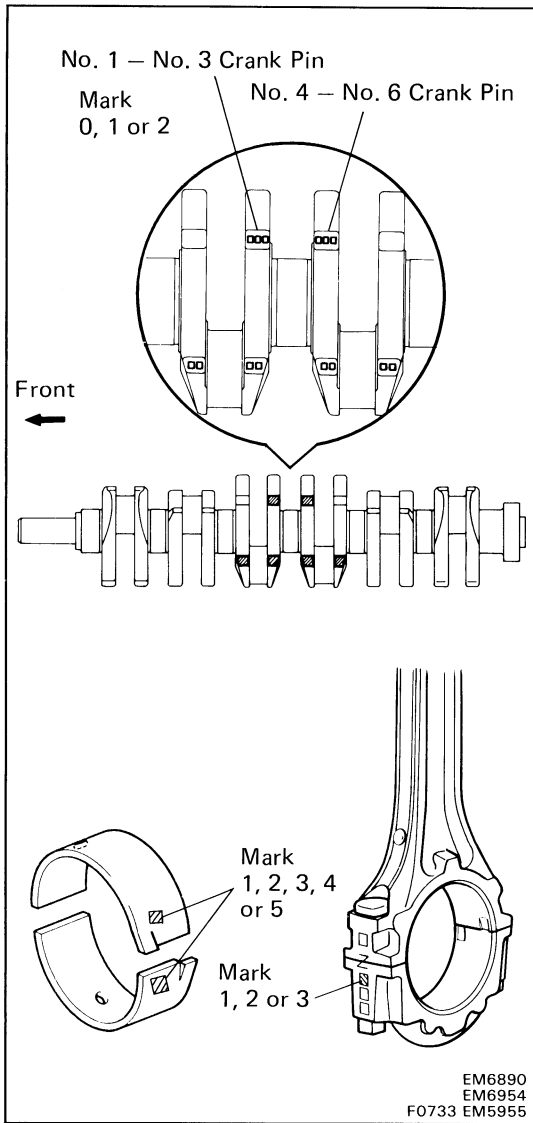

HINT: If using a standard size bearing, replace with one having the same number. If the number of the bearing cannot be determined, select a bearing from the table below according to the numbers imprinted on the connecting rod cap and crankshaft. There are five sizes of standard bearings, marked "1", "2", "3", "4" and "5" accordingly.

| | Number marked | | | | | | | | |
|------------|---------------|---|---|---|---|---|---|---|---|
| Rod cap | 1 | 1 | 2 | 1 | 2 | 3 | 2 | 3 | 3 |
| Crankshaft | 0 | 1 | 0 | 2 | 1 | 0 | 2 | 1 | 2 |
| Bearing | 1 | 2 | 2 | 3 | 3 | 3 | 4 | 4 | 5 |

Example: Rod cap "2", Crankshaft "1" = Bearing "3"
(Reference)

| Mark | mm (in.) | | |
|-------------|--------------------------------------|--------------------------------------|------------------------------------|
| | Big End Inner Diameter | Crank Pin Diameter | Bearing Center Wall Thickness |
| 0 | — | 51.993 – 52.000 (2.0470 – 2.0472) | — |
| 1 | 55.015 – 55.025 (2.1659 – 2.1663) | 51.985 – 51.992 (2.0446 – 2.0469) | 1.490 – 1.495 (0.0587 – 0.0589) |
| 2 | 55.026 – 55.035 (2.1664 – 2.1667) | 51.976 – 51.984 (2.0463 – 2.0466) | 1.496 – 1.500 (0.0589 – 0.0591) |
| 3 | 55.036 – 55.045 (2.1668 – 2.1671) | — | 1.501 – 1.505 (0.0591 – 0.0593) |
| 4 | — | — | 1.506 – 1.510 (0.0593 – 0.0594) |
| 5 | — | — | 1.511 – 1.515 (0.0595 – 0.0596) |
| U/S 0.25 | 55.015 – 55.045 (2.1659 – 2.1671) | 51.725 – 51.735 (2.0364 – 2.0368) | 1.622 – 1.632 (0.0639 – 0.0643) |

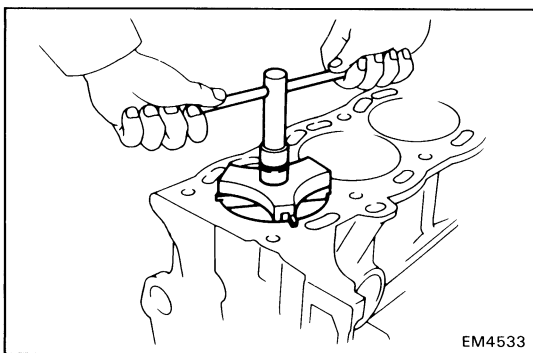

20. REMOVE PISTON AND CONNECTING ROD ASSEMBLIES

(a) Remove all the carbon from the top of the cylinder.

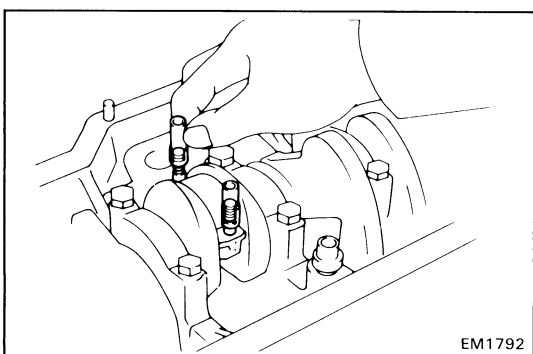

(b) Cover the rod bolts with a short piece of hose to protect the crank pin from damage.

(c) Push the piston and connecting rod assembly out through the top of the cylinder block.

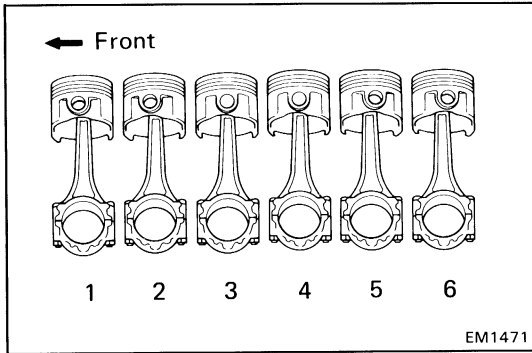

- (d) Arrange the pistons and connecting rod caps in order.

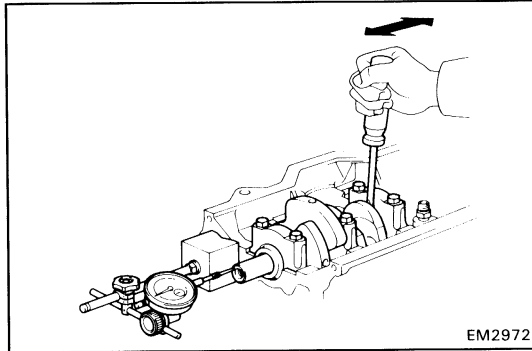

21. CHECK CRANKSHAFT THRUST CLEARANCE

Using a dial gauge, measure the crankshaft thrust clearance while prying the crankshaft back and forth with a screwdriver.

Standard clearance: 0.05 – 0.25 mm
(0.0020 – 0.0098 in.)

Maximum clearance: 0.30mm (0.0118 in.)

If the clearance is greater than maximum, replace the thrust washers as a set and/or crankshaft.

HINT: Thrust washer thickness:

STD 2.925 – 2.975 mm (0.1152 – 0.1171 in.)
O/S 0.125 2.988 – 3.038 mm (0.1176 – 0.1196 in.)

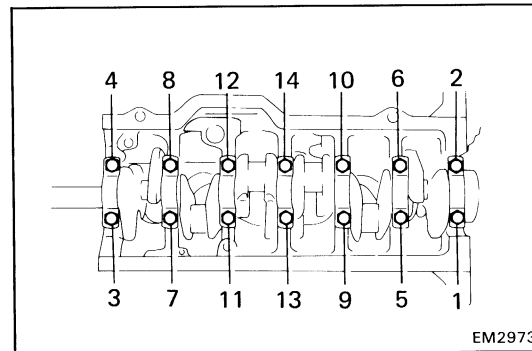

22. REMOVE MAIN BEARING CAPS AND CHECK OIL CLEARANCE

- (a) Uniformly loosen and remove the main bearing cap bolts in several passes, in the sequence shown.

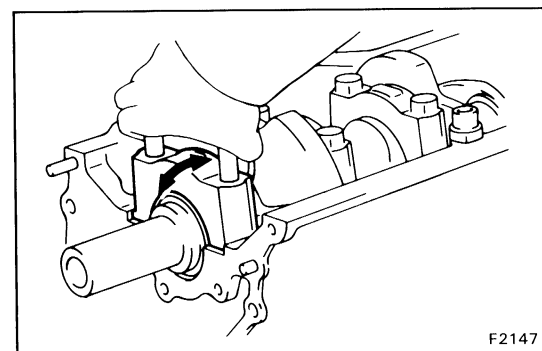

- (b) Using the removed bearing cap bolts, wiggle the bearing cap back and forth, and remove it with the lower bearing and thrust washers (No.4 journal only).

HINT:

- Keep the lower bearing inserted with the cap.
- Arrange the caps and lower thrust washers in correct order.

- (c) Lift off the crankshaft.

HINT: Keep the upper bearings and upper thrust washers (for the No.4 journal only) inserted in the cylinder block.

- (d) Clean the journals and bearings.

- (e) Check the journals and bearings for pitting and scratches.

If the journal or a bearing is damaged, grind or replace the crankshaft and replace the bearings.

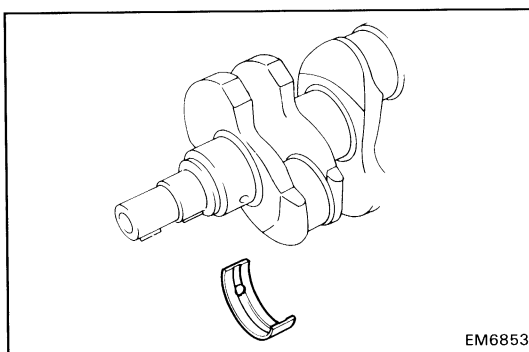

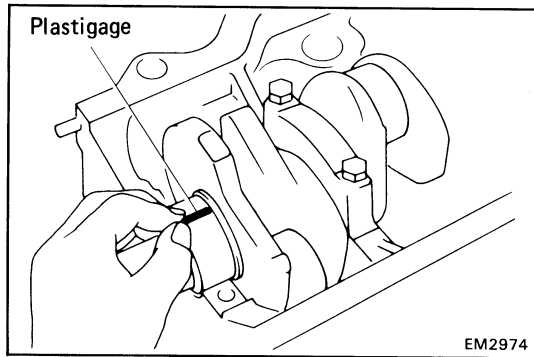

- (f) Install the upper main bearing on the cylinder block and crankshaft.
- (g) Lay a strip of Plastigage across the main journals.

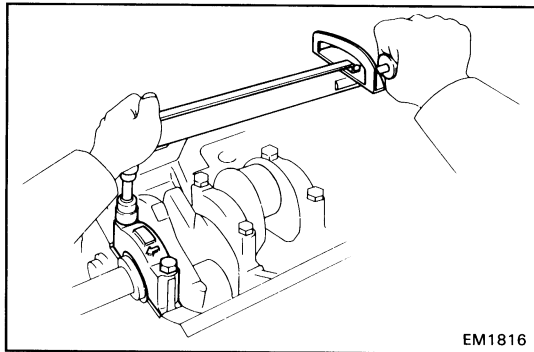

- (h) Install the main bearing caps. Torque the cap bolts.
Torque: 1,040 kg-cm (75 ft-lb, 102 N·m)
HINT: Do not turn crankshaft.

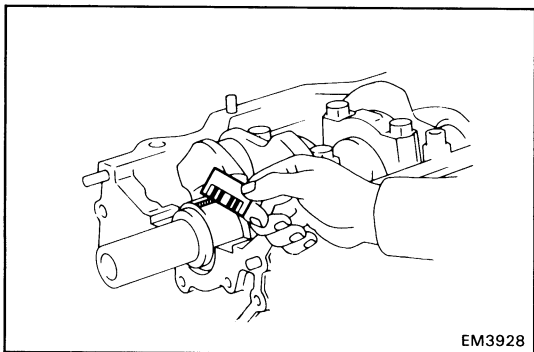

- (i) Remove the main bearing caps.
- (j) Measure the Plastigage at its widest point.

Standard clearance: 0.030 — 0.048 mm
 (0.0012 — 0.0019 in.)

Maximum clearance: 0.07 mm (0.0028 in.)

If the oil clearance is greater than maximum, replace the bearings. If necessary, replace the crankshaft.

Undersized bearing: U/S 0.25

HINT: If using a standard size bearing, replace with one having the same number. If the number of the bearing cannot be determined, select a bearing from the table below according to the numbers imprinted on the cylinder block and crankshaft. There are five sizes of standard bearings, marked "1", "2", "3", "4" and "5" accordingly.

| | Number marked | | | | | | | | |
|----------------|---------------|---|---|---|---|---|---|---|---|
| | 1 | 1 | 2 | 1 | 2 | 3 | 2 | 3 | 3 |
| Cylinder Block | 1 | 1 | 2 | 1 | 2 | 3 | 2 | 3 | 3 |
| Crankshaft | 0 | 1 | 0 | 2 | 1 | 0 | 2 | 1 | 2 |
| Bearing | 1 | 2 | 2 | 3 | 3 | 3 | 4 | 4 | 5 |

Example: Cylinder Block "2", Crankshaft "1" = Bearing "3"

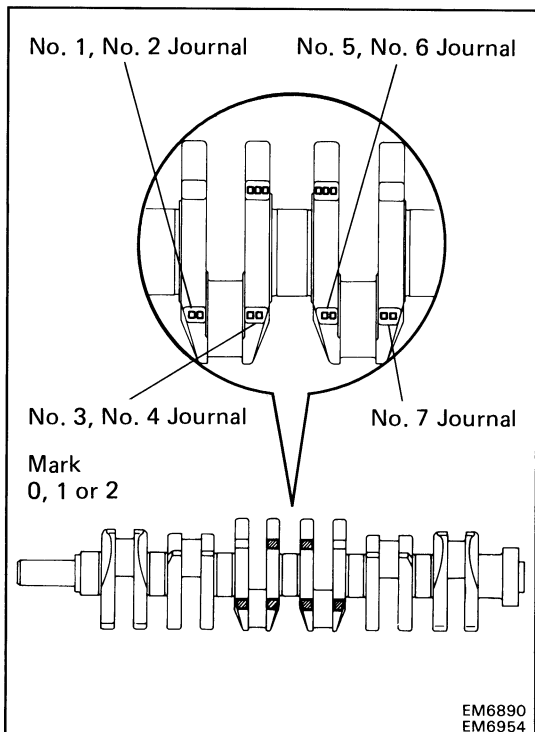

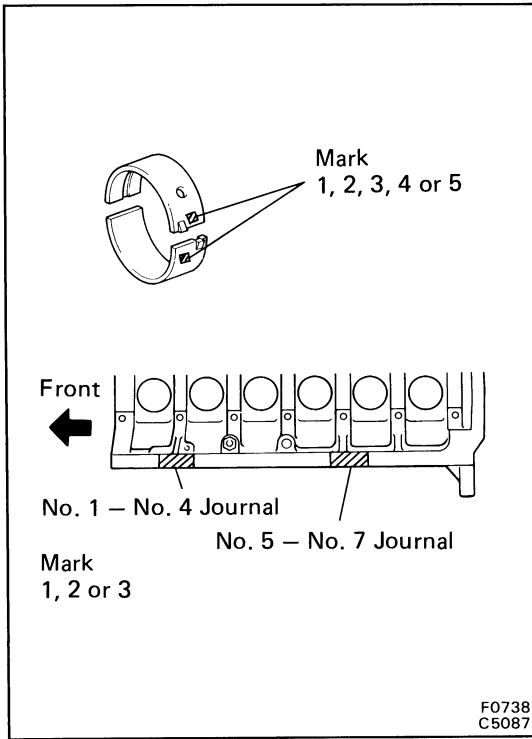

(Reference)

mm (in.)

| Mark | Cylinder Block Main Journal Bore | Main Journal Diameter | Bearing Center Wall Thickness |
|-------------|--------------------------------------|--------------------------------------|------------------------------------|
| 0 | — | 60.007 – 60.012 (2.3625 – 2.3627) | — |
| 1 | 64.024 – 64.030 (2.5206 – 2.5209) | 60.001 – 60.006 (2.3622 – 2.3624) | 1.988 – 1.991 (0.0783 – 0.0784) |
| 2 | 64.031 – 64.036 (2.5209 – 2.5211) | 59.994 – 60.000 (2.3620 – 2.3622) | 1.992 – 1.994 (0.0784 – 0.0785) |
| 3 | 64.037 – 64.042 (2.5211 – 2.5213) | — | 1.995 – 1.997 (0.0785 – 0.0786) |
| 4 | — | — | 1.998 – 2.000 (0.0787 – 0.0787) |
| 5 | — | — | 2.001 – 2.003 (0.0788 – 0.0789) |
| U/S 0.25 | 64.022 – 64.046 (2.5205 – 2.5215) | 59.730 – 59.740 (2.3516 – 2.3520) | 2.123 – 2.133 (0.0086 – 0.0840) |

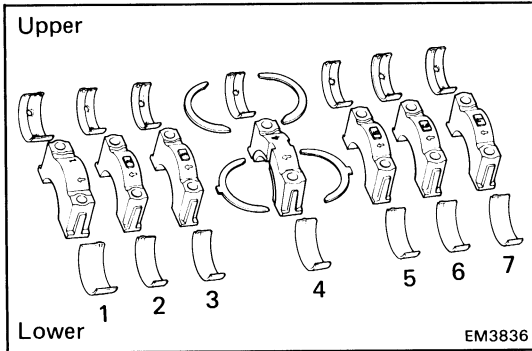

23. REMOVE CRANKSHAFT

- (a) Lift out the crankshaft.
- (b) Remove the upper main bearings and upper thrust washers from the cylinder block.
- (c) Clean out the scraps of Plastigage from bearing and journals.

HINT:

- Arrange the caps, bearings and thrust washers in correct order.
- The pilot bearing in the crankshaft rear end is permanently lubricated and requires no cleaning or lubrication.

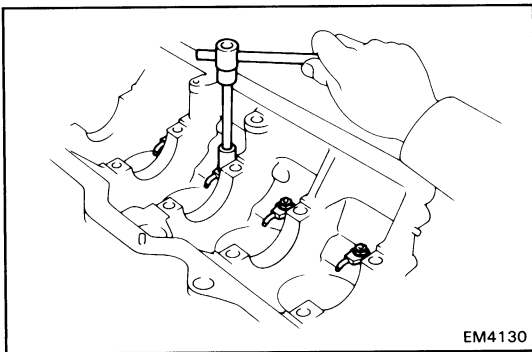

24. (7M-GTE) REMOVE OIL NOZZLES

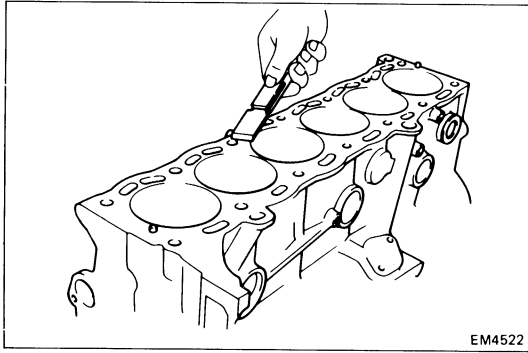

INSPECTION OF CYLINDER BLOCK

1. REMOVE GASKET MATERIAL

Using a gasket scraper, remove all the gasket material from the cylinder block surface.

2. CLEAN CYLINDER BLOCK

Using a soft brush and solvent, clean the block.

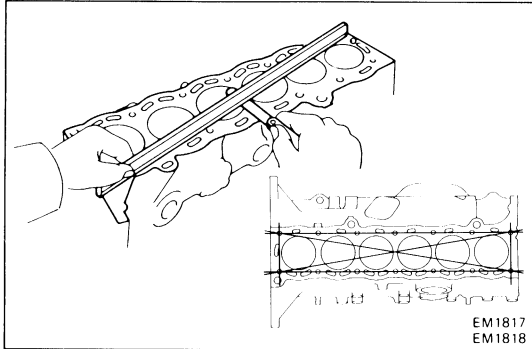

3. INSPECT TOP OF CYLINDER BLOCK FOR FLATNESS

Using a precision straight edge and thickness gauge, measure the surfaces contacting the cylinder head gasket for warpage.

Maximum warpage: 0.05 mm (0.0020 in.)

If warpage is greater than maximum, replace the cylinder block.

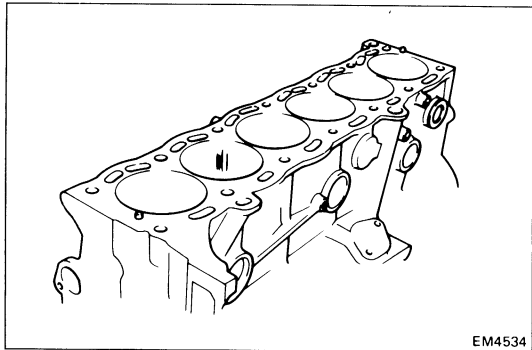

4. INSPECT CYLINDERS FOR VERTICAL SCRATCHES

Visually check the cylinder for vertical scratches.

If deep scratches are present, rebore all six cylinders. If necessary, replace the cylinder block.

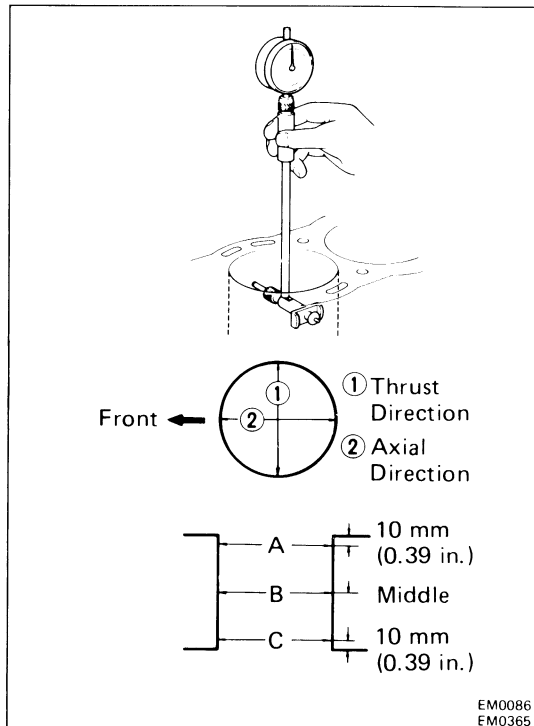

5. INSPECT CYLINDER BORE DIAMETER

Using a cylinder gauge, measure the cylinder bore diameter at positions A, B and C in the thrust and axial directions.

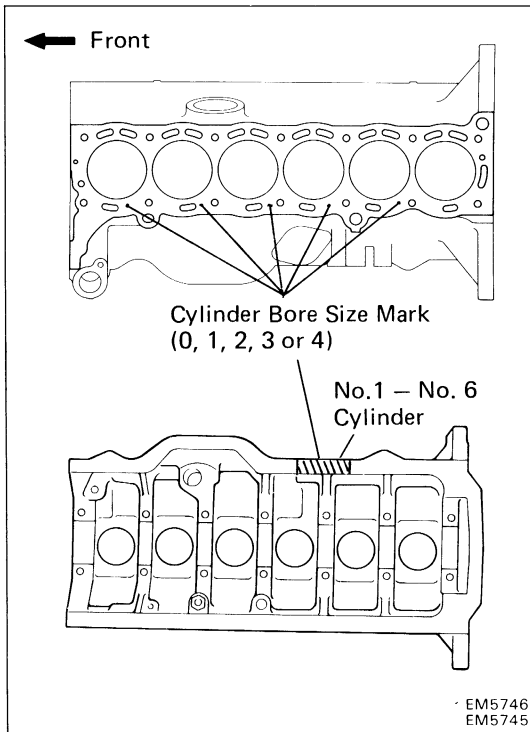

HINT: There are five sizes of standard cylinder bore diameter, marked "0", "1", "2", "3" and "4" accordingly. The mark is stamped on the cylinder block as shown in the illustration.

Standard cylinder bore diameter:

STD size

| | |
|----------|---|
| Mark "0" | 82.990 — 83.000 mm (3.2673 — 3.2677 in.) |
| Mark "1" | 83.001 — 83.010 mm (3.2677 — 3.2681 in.) |
| Mark "2" | 83.011 — 83.020 mm (3.2681 — 3.2685 in.) |
| Mark "3" | 83.021 — 83.030 mm (3.2685 — 3.2689 in.) |
| Mark "4" | 83.031 — 83.040 mm (3.2689 — 3.2693 in.) |

Maximum cylinder bore diameter:

| | |
|----------|-----------------------|
| STD size | 83.24 mm (3.2772 in.) |
| O/S 0.50 | 83.74 mm (3.2968 in.) |

If the diameter is greater than maximum, rebore all six cylinders. If necessary, replace the cylinder block.

6. REMOVE CYLINDER RIDGES

If the wear is less than 0.2 mm (0.008 in.), use a ridge reamer to machine the top of the cylinder.

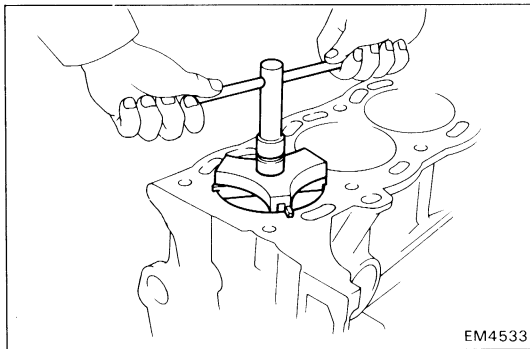

DISASSEMBLY OF PISTON AND CONNECTING ROD ASSEMBLIES

(See page EM-63)

1. CHECK FIT BETWEEN PISTON AND PIN

Try to move the piston back and forth on the piston pin. If any movement is felt, replace the piston and pin as a set.

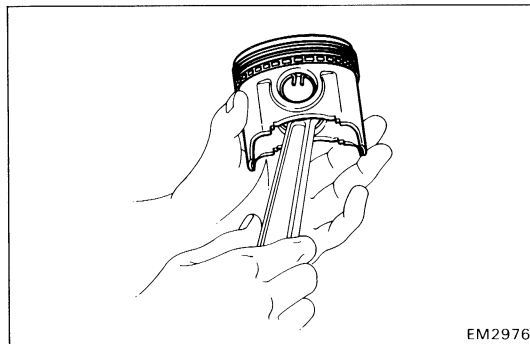

2. REMOVE PISTON RINGS

(a) Using a piston ring expander, remove the compression rings.

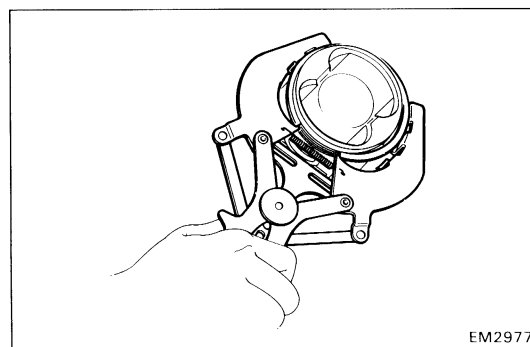

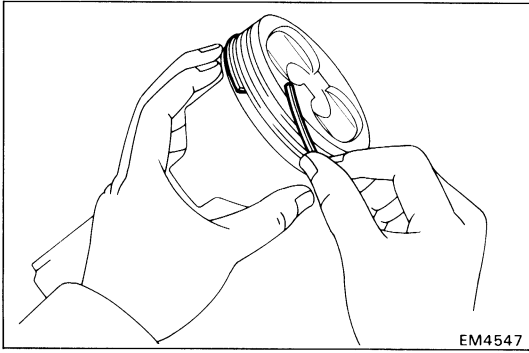

(b) Remove the two side rails and oil ring expander by hand.

HINT: Arrange the rings in correct order.

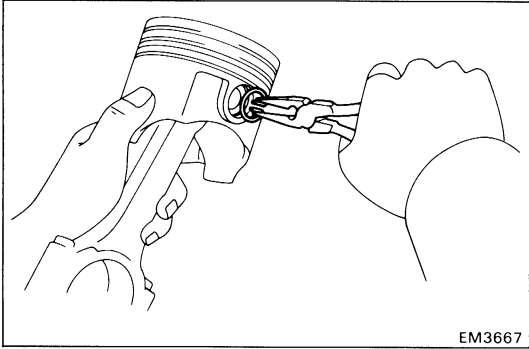

3. DISCONNECT CONNECTING ROD FROM PISTON

(a) Using needle-nose pliers, remove the snap rings from the piston.

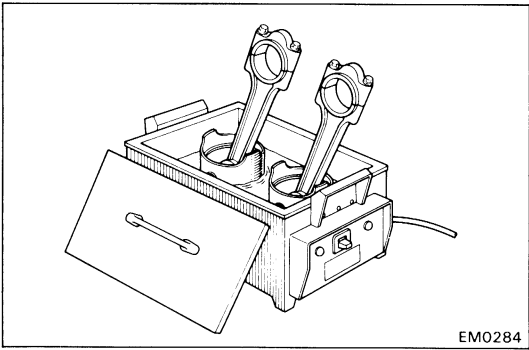

(b) Gradually heat the piston to approx. 60°C (140°F).

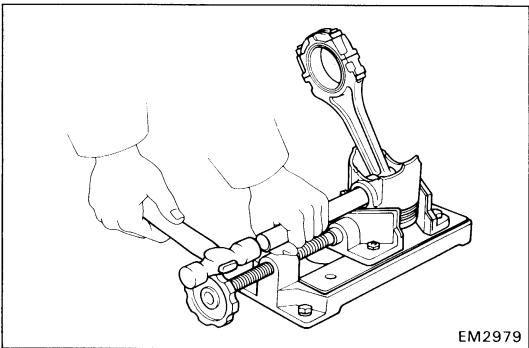

(c) Using a plastic-faced hammer and brass bar, lightly tap out the piston pin and remove the connecting rod.

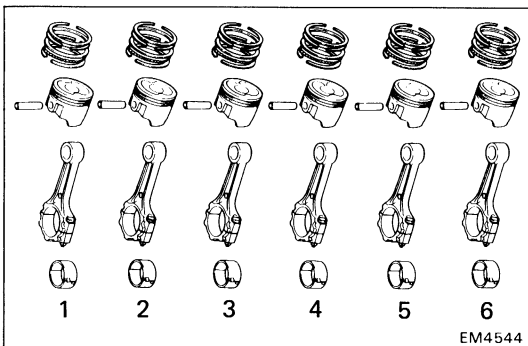

HINT:

- The piston and pin are a matched set.
- Arrange the pistons, pins, rings, connecting rods and bearings in correct order.

INSPECTION OF PISTON AND CONNECTING ROD ASSEMBLIES

1. CLEAN PISTON

- (a) Using a gasket scraper, remove the carbon from the piston top.

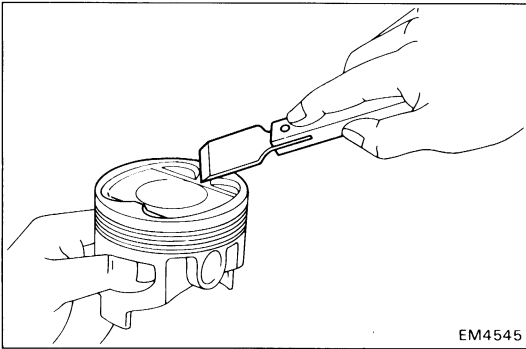

- (b) Using a groove cleaning tool or broken ring, clean the ring grooves.

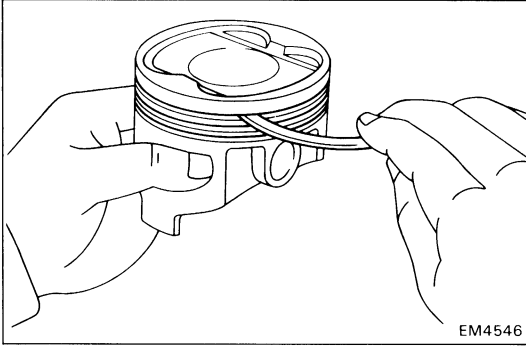

- (c) Using a soft brush and solvent, thoroughly clean the piston.

NOTICE: Do not damage the piston.

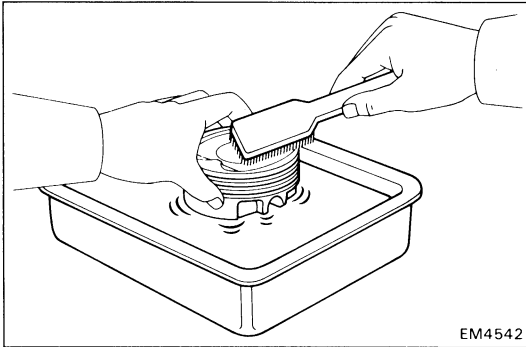

2. INSPECT PISTON DIAMETER AND OIL CLEARANCE

- (a) Using a micrometer, measure the piston diameter at a right angle to the piston pin hole center line, 22 mm (0.87 in.) from the piston head.

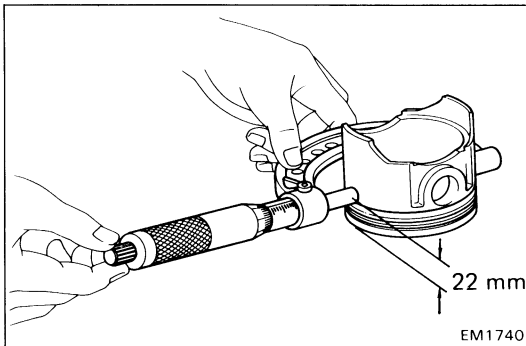

HINT: There are five sizes of standard piston diameter, marked "0", "1", "2", "3" and "4" accordingly. The mark is stamped on the piston as shown in the illustration.

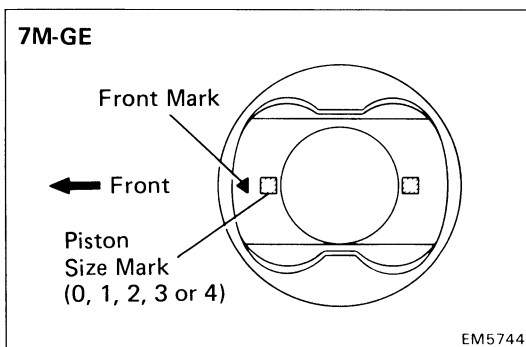

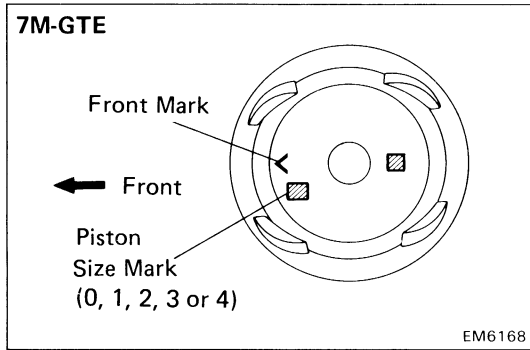

Piston diameter:

STD size

| | | |
|---------------|-----------------|--|
| 7M-GE | Mark "0" | 82.900 — 82.910 mm (3.2638 — 3.2642 in.) |
| | Mark "1" | 82.911 — 82.920 mm (3.2642 — 3.2646 in.) |
| | Mark "2" | 82.921 — 82.930 mm (3.2646 — 3.2650 in.) |
| | Mark "3" | 82.931 — 82.940 mm (3.2650 — 3.2653 in.) |
| | Mark "4" | 82.941 — 82.950 mm (3.2654 — 3.2657 in.) |
| 7M-GTE | Mark "0" | 82.910 — 82.920 mm (3.2642 — 3.2646 in.) |
| | Mark "1" | 82.921 — 82.930 mm (3.2646 — 3.2650 in.) |
| | Mark "2" | 82.931 — 82.940 mm (3.2650 — 3.2653 in.) |
| | Mark "3" | 82.941 — 82.950 mm (3.2654 — 3.2657 in.) |
| | Mark "4" | 82.951 — 82.960 mm (3.2658 — 3.2661 in.) |

O/S 0.50

| | |
|---------------|--|
| 7M-GE | 83.40 — 83.45 mm (3.2835 — 3.2854 in.) |
| 7M-GTE | 83.41 — 83.46 mm (3.2839 — 3.2858 in.) |

- (b) Measure the cylinder bore diameter in thrust directions. (See page EM-74)
- (c) Subtract the piston diameter measurement from the cylinder bore diameter measurement.

Standard oil clearance:

| | |
|---------------|---|
| 7M-GE | 0.08 — 0.10 mm (0.0031 — 0.0039 in.) |
| 7M-GTE | 0.07 — 0.09 mm (0.0028 — 0.0035 in.) |

Maximum oil clearance: 0.13 mm (0.0051 in.)

If the oil clearance is greater than maximum, replace the piston. If necessary, rebore all six cylinders and replace all six pistons. If necessary, replace the cylinder block.

HINT: (Use cylinder block sub-assembly)

When installing a standard piston, install one with the same mark as the standard bore diameter mark on the cylinder block.

3. INSPECT CLEARANCE BETWEEN WALL OF RING GROOVE AND NEW PISTON RING

Using a thickness gauge, measure the clearance between new piston ring and the wall of the piston ring groove.

Ring groove clearance:

| | |
|-------------|---|
| No.1 | 0.03 — 0.07 mm (0.0012 — 0.0028 in.) |
| No.2 | 0.02 — 0.06 mm (0.0008 — 0.0024 in.) |

If the clearance is not within specification, replace the piston.

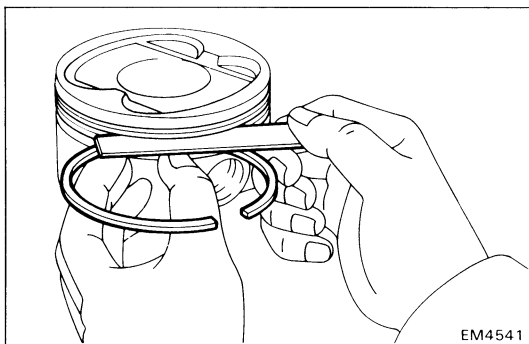

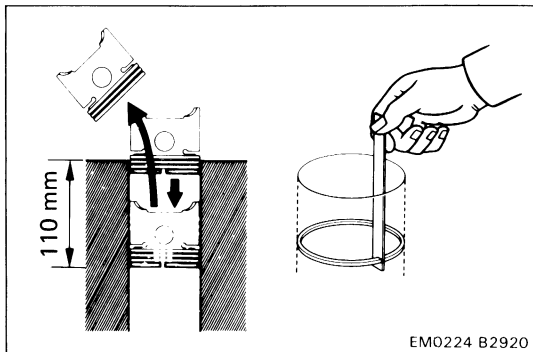

4. INSPECT PISTON RING END GAP

- (a) Insert the piston ring into the cylinder.
- (b) Using a piston, push the ring a little beyond the bottom of the ring travel. (110 mm (4.33 in.) from the top surface of cylinder block)
- (c) Using a thickness gauge, measure the end gap.

Ring end gap:

mm (in.)

| | No.1 | | No.2 | | Oil | |
|--------|----------------------------------|------------------|----------------------------------|------------------|----------------------------------|------------------|
| | STD | Limit | STD | Limit | STD | Limit |
| 7M-GE | 0.23 – 0.38 (0.0091 – 0.0150) | 0.68 (0.0268) | 0.25 – 0.53 (0.0098 – 0.0209) | 1.13 (0.0445) | 0.10 – 0.40 (0.0039 – 0.0157) | 1.00 (0.0394) |
| 7M-GTE | 0.29 – 0.44 (0.0114 – 0.0173) | 0.74 (0.0291) | | | 0.10 – 0.44 (0.0039 – 0.0173) | 1.04 (0.0409) |

(.017")

If the diameter is greater than maximum, rebore all six cylinders, or replace the cylinder block.

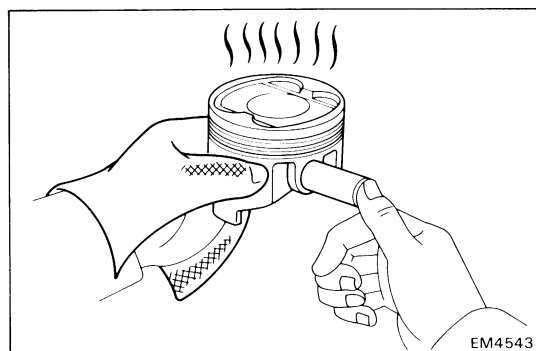

5. CHECK PISTON PIN FIT

- At 60°C (140°F) you should be able to push the pin into the piston with your thumb.
- If the pin can be installed at a lower temperature, replace the piston.

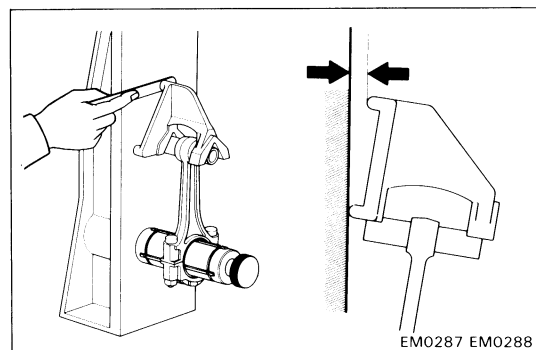

6. INSPECT CONNECTING ROD

- (a) Using a rod aligner and thickness gauge, check the connecting rod alignment.
 - Check for bend.

Maximum bend:

0.05 mm (0.0020 in.) per 100 mm (3.94 in.)

If bend is greater than maximum, replace the connecting rod assembly.

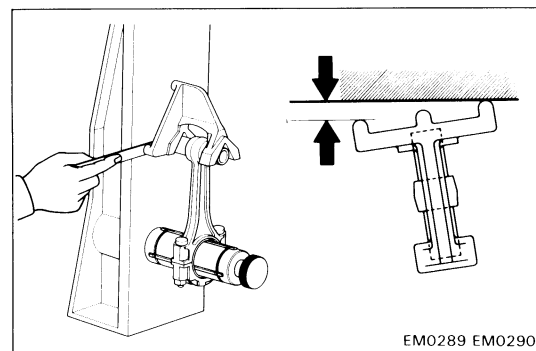

- Check for twist.

Maximum twist:

0.15 mm (0.0059 in.) per 100 mm (3.94 in.)

If twist is greater than maximum, replace the connecting rod assembly.

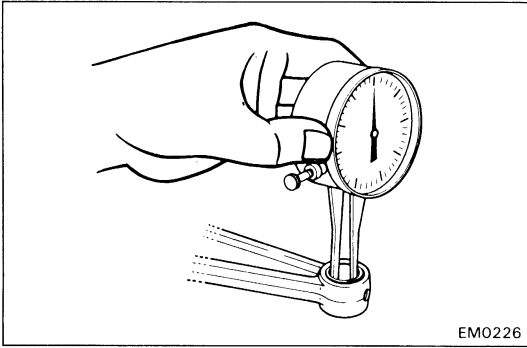

(b) Inspect the oil clearance between the rod bushing and piston pin.

- Using a caliper gauge, measure the inside diameter of the connecting rod bushing.

Bushing inside diameter: 22.005 – 22.017 mm
(0.8663 – 0.8668 in.)

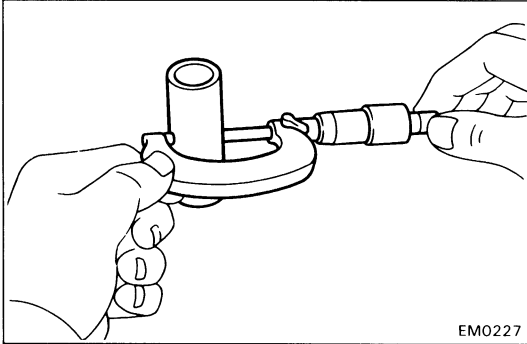

- Using a micrometer, measure the piston pin diameter.

Piston pin diameter: 21.996 – 22.009 mm
(0.8660 – 0.8665 in.)

- Subtract the piston pin diameter measurement from the bushing inside diameter measurement.

Standard oil clearance: 0.005 – 0.011 mm
(0.0002 – 0.0004 in.)

Maximum oil clearance: 0.02 mm (0.0008 in.)

If the oil clearance is greater than maximum, replace the bushing. If necessary, replace the piston and piston pin assembly.

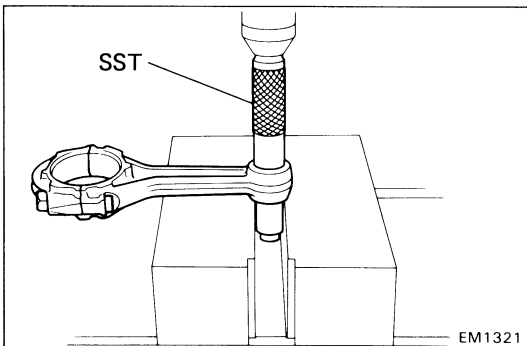

7. IF NECESSARY, REPLACE CONNECTING ROD BUSHING

(a) Using SST and a press, press out the bushing.

SST 09222-30010

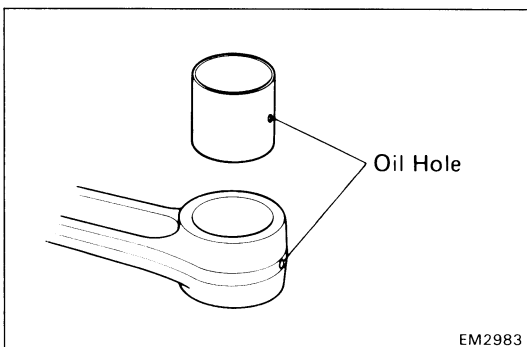

(b) Align the oil holes of a new bushing and connecting rod.

(c) Using SST and a press, press in the bushing.

SST 09222-30010

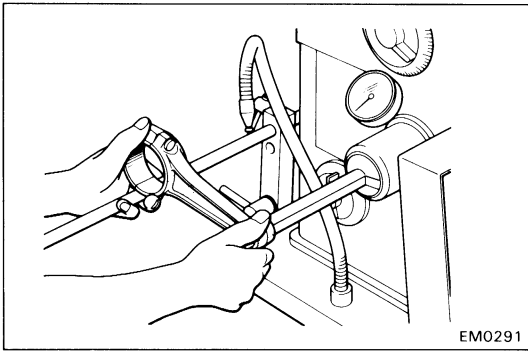

- (d) Using a pin hole grinder, hone the bushing to obtain the specified clearance between the bushing and piston pin.

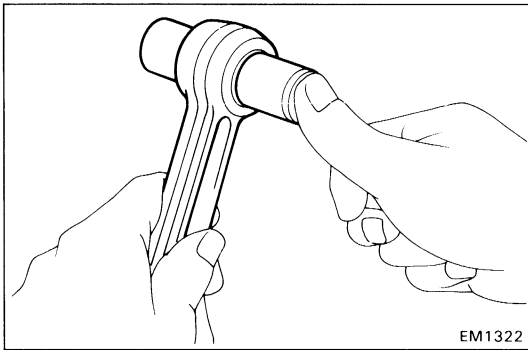

- (e) Check the piston pin fit at normal room temperature. Coat the piston pin with engine oil and push it into the connecting rod with your thumb.

BORING OF CYLINDERS

HINT:

- Bore all six cylinders for the oversized piston outside diameter.
- Replace the piston rings with ones to match the oversized pistons.

1. SELECT OVERSIZED PISTON

Oversized piston diameter:

| | | |
|----------|--------|---|
| O/S 0.50 | 7M-GE | 83.40 — 83.45 mm (3.2835 — 3.2854 in.) |
| | 7M-GTE | 83.41 — 83.46 mm (3.2839 — 3.2858 in.) |

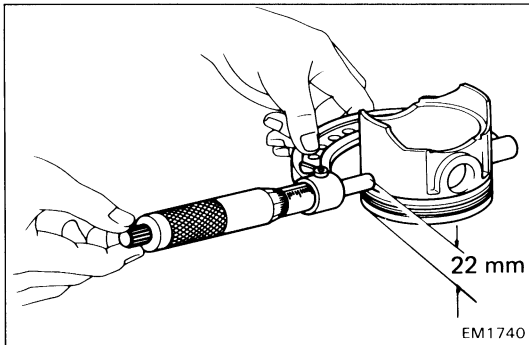

2. CALCULATE AMOUNT TO BORE CYLINDER

- Using a micrometer, measure the piston diameter at a right angle to the piston pin hole center line, 22 mm (0.87 in.) from the piston head.
- Calculate the amount each cylinder is to be rebored as follows:

$$\text{Size to be rebored} = P + C - H$$

P = Piston diameter

C = Piston clearance

| | |
|-------|---|
| 7M-GE | 0.08 — 0.10 mm (0.0020 — 0.0028 in.) |
|-------|---|

| | |
|--------|---|
| 7M-GTE | 0.07 — 0.09 mm (0.0028 — 0.0035 in.) |
|--------|---|

H = Allowance for honing

0.02 mm (0.0008 in.) or less

3. BORE AND HONE CYLINDERS TO CALCULATED DIMENSIONS

Maximum honing: 0.02 mm (0.0008 in.)

NOTICE: Excess honing will destroy the finished roundness.

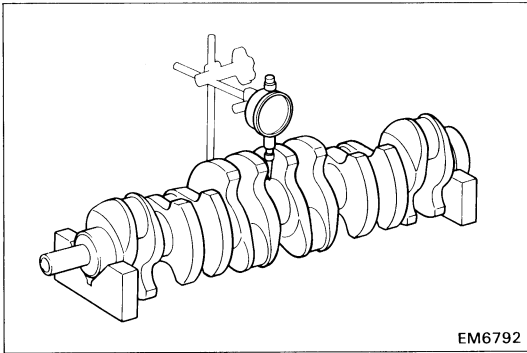

EM6792

INSPECTION AND REPAIR OF CRANKSHAFT

1. INSPECT CRANKSHAFT FOR RUNOUT

- (a) Place the crankshaft on V-blocks.
- (b) Using a dial indicator, measure the circle runout at the center journal.

Maximum circle runout: 0.06 mm (0.0024 in.)

If the circle runout is greater than maximum, replace the crankshaft.

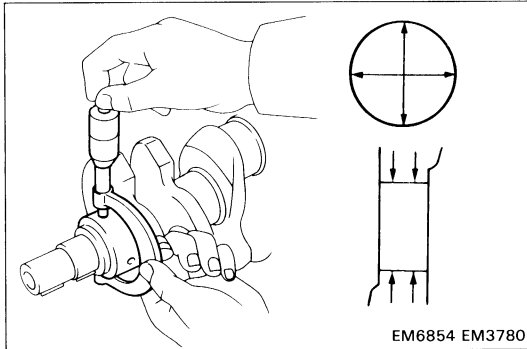

EM6854 EM3780

2. INSPECT MAIN JOURNALS AND CRANK PINS

- (a) Using a micrometer, measure the diameter of each main journal and crank pin.

Journal diameter:

STD size 59.994 – 60.012 mm
(2.3620 – 2.3627 in.)

U/S 0.25 59.730 – 59.740 mm
(2.3516 – 2.3520 in.)

Crank pin diameter:

STD size 51.976 – 52.000 mm
(2.0463 – 2.0472 in.)

U/S 0.25 51.725 – 51.735 mm
(2.0364 – 2.0368 in.)

If the diameter is not within specification, check the oil clearance. If necessary, grind or replace the crankshaft.

- (b) Check each main journal and crank pin for taper and out-of-round as shown.

Maximum taper and out-of-round: 0.02 mm
(0.0008 in.)

If taper or out-of-round is greater than maximum, grind or replace the crankshaft.

3. IF NECESSARY, GRIND AND HONE MAIN JOURNALS AND/OR CRANK PINS

Grind and hone the main journals and/or crank pins to the finished undersized diameter (See procedure step 2).

Install new main journal and/or crank pin undersized bearings.

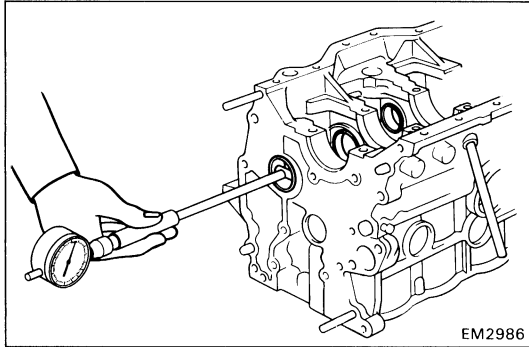
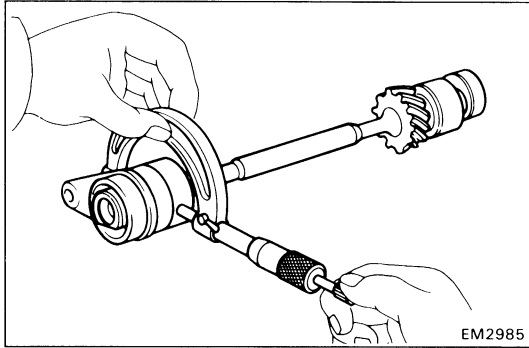

INSPECTION AND REPAIR OF OIL PUMP DRIVE SHAFT, BEARINGS AND BUSHING

1. INSPECT OIL PUMP DRIVE SHAFT

- (a) Using a micrometer, measure the journal diameter of pump drive shaft.

Standard journal diameter:

Front 40.959 – 40.975 mm
(1.6126 – 1.6132 in.)

Rear 32.959 – 32.975 mm
(1.2976 – 1.2982 in.)

- (b) Using a cylinder gauge, measure the inside diameter of the pump drive shaft bearing.

Bearing inside diameter:

Front 41.000 – 41.025 mm
(1.6142 – 1.6152 in.)

Rear 33.000 – 33.025 mm
(1.2992 – 1.3002 in.)

- (c) Subtract the journal diameter measurement from the bearing inside diameter measurement.

Standard oil clearance: 0.025 – 0.066 mm
(0.0010 – 0.0026 in.)

Maximum oil clearance: 0.08 mm (0.0031 in.)

If the clearance is greater than maximum, replace the bearing. If necessary, replace the drive shaft.

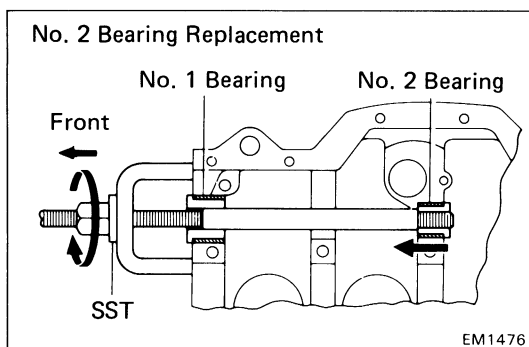
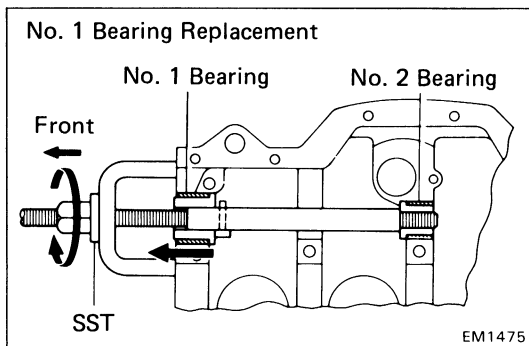

2. IF NECESSARY, REPLACE OIL PUMP DRIVE SHAFT BEARINGS

- (a) Using SST, replace the No.1 bearing by using No.2 bearing as a guide.

SST 09215-00100 (09215-00120, 09215-00130, 09215-00140, 09215-00160, 09215-00210, 09215-00220)

- (b) Using SST, replace the No.2 bearing by using the No.1 bearing as a guide.

SST 09215-00100 (09215-00120, 09215-00130, 09215-00140, 09215-00210, 09215-00220)

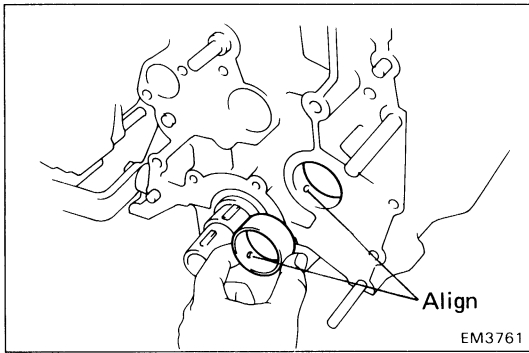

NOTICE: When inserting the bearings, align each oil hole.

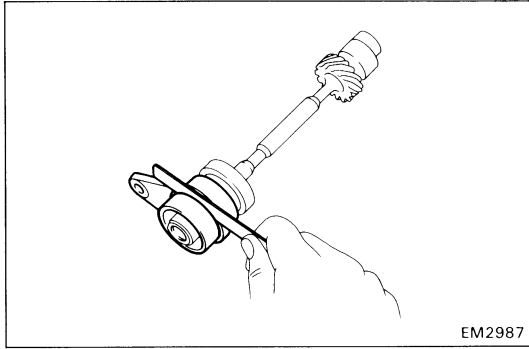

3. INSPECT OIL PUMP DRIVE SHAFT THRUST CLEARANCE

Using a thickness gauge, measure the drive shaft thrust clearance between the thrust plate and collar.

Standard thrust clearance: 0.06 – 0.13 mm
(0.0024 – 0.0051 in.)

Maximum thrust clearance: 0.30 mm (0.0118 in.)

If clearance is greater than maximum, replace the thrust plate and/or collar.

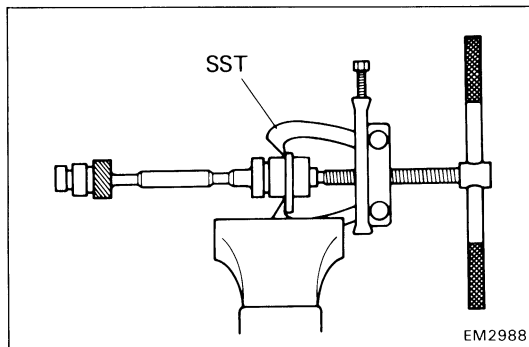

4. IF NECESSARY, REPLACE THRUST PLATE AND COLLAR

(a) Using SST, remove the thrust plate and collar.

SST 09950-20017

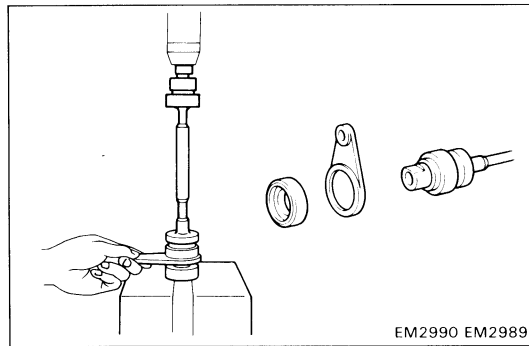

(b) Install the thrust plate and collar in the direction as shown.

(c) Using a press, install the thrust plate and collar.

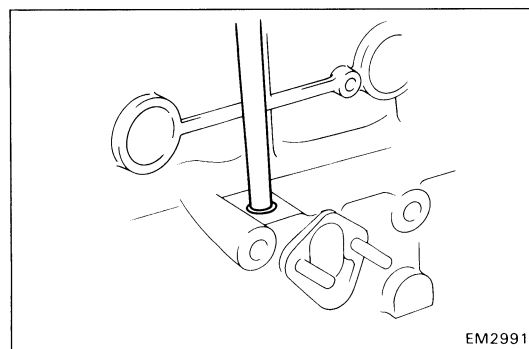

5. IF NECESSARY, REPLACE OIL PUMP GUIDE BUSHING

(a) Drive out the bushing from the outer side of the block.

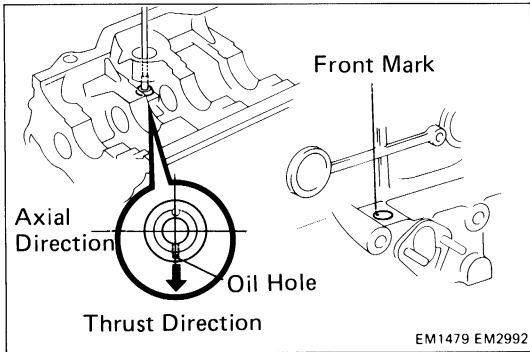

- (b) Drive in the bushing from the inside of the block with a suitable tool.

HINT: The oil hole should be positioned toward the crankshaft side.

- (c) Make sure the front mark of bushing should be positioned toward the front of block.

REPLACEMENT OF OIL SEALS

NOTE: There are two methods (A and B) of oil seal replacement.

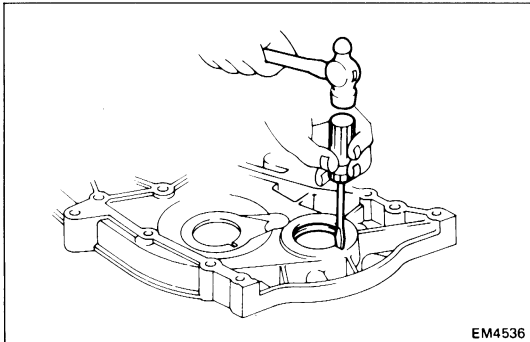

1. REPLACE CRANKSHAFT FRONT OIL SEAL

A. If the timing case is removed from the cylinder block:

- (a) Using a screwdriver and hammer, tap out the oil seal.

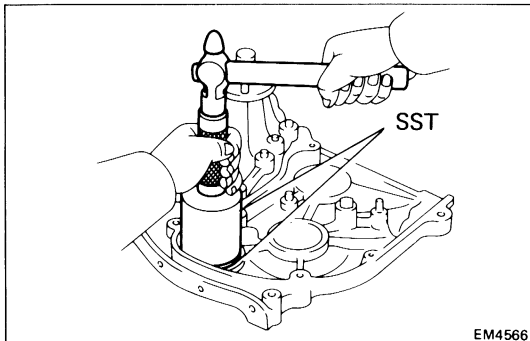

- (b) Using SST and a hammer, tap in a new oil seal.

SST 09214-60010 and 09506-35010

- (c) Apply MP grease to the oil seal lip.

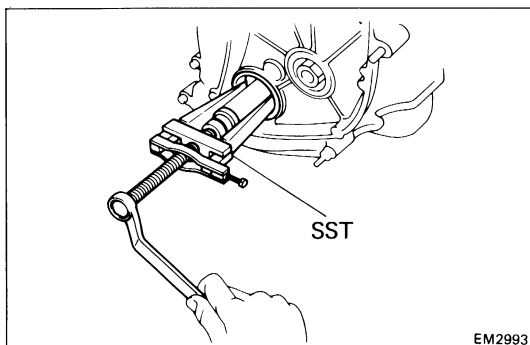

B. If the timing case is installed to the cylinder block:

- (a) Using SST, remove the oil seal.

SST 09308-55010

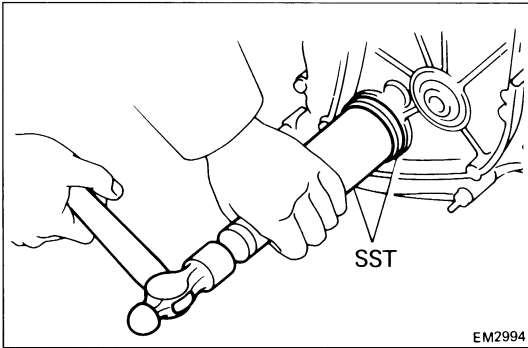

- (b) Apply MP grease to a new oil seal lip.
- (c) Using SST and a hammer, tap in the oil seal.
SST 09214-60010 and 09506-35010

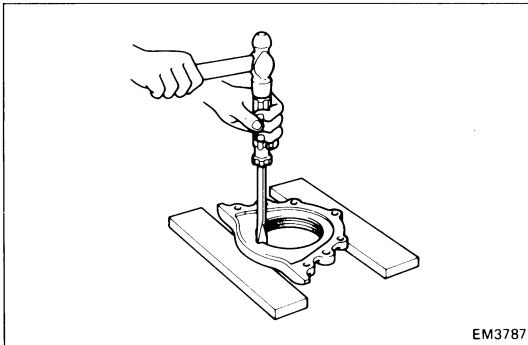

2. REPLACE CRANKSHAFT REAR OIL SEAL

A. If the rear oil seal retainer is removed from the cylinder block:

- (a) Using a screwdriver and hammer, tap out the oil seal.

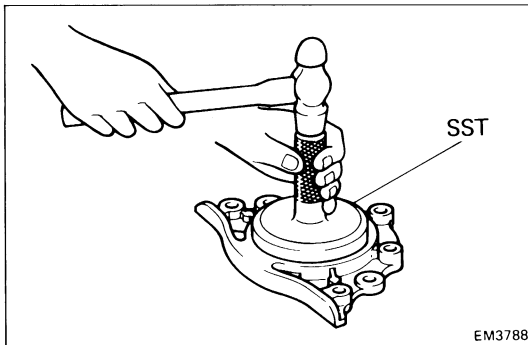

- (b) Using SST and a hammer, tap in a new oil seal.
SST 09223-41020

- (c) Apply MP grease to the oil seal lip.

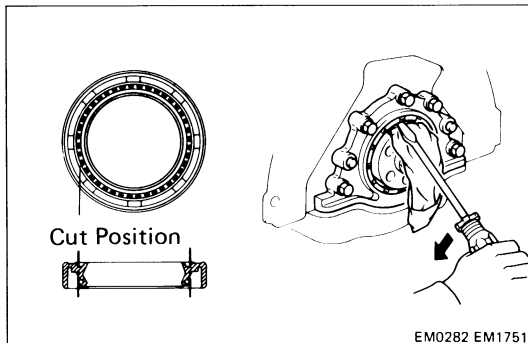

B. If the rear oil seal retainer is installed to the cylinder block:

- (a) Using a knife, cut off the lip of the oil seal as shown.
- (b) Using a screwdriver, pry out the oil seal.

NOTICE: Be careful not to damage the crankshaft. Tape the screwdriver tip.

- (c) Check the oil seal lip contact surface of the crankshaft for cracks or damage.

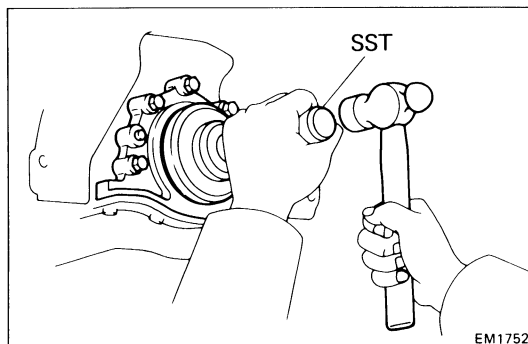

- (d) Apply MP grease to a new oil seal lip.
- (e) Using SST and a hammer, tap in the oil seal.
SST 09223-41020

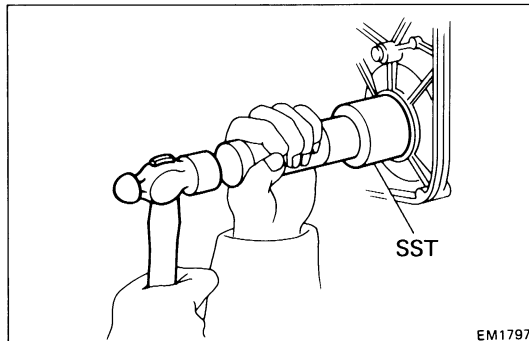
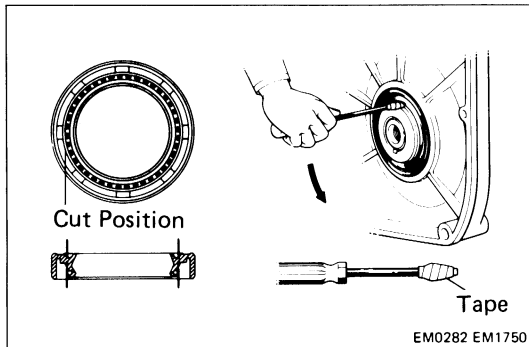
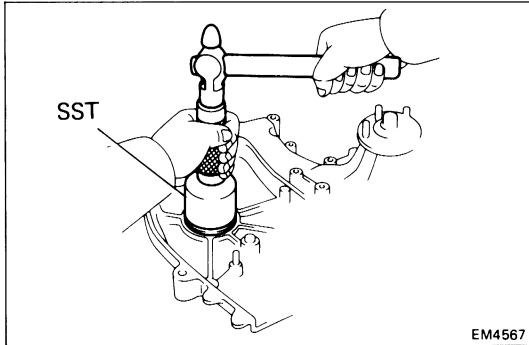
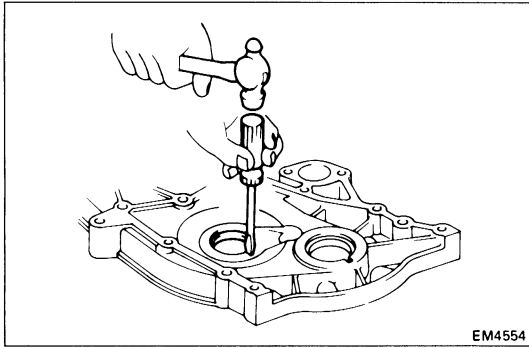

3. REPLACE OIL PUMP DRIVE SHAFT OIL SEAL

A. If the timing belt case is removed from the cylinder block:

- (a) Using a screwdriver and hammer, tap out the oil seal.

- (b) Using SST and a hammer, tap in a new oil seal.

SST 09214-41010

- (c) Apply MP grease to the oil seal lip.

B. If the timing belt case is installed to the cylinder block:

- (a) Using a knife, cut off the lip of the oil seal as shown.

- (b) Using a screwdriver, pry out the oil seal.

NOTICE: Be careful not to damage the crankshaft. Tape the screwdriver tip.

- (c) Check the oil seal lip contact surface of the pump drive shaft for cracks or damage.

- (d) Apply MP grease to a new oil seal lip.

- (e) Using SST and a hammer, tap in the oil seal.

SST 09214-41010

ASSEMBLY OF PISTON AND CONNECTING ROD

(See page EM-63)

1. ASSEMBLE PISTON AND CONNECTING ROD

- (a) Install a new snap ring on one side of the piston pin hole.

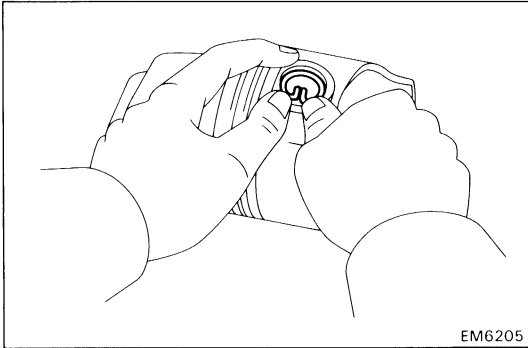

- (b) Gradually heat the piston to approx. 60°C (140°F).

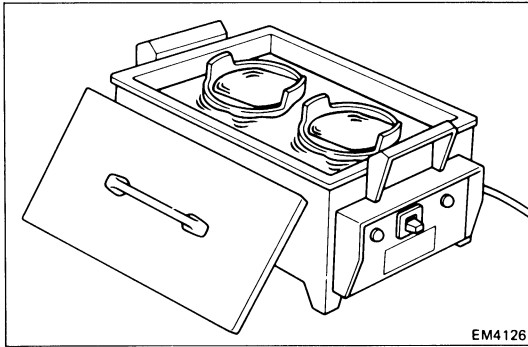

- (c) Coat the piston pin with engine oil.

- (d) Align the front marks of the piston and the connecting rod, and push in the piston pin with your thumb.

- (e) Install a new snap ring on the other side of the pin hole.

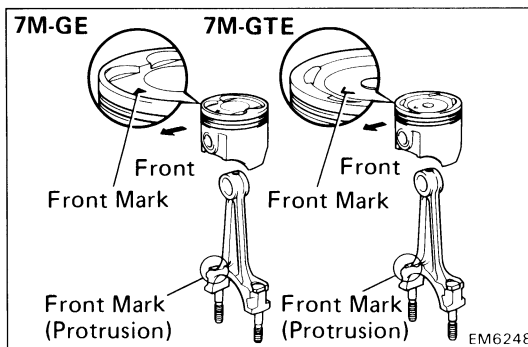
**2. INSTALL PISTON RINGS**

- (a) Install the oil ring expander and two side rails by hand.

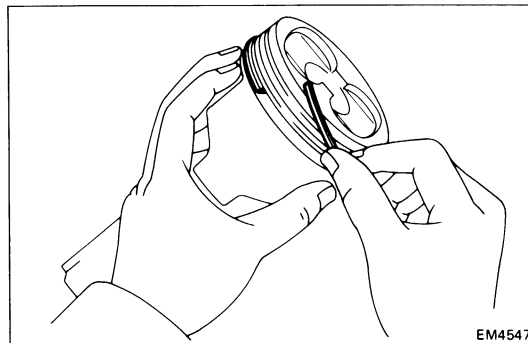

- (b) Using a piston ring expander, install the two compression rings with the code mark facing upward.

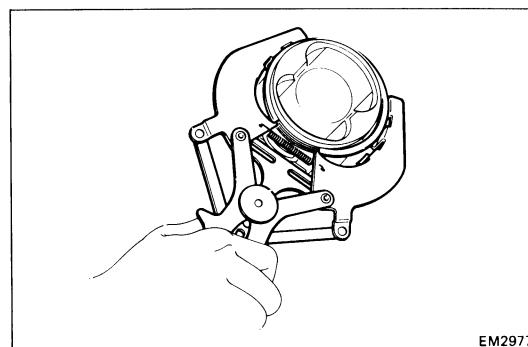

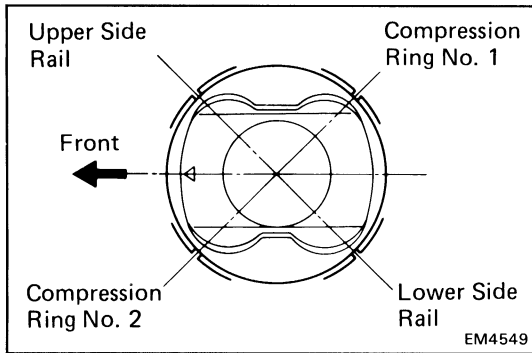

- (c) Position the piston rings so that the ring end gaps are as shown.

NOTICE: Do not align the end gaps.

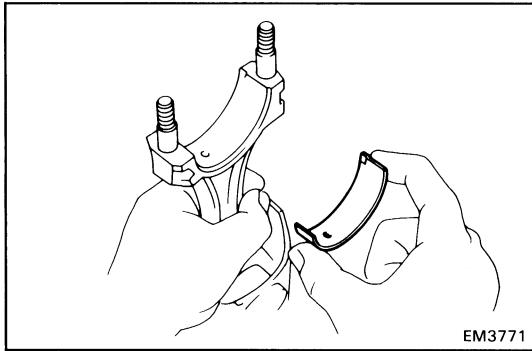

3. INSTALL BEARINGS

- (a) Align the bearing claw with the claw groove of the connecting rod or connecting rod cap.
- (b) Install the bearing in the connecting rod and rod cap.

NOTICE: Install the bearings with the oil hole in the connecting rod.

ASSEMBLY OF CYLINDER BLOCK

(See page EM-63)

HINT:

- Thoroughly clean all parts to be assembled.
- Before installing the parts, apply new engine oil to all sliding and rotating surfaces.
- Replace all gaskets, O-rings and oil seals with new parts.

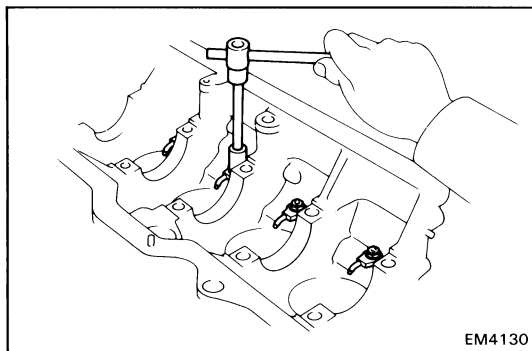

1. (7M-GTE) INSTALL OIL NOZZLES

Torque: 250 kg-cm (18 ft-lb, 25 N·m)

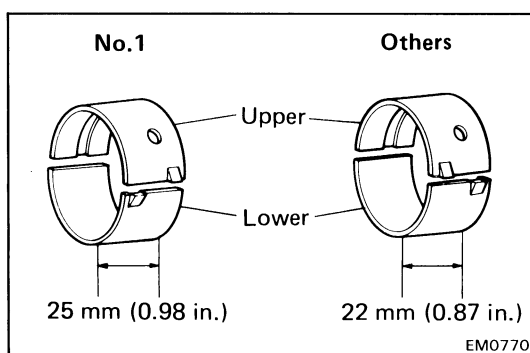

2. INSTALL MAIN BEARINGS

HINT: Different bearings are used for the No.1 and others.

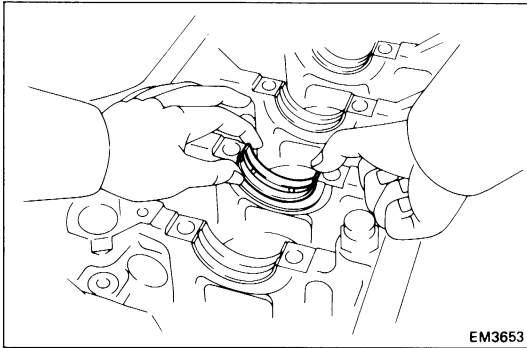

- (a) Align the bearing claw with the claw groove of the main bearing cap or cylinder block.
- (b) Install the bearing in the cylinder block and bearing caps.

NOTICE: Install the bearing with the oil hole in the block.

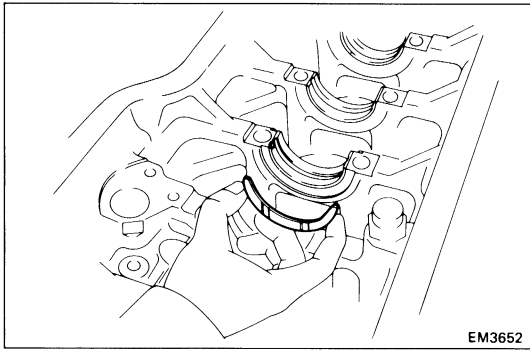

3. INSTALL UPPER THRUST WASHERS

Install the thrust washers under the No. 4 main journal position of the block with the oil grooves facing outward.

4. PLACE CRANKSHAFT ON CYLINDER BLOCK

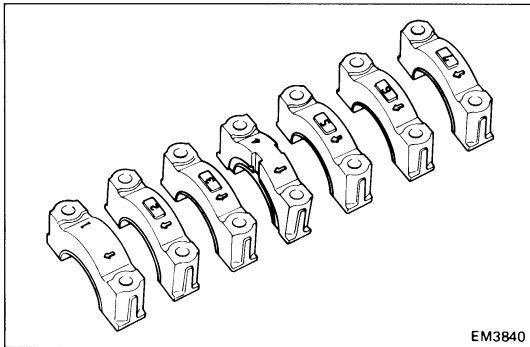

5. INSTALL MAIN BEARING CAPS AND LOWER THRUST WASHERS

HINT: Each bearing cap has a number and front mark.

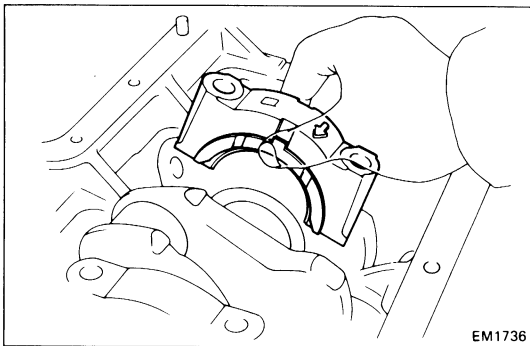

- (a) Install the thrust washers on the No. 4 bearing cap with the grooves facing outward.

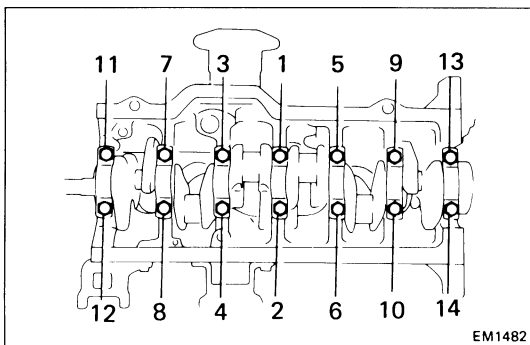

- (b) Install the bearing caps in numbered order with arrows facing forward.
- (c) Install and uniformly tighten the fourteen cap bolts in several passes, in the sequence shown.

Torque: 1,040 kg-cm (75 ft-lb, 102 N·m)

- (d) Check that the crankshaft turns smoothly.
- (e) Check the crankshaft thrust clearance.
(See step 21 on page EM-71)

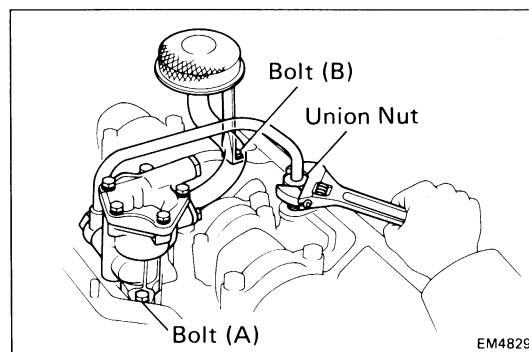
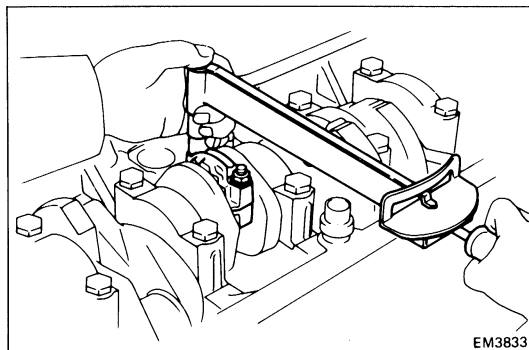
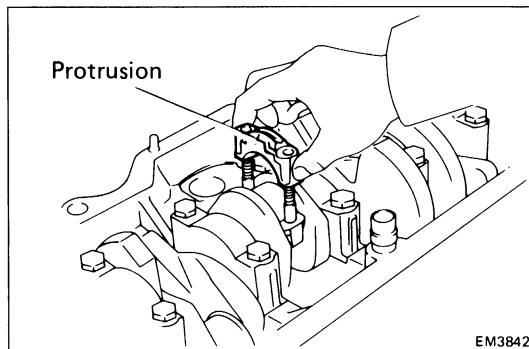
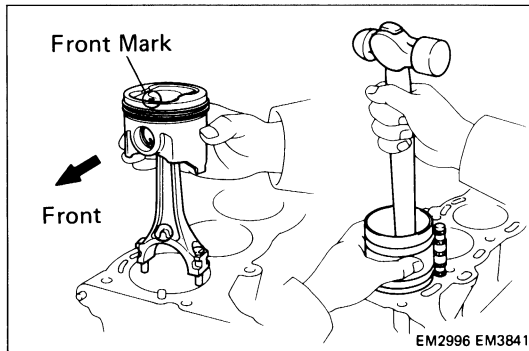
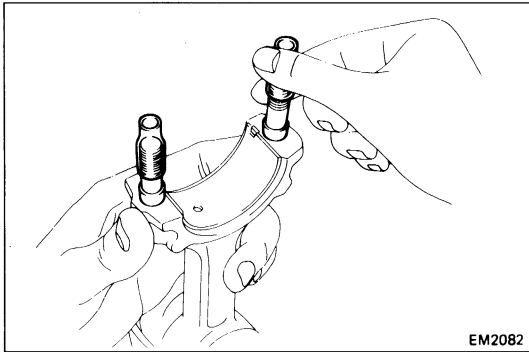

6. INSTALL PISTON AND CONNECTING ROD ASSEMBLIES

- (a) Cover the connecting rod bolts with a short piece of hose to protect the crankshaft from damage.
- (b) Using a piston ring compressor, push the correctly numbered piston and connecting rod assemblies into each cylinder with the front mark of the piston facing forward.

7. INSTALL CONNECTING ROD CAPS

- (a) Match the numbered cap with the numbered connecting rod.
- (b) Install the cap with the protrusion facing forward.

- (c) Apply a light coat of engine oil on the threads and under the nuts of the connecting rod cap.
- (d) Install and alternately tighten the cap nuts in several passes.

Torque: 650 kg-cm (47 ft-lb, 64 N·m)

- (e) Check that the crankshaft turns smoothly.
- (f) Check the connecting rod thrust clearance. (See step 18 on page EM-68)

8. INSTALL OIL PUMP ASSEMBLY

- (a) Clean the oil pump.
- (b) Install the oil pump with the two bolts and union nut.
Torque the bolt and union nut.

Torque: Bolt (A) 220 kg-cm (16 ft-lb, 22 N·m)
Bolt (B) 60 kg-cm (52 in.-lb, 5.9 N·m)
Union nut 350 kg-cm (25 ft-lb, 34 N·m)

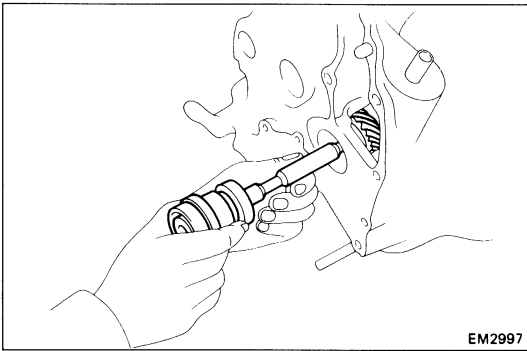

EM2997

9. INSTALL OIL PUMP DRIVE SHAFT

- (a) While turning the drive shaft, insert slowly to avoid damaging the drive shaft bearing.

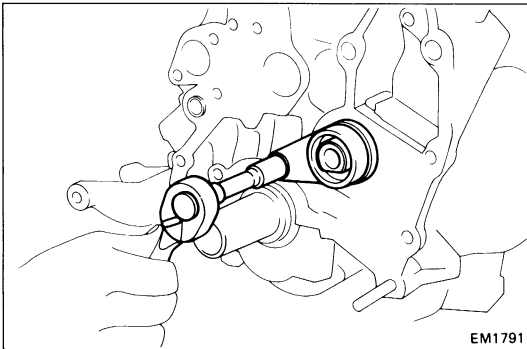

EM1791

- (b) Install the bolt.

Torque: 130 kg-cm (9 ft-lb, 13 N·m)

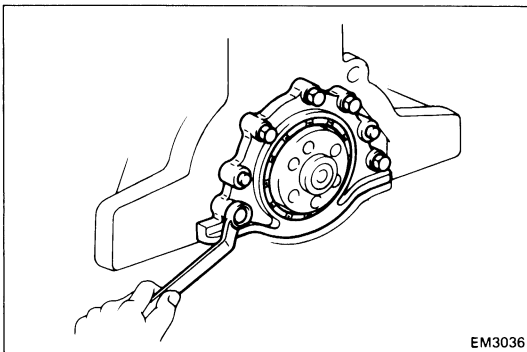

EM3036

10. INSTALL REAR OIL SEAL RETAINER

Install a new gasket and rear oil seal retainer with the five bolts.

Torque: 130 kg-cm (9 ft-lb, 13 N·m)

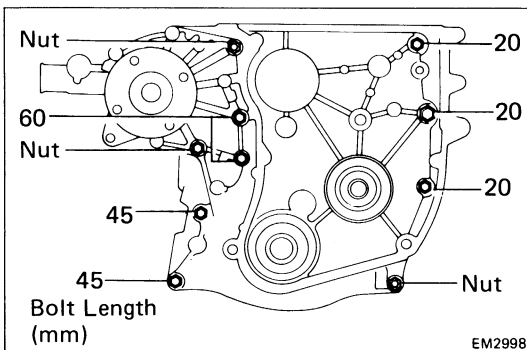

EM2998

11. INSTALL TIMING BELT CASE WITH WATER PUMP

- (a) Position new gaskets on the cylinder block.
 (b) Apply sealant to two or three threads of the 10 mm bolt end.

Sealant: Part No. 08833-00070, THREE BOND 1324 or equivalent

- (c) Install the timing belt case with the seven bolts and three nuts.

Torque:

12 mm head bolt and nut

195 kg-cm (14 ft-lb, 19 N·m)

14 mm head bolt

400 kg-cm (29 ft-lb, 39 N·m)

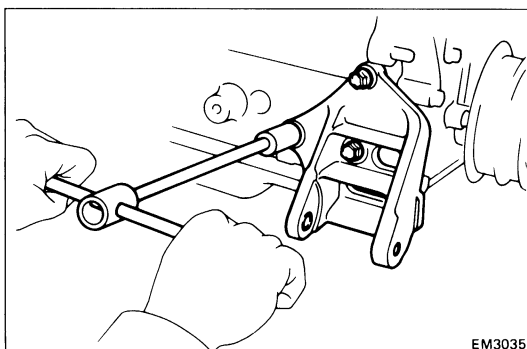

EM3035

12. INSTALL OIL PAN

(See page LU-12)

13. INSTALL PS PUMP BRACKET

14. INSTALL OIL HOLE COVER PLATE

Install a new gasket and oil hole cover plate with the two bolts.

**15. (7M-GE)
INSTALL NEW OIL FILTER
(See page LU-5)**

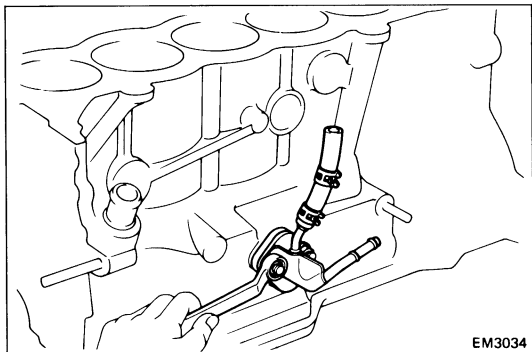
16. INSTALL ENGINE MOUNTING BRACKETS**17. INSTALL FUEL RETURN PIPE SUPPORT**

Install a new insulator and fuel pipe support with the two nuts.

Torque: 130 kg-cm (89 ft-lb, 13 N·m)

**18. (7M-GE)
INSTALL VACUUM CONTROL VALVE SET**

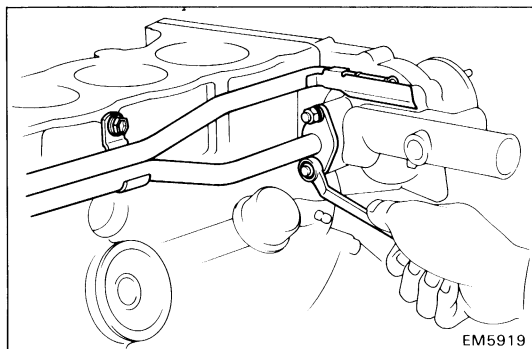
19. INSTALL GROUND STRAP TO CYLINDER BLOCK**20. INSTALL WATER BY-PASS PIPE**

(a) Install a new gasket and water by-pass pipe to the timing belt case with the two nuts.

Torque: 140 kg-cm (10 ft-lb, 14 N·m)

(b) Install the water by-pass pipe to the cylinder block with the three bolts.

Torque: 130 kg-cm (9 ft-lb, 13 N·m)

21. INSTALL CYLINDER HEAD

(See steps 1 and 4 to 16 and 18 on pages EM-55 to 61)

22. INSTALL TIMING BELT

(See steps 1 to 8, 10 to 12 and 16 on pages EM-28 to 31)

23. REMOVE ENGINE STAND**24. INSTALL REAR END PLATE**

Torque: 130 kg-cm (9 ft-lb, 13 N·m)

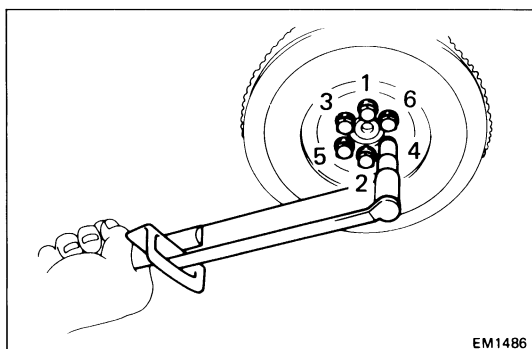
**25. INSTALL FLYWHEEL OR DRIVE PLATE ON CRANKSHAFT**

(a) Install the flywheel or drive plate on crankshaft.

(b) Apply a light coat of engine oil on the threads and under the bolt heads.

(c) Install and uniformly tighten the bolts in several passes, in the sequence shown.

Torque: 750 kg-cm (54 ft-lb, 74 N·m)

INSTALLATION OF ENGINE

1. (7M-GE)
INSTALL CLUTCH DISC AND COVER
(See page CL-15)
2. **INSTALL TRANSMISSION TO ENGINE**
3. (A/T)
INSTALL A/T OIL COOLER PIPES
4. **INSTALL ENGINE WITH TRANSMISSION IN VEHICLE**
 - (a) Attach the engine hoist chain to the engine hangers.
 - (b) Lower the engine into the engine compartment.
 - (c) Align the engine with the transmission and engine mounting supports.
 - (d) Install the engine mounting washers and nuts on each side of the engine.
 - (e) Remove the hoist chain.
5. **RAISE VEHICLE**
6. **INSTALL ENGINE REAR SUPPORT MEMBER WITH GROUND STRAP TO BODY**
7. **INSTALL FRONT CROSS MEMBER**
8. (M/T)
INSTALL CLUTCH RELEASE CYLINDER
9. (A/T)
INSTALL MANUAL SHIFT LINKAGE
(See page AT-19)
10. **CONNECT SPEEDOMETER CABLE**
11. **INSTALL PROPELLER SHAFT**
(See page PR-9)
12. **INSTALL EXHAUST PIPE**
13. **CONNECT FUEL HOSES**
14. (7M-GTE)
INSTALL ENGINE MOUNTING ABSORBER
15. **CONNECT GROUND STRAP TO FUEL HOSE CLAMP**
16. (M/T)
INSTALL SHIFT LEVER
17. **CONNECT ENGINE OIL COOLER HOSES**
18. **INSTALL PS PUMP**
19. (7M-GTE)
INSTALL NO.6 AIR CLEANER HOSE
20. **INSTALL A/C COMPRESSOR**
21. **CONNECT HEATER HOSES**

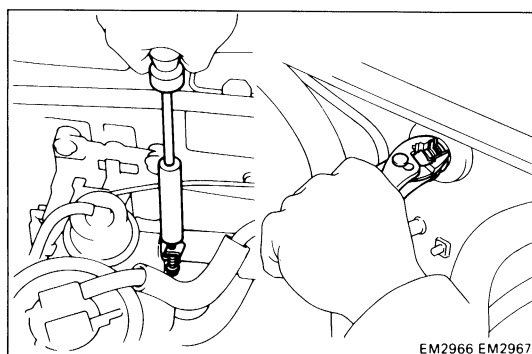

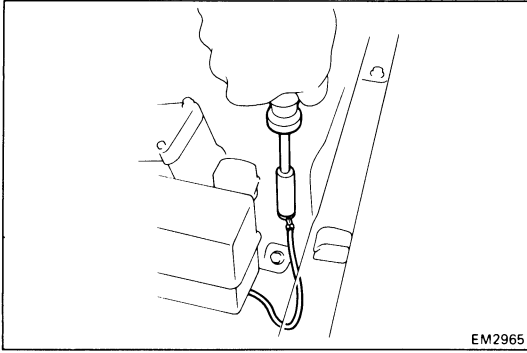
**22. CONNECT FOLLOWING CONNECTORS AND WIRES:**

- (a) ECU and ECT connectors
- (b) Ground strap to engine rear side
- (c) Heater valve connector
- (d) (7M-GE)
Oxygen sensor connector
- (e) Alternator connector and wire
- (f) Main relay connector
- (g) (7M-GE)
Ignition coil connector
(7M-GTE)
Igniter connector
- (h) (7M-GTE)
Solenoid resistor connector
- (i) Check connector
- (j) Theft deterrent horn connector
- (k) Noise filter connector
- (l) Battery positive cable to battery
- (m) Ground strap to LH front fender apron

23. CONNECT FOLLOWING HOSES:

- (a) Charcoal canister hose
- (b) Cruise control hose
- (c) Heater valve hose
- (d) Brake booster hose

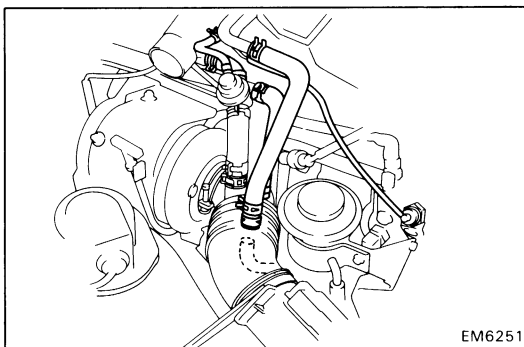
**24. INSTALL PS BELT
(See page MA-4)****25. INSTALL ALTERNATOR DRIVE BELT, WATER PUMP PULLEY AND FLUID COUPLING
(See page CO-7)****26. INSTALL A/C BELT
(See page MA-4)****27. INSTALL RADIATOR
(See page CO-14)****28. (7M-GTE)
INSTALL NO.7 AIR CLEANER HOSE WITH AIR FLOW METER AND AIR CLEANER CAP**

- (a) Connect the PS air hose.
- (b) Connect the air flow meter connector.
- (c) Connect the three air hose and PCV hose.

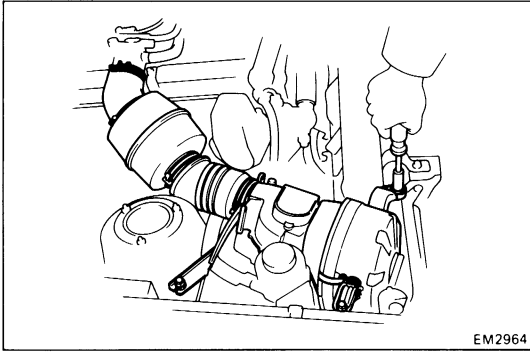
**29. (7M-GE)****INSTALL AIR CLEANER CASE WITH HOSES**

- (a) Install the air cleaner case with hoses with the three bolts.
- (b) Connect the PS air hose.
- (c) Connect the air flow meter connector.

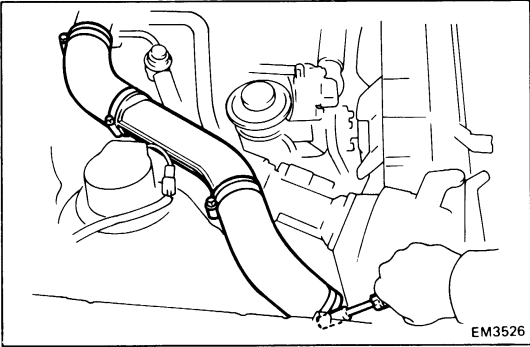
**30. (7M-GTE)****INSTALL NO. 4 AIR CLEANER PIPE WITH NO. 1 AND NO. 2 AIR CLEANER HOSES****31. FILL WITH ENGINE OIL**

(See page LU-6)

32. FILL WITH COOLANT

(See page CO-5)

33. INSTALL HOOD**34. CONNECT CABLE TO NEGATIVE TERMINAL OF BATTERY****35. START ENGINE**

Warm up the engine and inspect for leaks.

36. INSTALL ENGINE UNDER COVER**37. PERFORM ENGINE ADJUSTMENT**

Recheck the ignition timing.
(See page IG-20)

38. ROAD TEST

Road test vehicle.

39. RECHECK COOLANT AND ENGINE OIL LEVELS

