

CLUTCH

	Page
TROUBLESHOOTING	CL-2
CHECK AND ADJUSTMENT OF CLUTCH PEDAL	CL-3
BLEEDING OF CLUTCH SYSTEM	CL-4
INSPECTION OF CLUTCH START SYSTEM	CL-4
CLUTCH MASTER CYLINDER	CL-6
CLUTCH RELEASE CYLINDER	CL-8
CLUTCH UNIT	CL-11

TROUBLESHOOTING

Problem	Possible cause	Remedy	Page
Hard to shift or will not shift	Clutch pedal freeplay excessive	Adjust pedal freeplay	CL-3
	Air in clutch lines	Bleed clutch system	CL-4
	Clutch release cylinder faulty	Repair release cylinder	CL-8
	Clutch master cylinder faulty	Repair master cylinder	CL-6
	Clutch disc out of true, runout is excessive or lining broken	Inspect clutch disc	CL-11
	Splines on input shaft or clutch disc dirty or burred	Repair as necessary	CL-11
	Clutch pressure plate faulty	Replace clutch cover	CL-11
Transmission jumps out of gear	Clutch pilot bearing worn	Replace pilot bearing	CL-11
Clutch slips	Clutch pedal freeplay insufficient	Adjust pedal freeplay	CL-3
	Clutch disc lining oily or worn out	Inspect clutch disc	CL-11
	Pressure plate faulty	Replace clutch cover	CL-11
	Release fork binding	Inspect release fork	CL-11
Clutch grabs/ chatters	Clutch disc lining oily or worn out	Inspect clutch disc	CL-11
	Pressure plate faulty	Replace clutch cover	CL-11
	Clutch diaphragm spring bent	Align clutch diaphragm	CL-11
	Engine mounts loose	Repair as necessary	
Clutch pedal spongy	Air in clutch lines	Bleed clutch system	CL-4
	Clutch release cylinder faulty	Repair release cylinder	CL-8
	Clutch master cylinder faulty	Repair master cylinder	CL-6
Clutch noisy	Loose part inside housing	Repair as necessary	
	Release bearing worn or dirty	Replace release bearing	CL-11
	Pilot bearing worn	Replace pilot bearing	CL-11

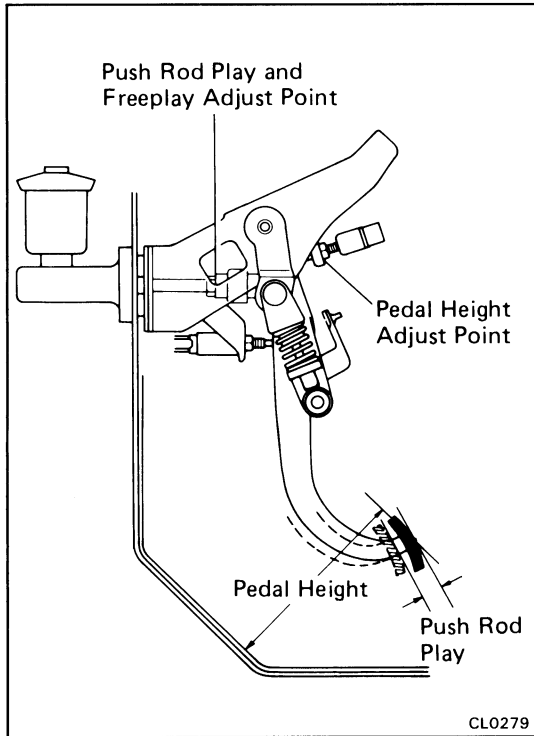

CHECK AND ADJUSTMENT OF CLUTCH PEDAL

1. CHECK THAT PEDAL HEIGHT IS CORRECT

Pedal height from asphalt sheet: 157 — 167 mm
(6.18 — 6.57 in.)

2. IF NECESSARY, ADJUST PEDAL HEIGHT

- Loosen the lock nut and turn the adjusting bolt until the height is correct.
- Tighten the lock nut.
- After adjusting the pedal height, check the pedal freeplay.

3. CHECK THAT PEDAL FREEPLAY IS CORRECT AS SPECIFIED

Push in on the pedal until the beginning of clutch resistance is felt.

Pedal freeplay: 5 — 15 mm (0.20 — 0.59 in.)

Push rod play at pedal: 1 — 5 mm (0.04 — 0.20 in.)

4. IF NECESSARY, ADJUST PEDAL FREEPLAY

- Loosen the lock nut and turn the push rod until the freeplay is correct.
- Tighten the lock nut.
- After adjusting the pedal freeplay, check the pedal height.

5. CHECK PEDAL OPERATION

While gently depressing the pedal, check that engagement and disengagement are smooth.

6. INSPECT CLUTCH RELEASE POINT

- Pull the parking brake lever and install wheel stopper.
- Start the engine and idle the engine.
- Without depressing the clutch pedal, slowly shift the shift lever into reverse position until the gears contact.
- Gradually depress the clutch pedal and measure the stroke distance from the point the gear noise stops (release point) up to the full stroke end position.

Standard distance: 25 mm (0.98 in.) or more
(From pedal stroke end position to release point)

If clearance is not as specified, perform the following operation.

- Inspect pedal height.
- Inspect push rod play and pedal free play.
- Bleed the clutch line.
- Inspect the clutch cover and disc.

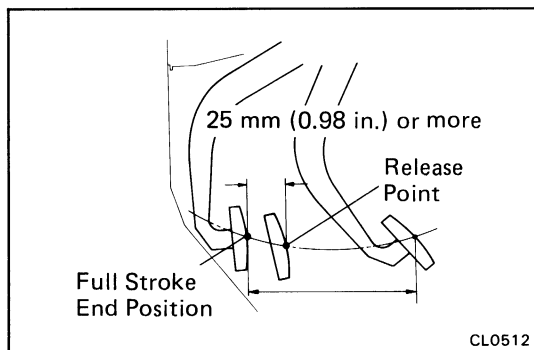

BLEEDING OF CLUTCH SYSTEM

HINT: If any work is done on the clutch system or if air is suspected in the clutch lines, bleed the system of air.

NOTICE: Do not let brake fluid remain on a painted surface. Wash it off immediately.

1. FILL CLUTCH RESERVOIR WITH BRAKE FLUID

Check the reservoir frequently. Add fluid if necessary.

2. CONNECT VINYL TUBE TO BLEEDER PLUG

Insert the other end of the tube in a half-full container of brake fluid.

3. BLEED CLUTCH LINE

- (a) Slowly pump the clutch pedal several times.
- (b) While depressing the pedal, loosen the bleeder plug until the fluid starts to run out. Then close the bleeder plug.
- (c) Repeat this procedure until there are no bubbles in the fluid.

HINT: Do not reuse the fluid that was bled. It contains air.

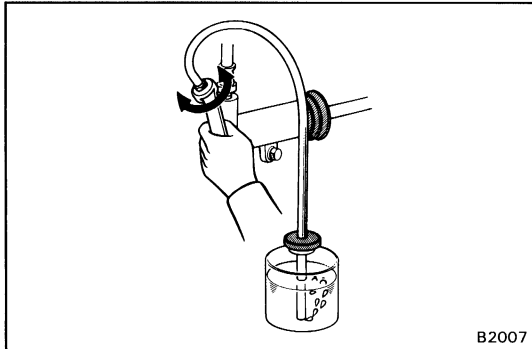

INSPECTION OF CLUTCH START SYSTEM

CHECK CLUTCH PEDAL

1. CHECK THAT PEDAL HEIGHT IS CORRECT
(See page CL-3)
2. CHECK THAT PEDAL FREEPLAY AND PUSH ROD PLAY ARE CORRECT
(See page CL-3)

CHECK CLUTCH START SYSTEM

CHECK CLUTCH START SYSTEM

- (a) Check that the engine does not start when the clutch pedal is released.
- (b) Check that the engine starts when the clutch pedal is fully depressed.
- (c) Check that clearance "A" is greater than 1 mm (0.04 in.) when the clutch pedal is fully depressed.

If necessary, adjust or replace the clutch start switch.

INSPECTION AND ADJUSTMENT OF CLUTCH START SWITCH

1. INSPECT CONTINUITY OF CLUTCH START SWITCH

- (a) Check that there is continuity between terminals when the switch is ON (pushed).
- (b) Check that there is no continuity between terminals when the switch is OFF (free).

If continuity is not as specified, replace the switch.

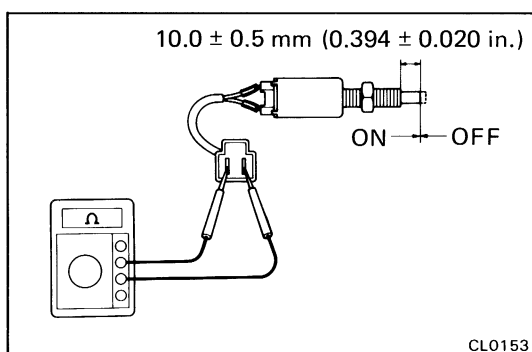
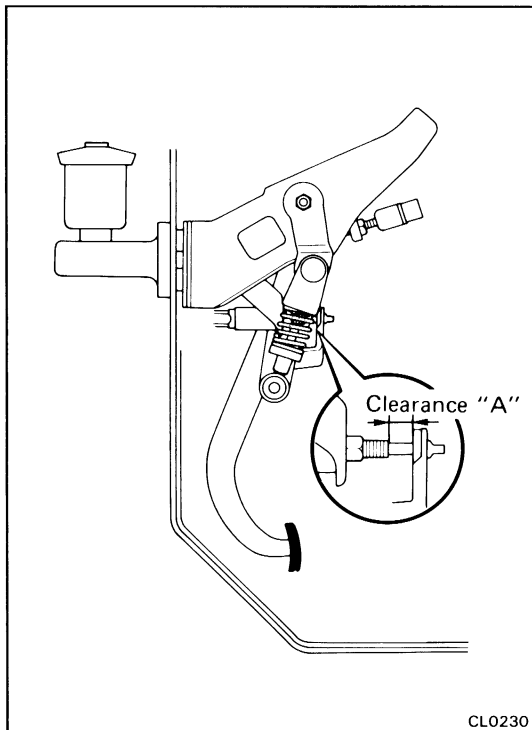

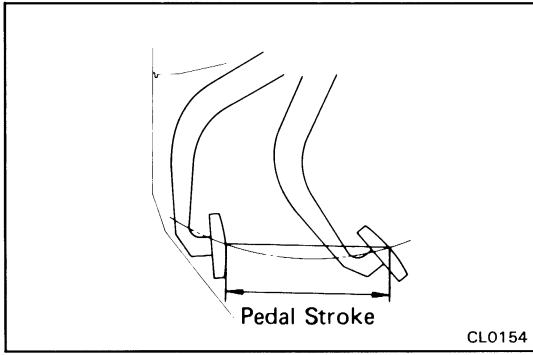

2. ADJUST CLUTCH START SWITCH

- (a) Measure the pedal stroke, and check the switch clearance "A" using the chart left.
- (b) Loosen and adjust the switch position.

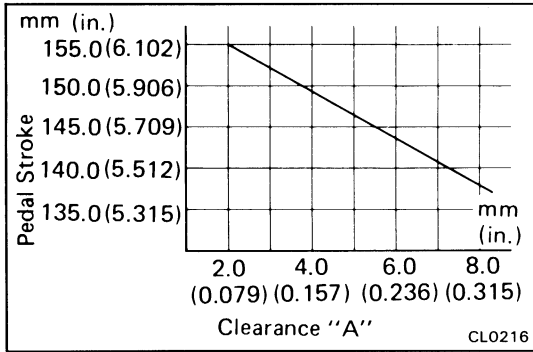

- (c) Recheck that the engine does not start when the clutch pedal is released.

CLUTCH MASTER CYLINDER COMPONENTS

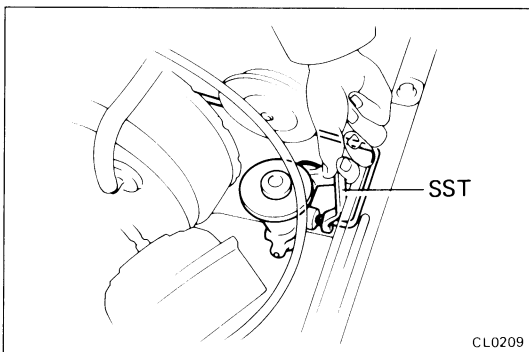
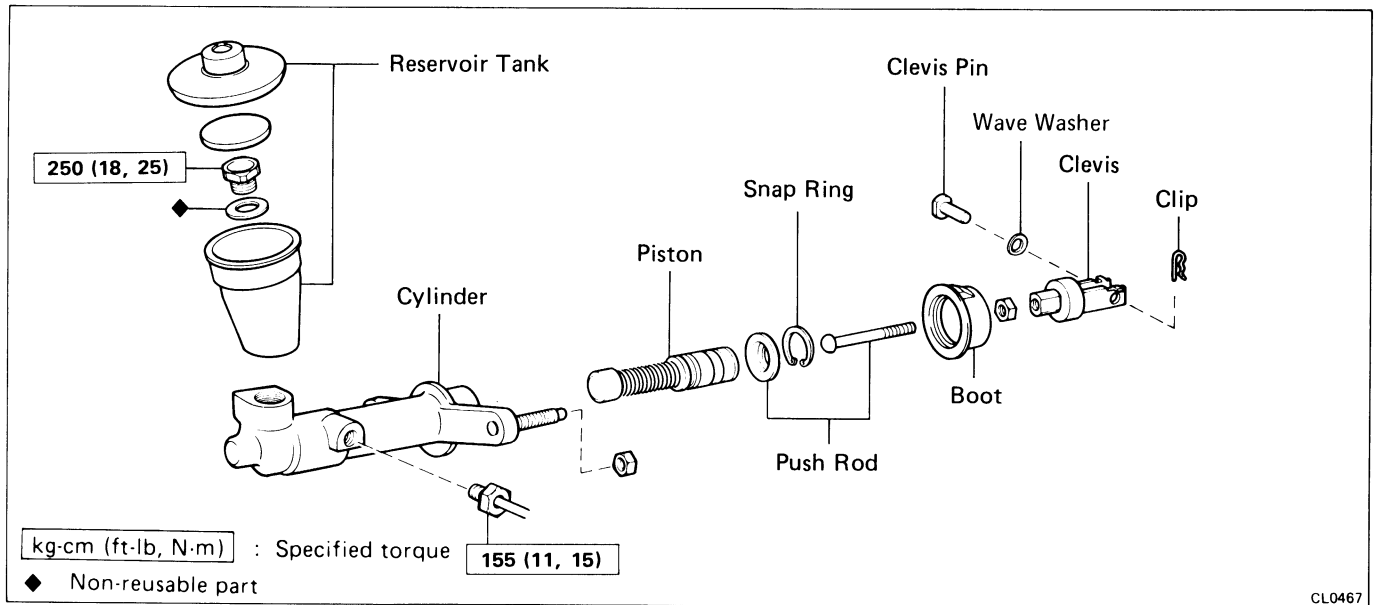

REMOVAL OF MASTER CYLINDER

- DRAW OUT FLUID WITH SYRINGE**
- DISCONNECT CLUTCH LINE UNION**
Using SST, disconnect the union nut.
SST 09751-36011
- REMOVE INSTRUMENT LOWER FINISH PANEL AND AIR DUCT**
- REMOVE CLIP, CLEVIS PIN AND SPRING WASHER**
- REMOVE MOUNTING NUTS AND PULL OUT MASTER CYLINDER**

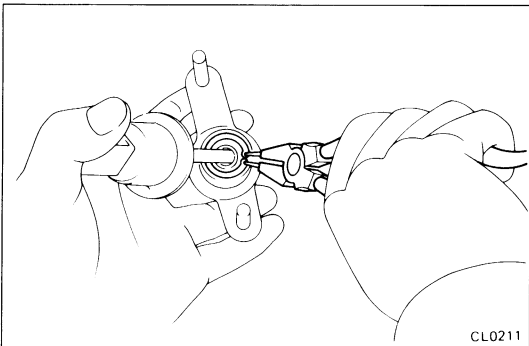

DISASSEMBLY OF MASTER CYLINDER

- REMOVE RESERVOIR TANK**
Remove the hold-down bolt and pull off the reservoir tank.
- REMOVE PUSH ROD**
 - Pull back the boot, and using a screwdriver, remove the snap ring.
 - Pull out the push rod assembly.
- REMOVE PISTON**
Using compressed air, remove the piston from the cylinder.

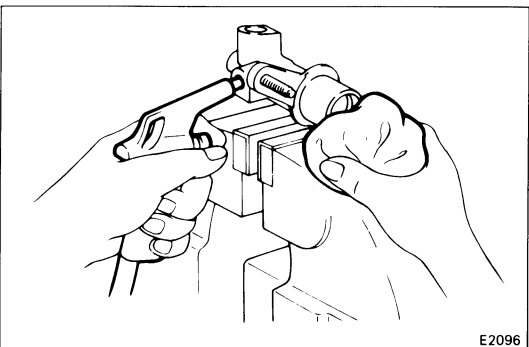

INSPECTION OF MASTER CYLINDER

HINT: Clean the disassembled parts with compressed air.

1. INSPECT MASTER CYLINDER BORE FOR SCORING OR CORROSION

If a problem is found, clean or replace the cylinder.

2. INSPECT PISTON AND CUPS FOR WEAR, SCORING, CRACKS OR SWELLING

If either one requires replacement, use the parts from the cylinder kit.

3. INSPECT PUSH ROD FOR WEAR OR DAMAGE

If necessary, replace the push rod.

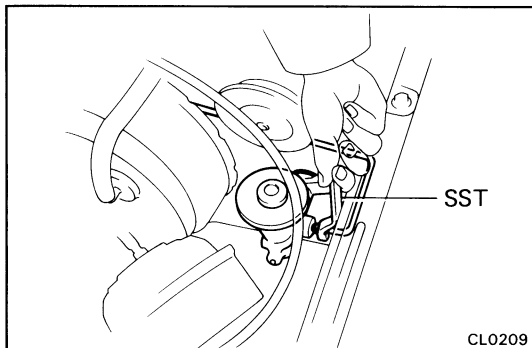
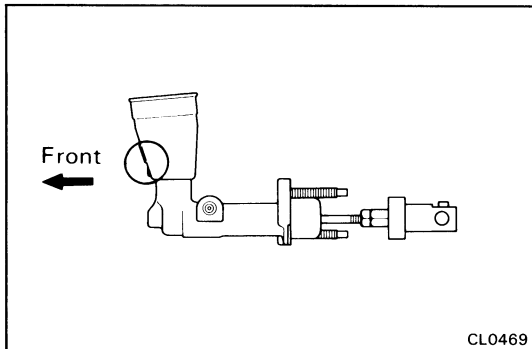
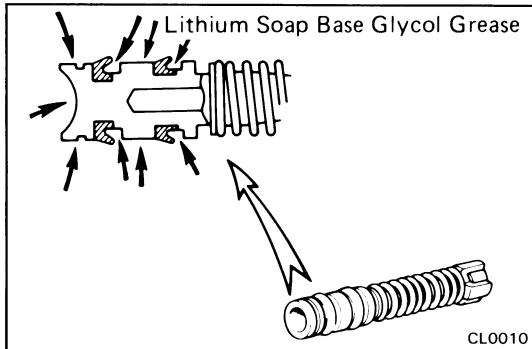
**ASSEMBLY OF MASTER CYLINDER**

(See page CL-6)

1. COAT PARTS WITH LITHIUM SOAP BASE GLYCOL GREASE, AS SHOWN

2. INSERT PISTON INTO CYLINDER

3. INSTALL PUSH ROD ASSEMBLY WITH SNAP RING

4. INSTALL RESERVOIR TANK

Torque: 250 kg-cm (18 ft-lb, 25 N·m)

INSTALLATION OF MASTER CYLINDER

(See page CL-6)

1. POSITION MASTER CYLINDER AND CONNECT CLUTCH LINE UNION

First finger-tighten the union nut and then tighten it to specified torque with SST.

SST 09751-36011

Torque: 155 kg-cm (11 ft-lb, 15 N·m)

2. INSTALL AND TIGHTEN MOUNTING NUTS

3. INSTALL PUSH ROD ASSEMBLY TO CLUTCH PEDAL

Secure the clevis pin with the spring washer and clip.

4. BLEED CLUTCH SYSTEM

(See page CL-4)

5. CHECK FOR LEAKS

6. CHECK AND ADJUST CLUTCH PEDAL

(See page CL-3)

7. INSTALL INSTRUMENT LOWER FINISH PANEL AND AIR DUCT

CLUTCH RELEASE CYLINDER COMPONENTS

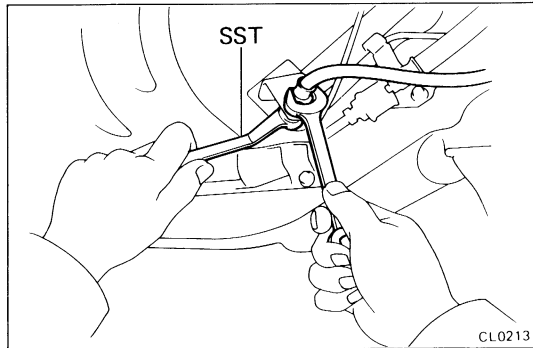
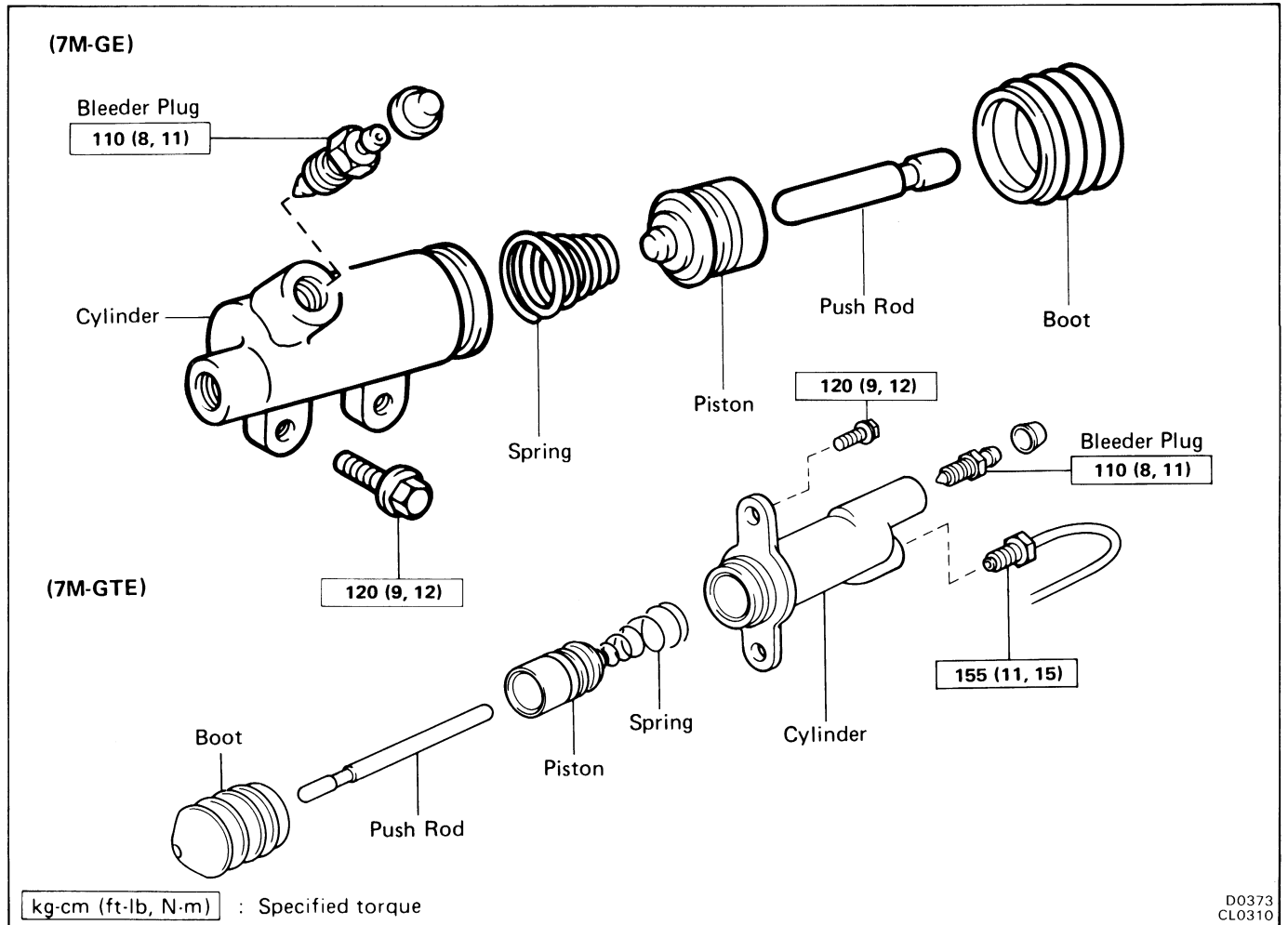

REMOVAL OF RELEASE CYLINDER

(7M-GE)

1. REMOVE FLEXIBLE HOSE

(a) Using SST, disconnect the union.

SST 09751-36011

(b) Remove the flexible hose from the release cylinder.

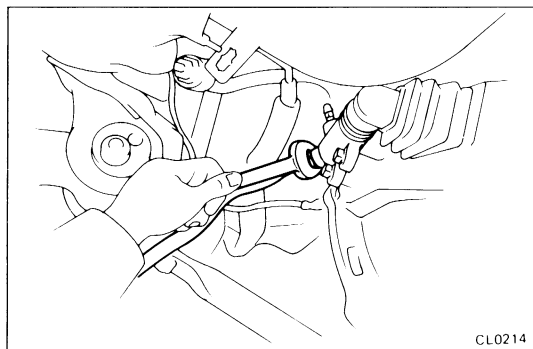

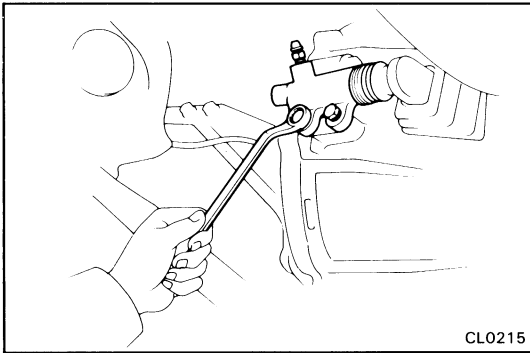

CL0215

2. REMOVE RELEASE CYLINDER

Remove the two bolts and pull out the release cylinder.

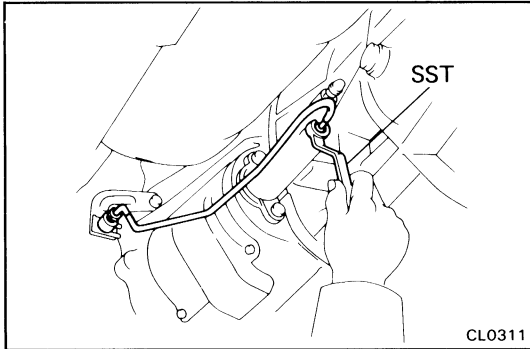

CL0311

(7M-GTE)

1. REMOVE CLUTCH LINE TUBE

Using SST, disconnect the two union nuts and remove the clutch line tube.

SST 09751-36011

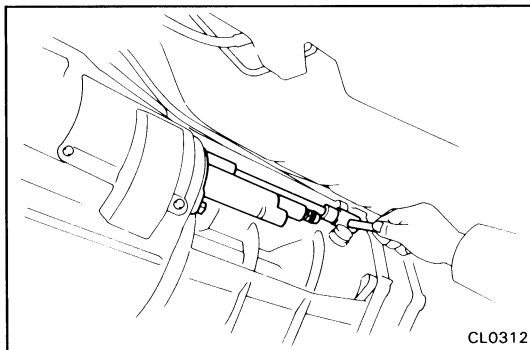

CL0312

2. REMOVE RELEASE CYLINDER

Remove the two bolts and pull out the release cylinder.

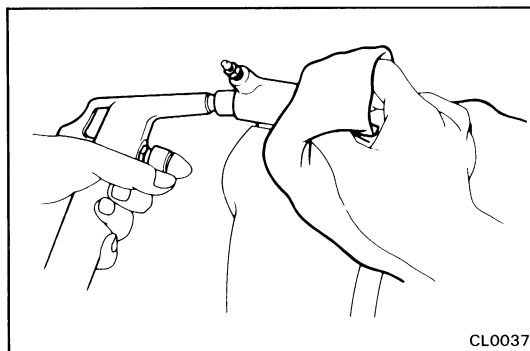

CL0037

DISASSEMBLY OF RELEASE CYLINDER

(See page CL-8)

1. PULL OUT PUSH ROD WITH BOOT

2. REMOVE PISTON WITH SPRING

Using compressed air, remove the piston with spring.

INSPECTION OF RELEASE CYLINDER

HINT: Clean the disassembled parts with compressed air.

1. INSPECT RELEASE CYLINDER BORE FOR SCORING OR CORROSION

If a problem is found, clean or replace the cylinder.

2. INSPECT PISTON AND CUPS FOR WEAR, SCORING, CRACKS OR SWELLING

If either one requires replacement, use the parts from the cylinder kit.

3. INSPECT PUSH ROD FOR WEAR OR DAMAGE

If necessary, replace the push rod.

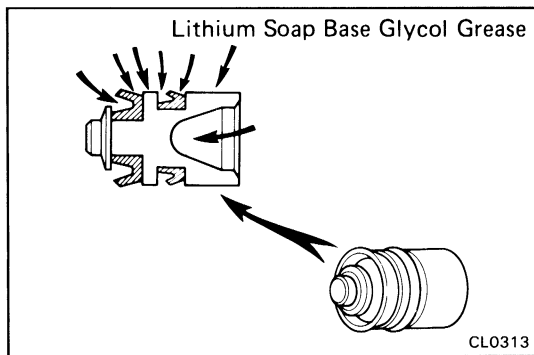
**ASSEMBLY OF RELEASE CYLINDER**

(See page CL-8)

1. COAT PISTON WITH LITHIUM SOAP BASE GLYCOL GREASE, AS SHOWN
2. INSERT PISTON WITH SPRING INTO CYLINDER
3. INSTALL PUSH ROD WITH BOOT

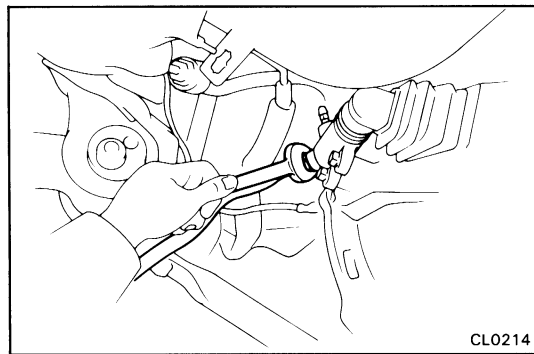
**INSTALLATION OF CLUTCH RELEASE CYLINDER**

(7M-GE)

1. INSTALL RELEASE CYLINDER WITH TWO BOLTS

Torque: 120 kg-cm (9 ft-lb, 12 N·m)

2. INSTALL FLEXIBLE HOSE

(a) Install and torque the flexible hose to the release cylinder.

Torque: 235 kg-cm (17 ft-lb, 23 N·m)

(b) Using SST, connect and torque the clutch line union to the flexible hose.

HINT: First, finger-tighten and then tighten to specified torque.

SST 09751-36011

Torque: 155 kg-cm (11 ft-lb, 15 N·m)

(c) Install the clip.

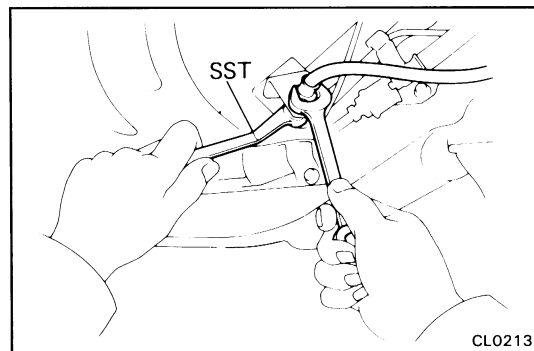

3. BLEED CLUTCH SYSTEM

(See page CL-4)

4. CHECK FOR LEAKS

(7M-GTE)

1. INSTALL RELEASE CYLINDER WITH TWO BOLTS

Torque: 120 kg-cmn (9 ft-lb, 12 N·m)

2. INSTALL CLUTCH LINE TUBE

Using SST, connect the clutch line tube.

HINT: First finger-tighten the union nut and then tighten it to specified torque.

SST 09751-36011

Torque: 155 kg-cm (11 ft-lb, 15 N·m)

3. BLEED CLUTCH SYSTEM

(See page CL-4)

4. CHECK FOR LEAKS

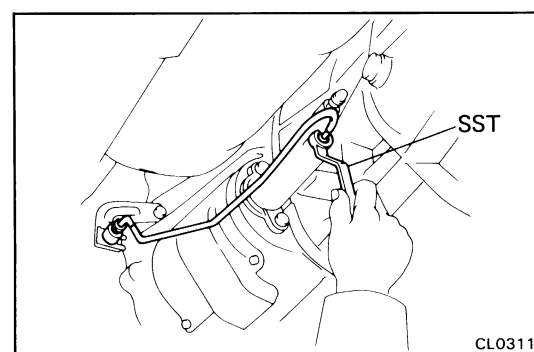
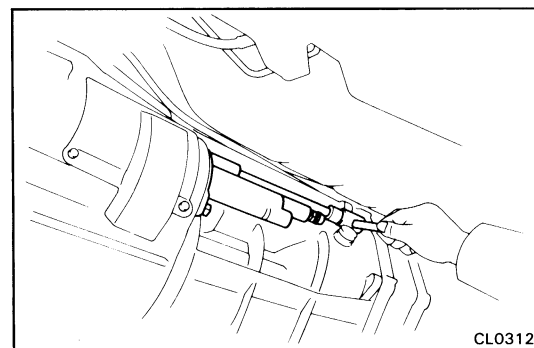

CLUTCH UNIT

COMPONENTS

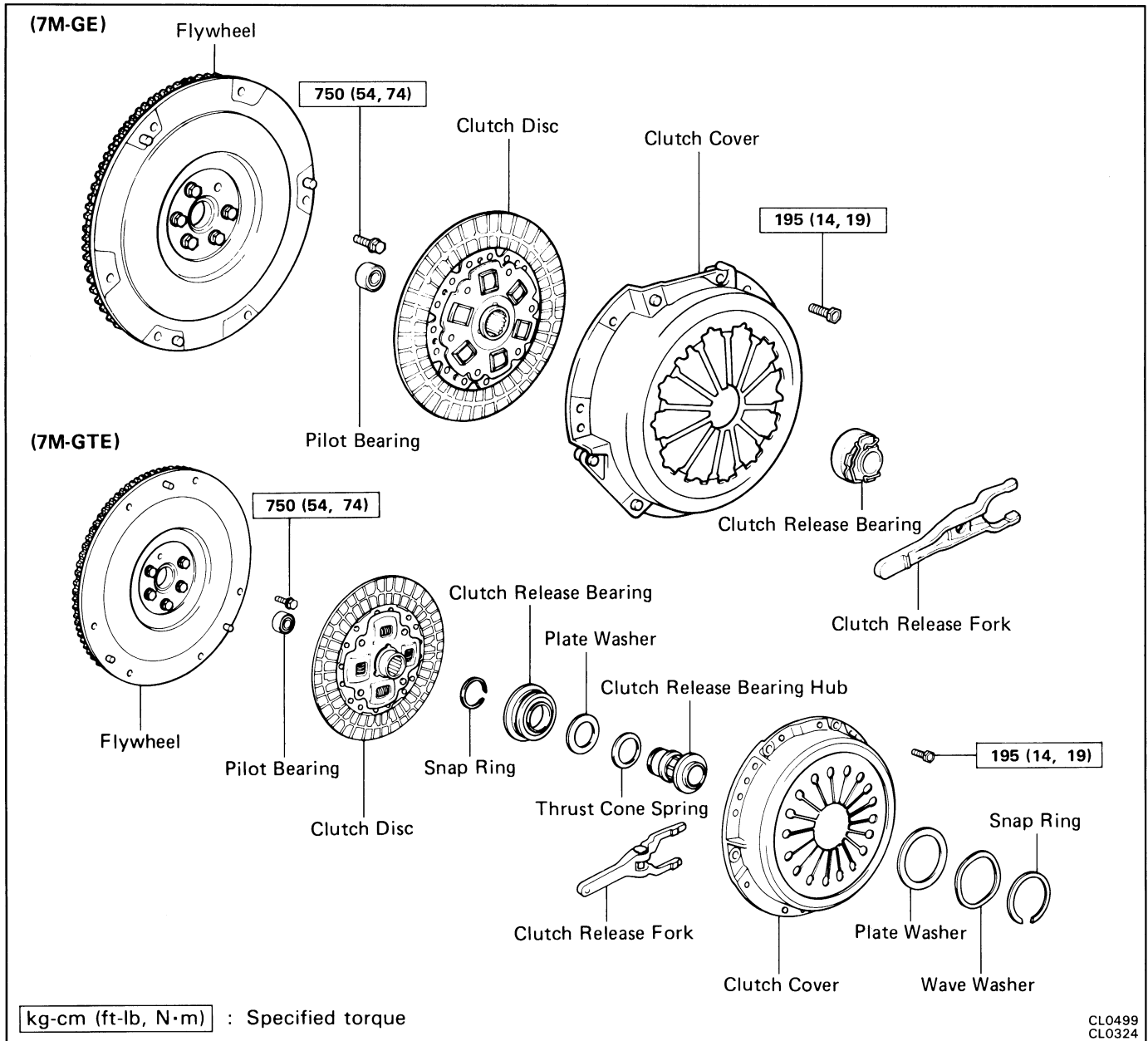

REMOVAL OF CLUTCH UNIT

(7M-GE)

1. REMOVE TRANSMISSION
(See page MT-4)

HINT: Do not drain the transmission oil.

2. REMOVE CLUTCH COVER AND DISC

- (a) Place the matchmarks on the clutch cover and flywheel.
- (b) Loosen each set bolt one turn at a time until spring tension is released.
- (c) Remove the set bolts and pull off the clutch cover and disc.

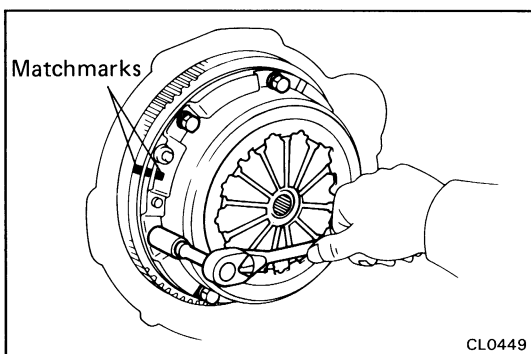

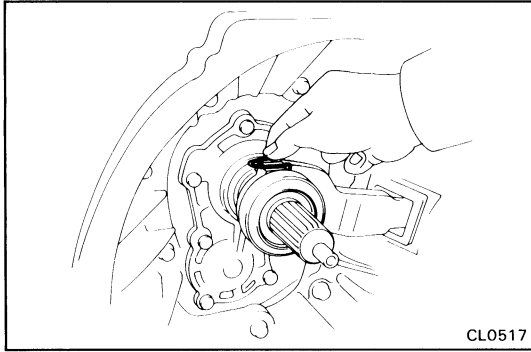

3. REMOVE RELEASE BEARING, FORK AND BOOT FROM TRANSMISSION

- (a) Remove the clips, and pull off the bearing and hub.
- (b) Remove the fork and boot.

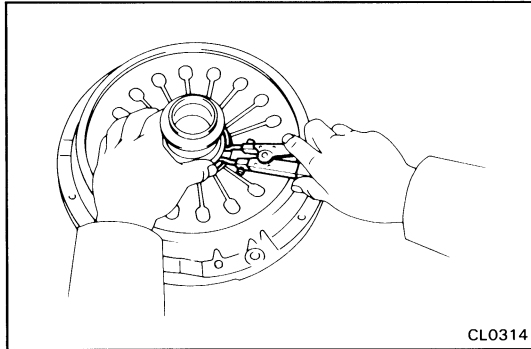

(7M-GTE)

1. REMOVE TRANSMISSION WITH CLUTCH COVER AND DISC (See page MT-3)

2. REMOVE RELEASE BEARING HUB ASSEMBLY FROM CLUTCH COVER

- (a) Using snap ring pliers, remove the snap ring.
- (b) Remove the bearing hub assembly, wave washer and plate washer.

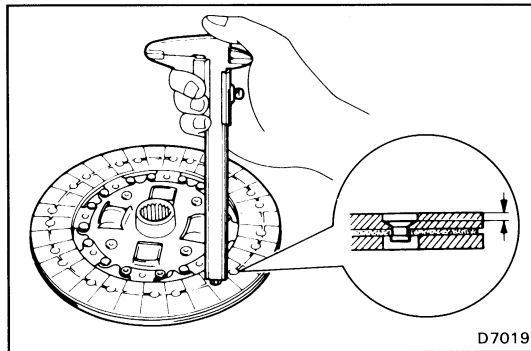

INSPECTION OF CLUTCH PARTS

1. INSPECT CLUTCH DISC FOR WEAR OR DAMAGE

Using calipers, measure the rivet head depth.

Minimum rivet depth: 0.3 mm (0.012 in.)

If a problem is found, replace the clutch disc.

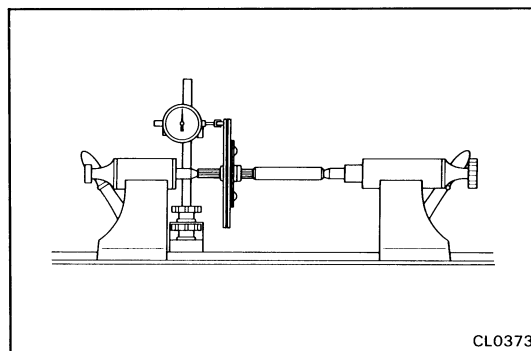

2. INSPECT CLUTCH DISC RUNOUT

Using a dial indicator, check the disc runout.

Maximum runout: 0.8 mm (0.031 in.)

If runout is excessive, replace the disc.

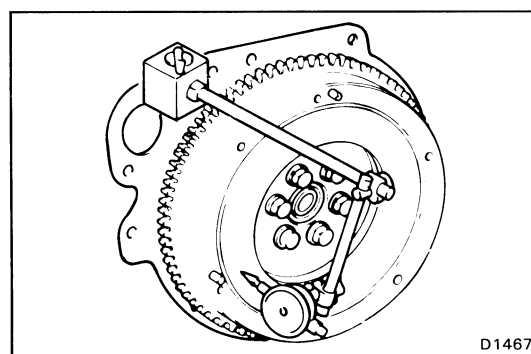

3. INSPECT FLYWHEEL RUNOUT

Using a dial indicator, check the flywheel runout.

Maximum runout: 0.2 mm (0.008 in.)

If runout is excessive, replace the flywheel.

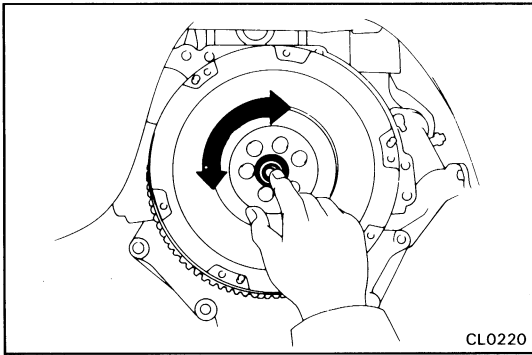

4. INSPECT PILOT BEARING

Turn the bearing by hand while applying force in the axial direction.

If the bearing sticks or has much resistance, replace the pilot bearing.

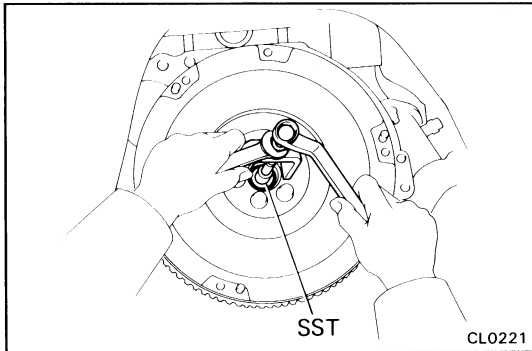

5. IF NECESSARY, REPLACE PILOT BEARING

(a) Using SST, remove the pilot bearing.

SST 09303-35011

(b) Using SST, drive in a new pilot bearing.

SST 09304-30012

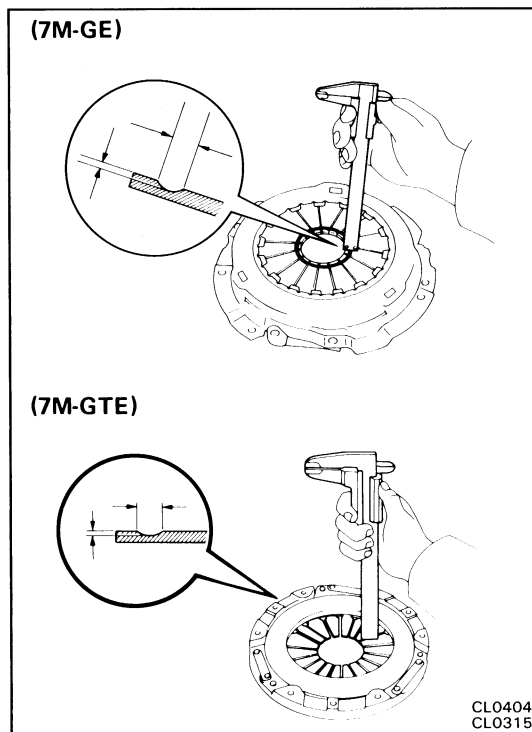
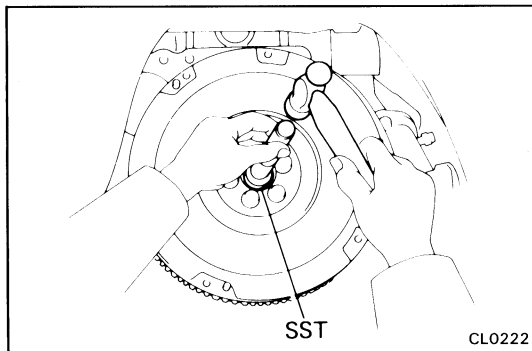

6. INSPECT DIAPHRAGM SPRING FOR WEAR

Using calipers, measure the diaphragm spring for depth and width of wear.

Limit: Depth 0.6 mm (0.024 in.)

Width 5.0 mm (0.197 in.)

If necessary, replace the clutch cover.

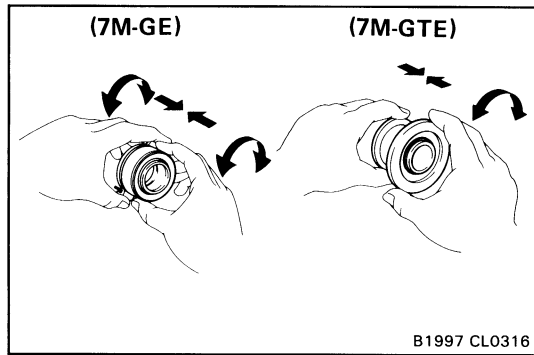

7. INSPECT RELEASE BEARING

Turn the bearing by hand while applying force in the axial direction.

If the bearing sticks or has much resistance, replace the release bearing.

HINT: The bearing is permanently lubricated and requires no cleaning or lubrication.

8. IF NECESSARY, REPLACE RELEASE BEARING (7M-GE)

Replace release bearing assembly.

(7M-GTE)

- Using snap ring pliers, remove the snap ring.
- Remove the release bearing, plate washer and cone spring from the hub.
- Install the cone spring, plate washer and a new release bearing to the hub.

HINT: Make sure to install the cone spring in correct direction as shown in the figure.

- Using snap ring pliers, install the snap ring.

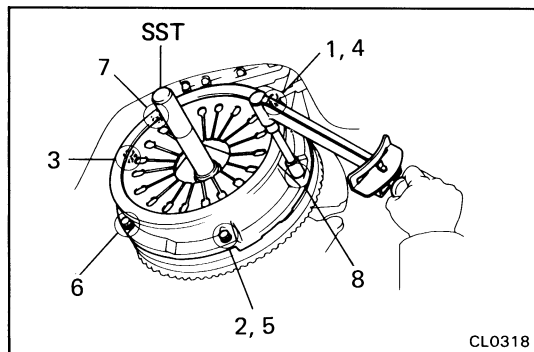
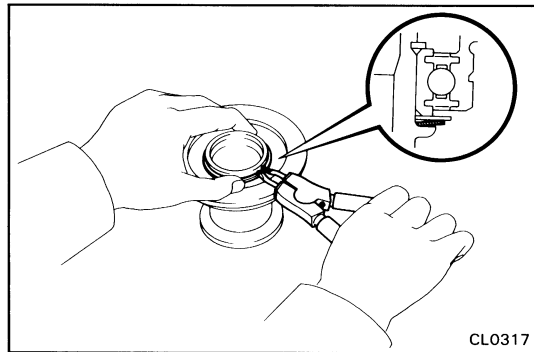

9. (7M-GTE)

CHECK DIAPHRAGM SPRING TIP ALIGNMENT

- Using SST, install the clutch disc on the flywheel. SST 09301-20020
- Align the matchmarks on the clutch cover and flywheel.
- Torque the bolts on the clutch cover in the order shown.

Torque: 195 kg-cm (14 ft-lb, 19 N·m)

HINT: Temporarily tighten the No.1 and No.2 bolts.

- Using a dial indicator and measuring point, check the diaphragm spring tip alignment.

Maximum non-alignment: 0.5 mm (0.020 in.)

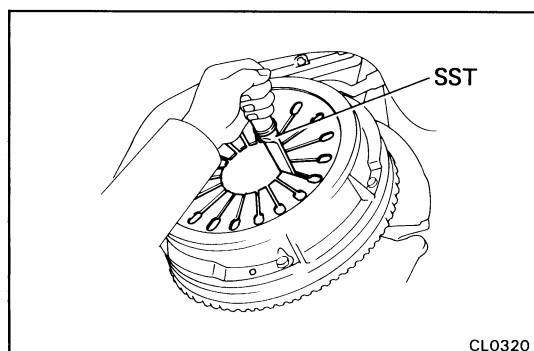
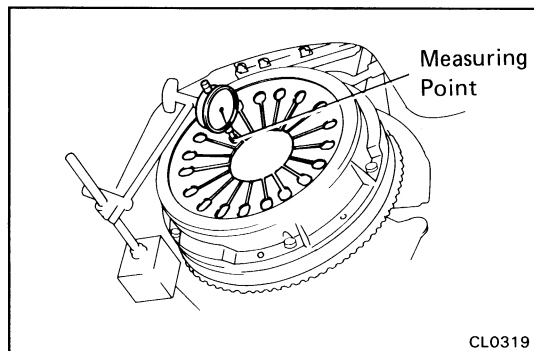

- If non-alignment is excessive, bend the springs with SST until alignment is correct.

SST 09333-00013

- Remove the clutch cover and disc.

HINT: Loosen each set bolt one turn at a time until spring tension is released.

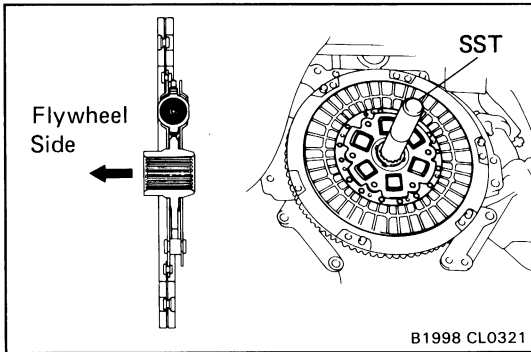

INSTALLATION OF CLUTCH UNIT

(See page CL-11)

(7M-GE)

1. INSTALL CLUTCH DISC ON FLYWHEEL

Using SST, install the disc on the flywheel.
SST 09301-20020

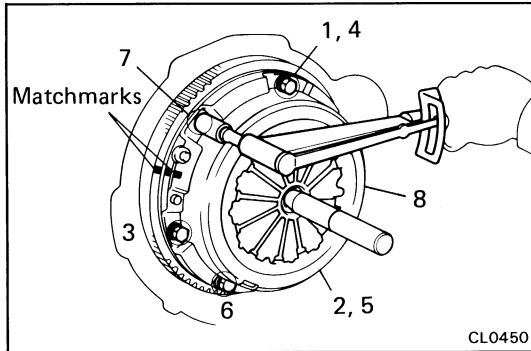

2. INSTALL CLUTCH COVER

- Align the matchmarks on the clutch cover and flywheel.
- Torque the bolts on the clutch cover in the order shown.

Torque: 195 kg-cm (14 ft-lb, 19 N·m)

HINT: Temporarily tighten the No.1 and No.2 bolts.

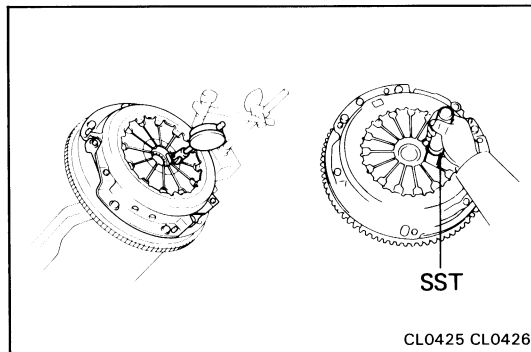

3. CHECK DIAPHRAGM SPRING TIP ALIGNMENT

Using a dial indicator with roller instrument, check the diaphragm spring tip alignment.

Maximum non-alignment: 0.5 mm (0.020 in.)

If alignment is not as specified, using SST, adjust the diaphragm spring tip alignment.

SST 09333-00013

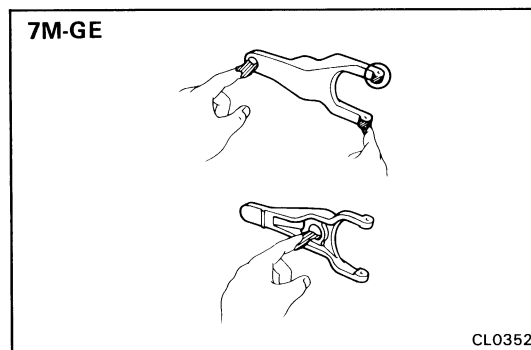

5. APPLY MOLYBDENUM DISULPHIDE LITHIUM BASE GREASE (NLGI NO. 2) OR MP GREASE

- Apply molybdenum disulphide lithium base grease to the following parts.
 - Release fork and hub contact point
 - Release fork and push rod contact point
 - Release fork pivot point
 - Clutch disc spline
 - Release bearing hub inside groove

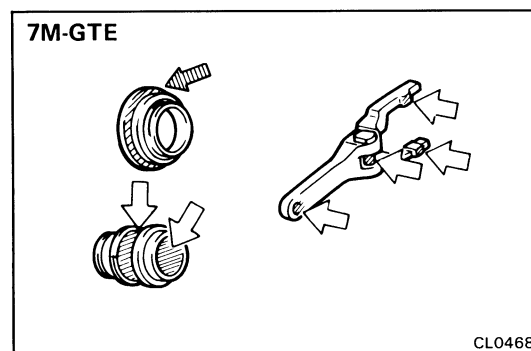

- Apply MP grease to the front surface of the release bearing.

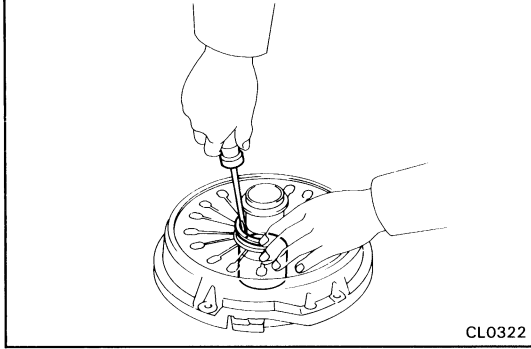
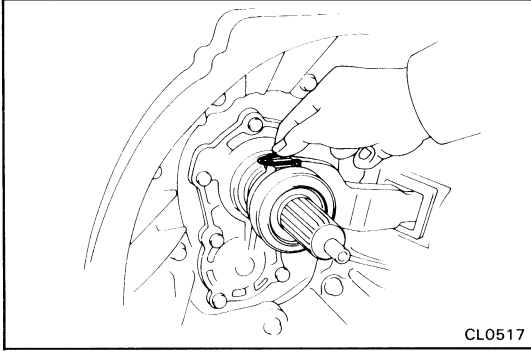

6. INSTALL BOOT, FORK AND RELEASE BEARING TO TRANSMISSION

7. INSTALL TRANSMISSION
(See page MT-6)

(7M-GTE)

1. INSTALL RELEASE BEARING HUB ASSEMBLY TO CLUTCH COVER

- (a) Apply MP grease to the release bearing contact surface.
- (b) Install the plate washer, wave washer and bearing hub assembly.
- (c) Using a screwdriver, install the snap ring.

HINT: Support the release bearing under with a spacer or such to raise the bearing hub assembly.

2. INSTALL TRANSMISSION WITH CLUTCH COVER AND DISC

(See page MT-6)