

# AUTOMATIC TRANSMISSION (A340E)

	Page
DESCRIPTION .....	AT-2
TROUBLESHOOTING .....	AT-9
Basic Troubleshooting .....	AT-9
General Troubleshooting .....	AT-10
Operating Mechanism for Each Gear .....	AT-12
Diagnosis System .....	AT-13
Preliminary Check .....	AT-18
Manual Shifting Test .....	AT-20
Electronic Control System .....	AT-21
Mechanical System Tests .....	AT-32
Automatic Shift Schedule .....	AT-40
Neutral Start Switch .....	AT-41
ON-VEHICLE REPAIR .....	AT-42
Valve Body	
Parking Lock Pawl	
Extension Housing	
Speedometer Driven Gear	
REMOVAL AND INSTALLATION OF TRANSMISSION .....	AT-43
TORQUE CONVERTER AND DRIVE PLATE .....	AT-45
REMOVAL OF COMPONENT PARTS .....	AT-46
COMPONENT PARTS .....	AT-65
General Notes .....	AT-65
Oil Pump .....	AT-66
Overdrive Planetary Gear, Overdrive Direct Clutch and Overdrive One-Way Clutch .....	AT-70
Overdrive Brake .....	AT-78
Direct Clutch .....	AT-82
Forward Clutch .....	AT-87
Second Coast Brake .....	AT-93
Front Planetary Gear .....	AT-95
Planetary Sun Gear and No. 1 One-Way Clutch .....	AT-96
Second Brake .....	AT-100
First and Reverse Brake .....	AT-103
Rear Planetary Gear, No. 2 One-Way Clutch and Output Shaft .....	AT-104
Valve Body .....	AT-109
• Disassembly of Valve Body .....	AT-109
• Upper Valve Body .....	AT-111
• Lower Valve Body .....	AT-114
• Assembly of Valve Body .....	AT-117
Transmission Case .....	AT-118
Extension Housing .....	AT-118
INSTALLATION OF COMPONENT PARTS .....	AT-119
SHIFT LOCK SYSTEM .....	AT-142

# DESCRIPTION

## GENERAL

The A340E is a 4-speed, Electronic Controlled Transmission (hereafter called ECT) developed for use with high-performance engines such as the 7M-GE and 7M-GTE. A lock-up mechanism is built into the torque converter.

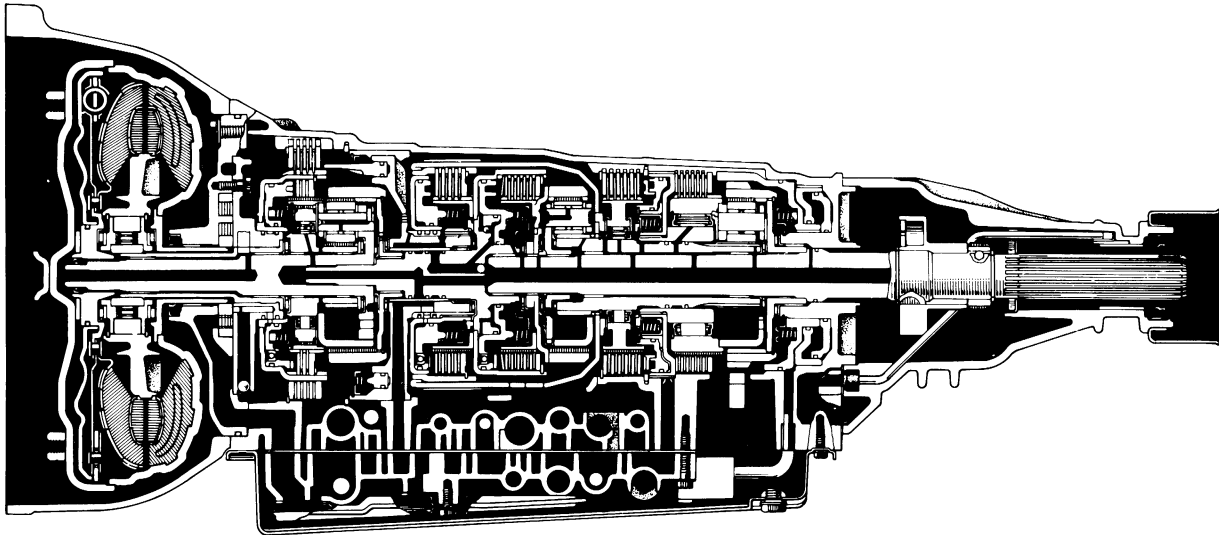

D1328

The A340E transmission is mainly composed of the torque converter, the overdrive (hereafter called O/D) planetary gear unit, 3-speed planetary gear unit, the hydraulic control system and the electronic control system.

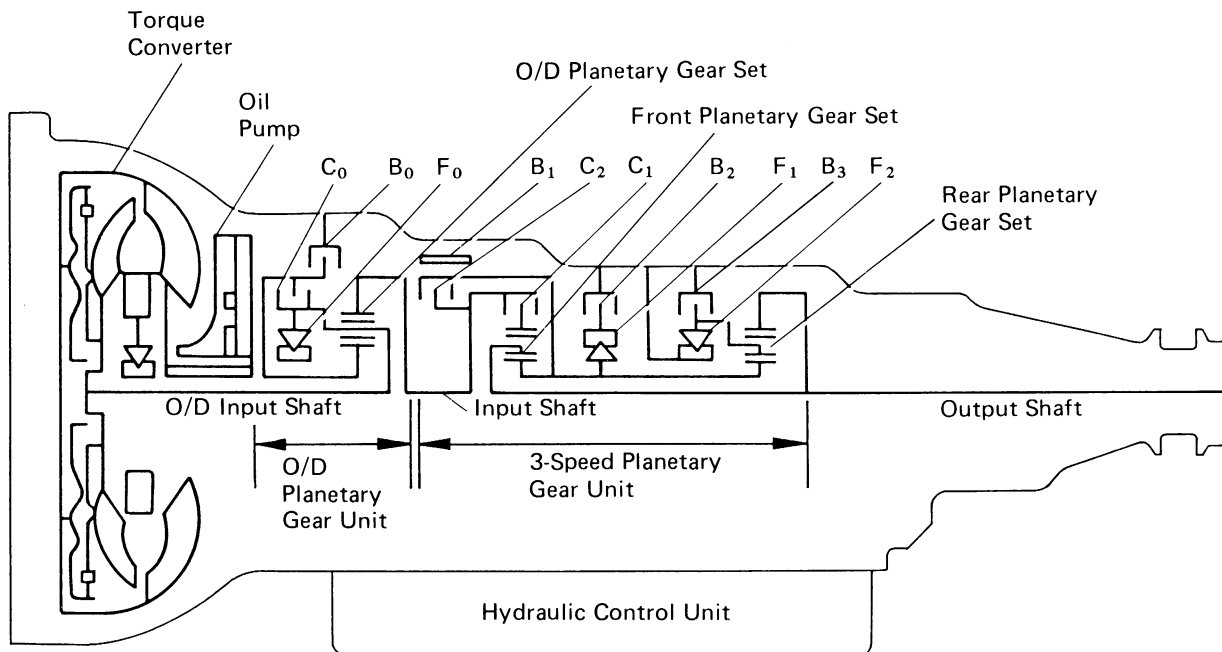

AT3253

## Outline of ECT

The conventional automatic transmission operates by mechanically converting vehicle speed into governor pressure, and throttle opening into throttle pressure, and using these hydraulic pressures to control the operation of the clutches and brakes in the planetary gear unit, thus controlling the timing of up-shift and down-shift of the transmission. This is called the "hydraulic control method."

In the case of the ECT, on the other hand, sensors electronically sense the speed of the vehicle and the throttle opening and send these information to the electronic controlled unit (hereafter called ECU) in the form of electrical signals. The ECU then controls the operation of the clutches and brakes based on these data, thus controlling the timing of the shift points.

## SHIFT CONTROL

- **Hydraulic Controlled Transmission**

Shifting in the fully hydraulic controlled automatic transmission is carried out by the hydraulic control unit in the following way:

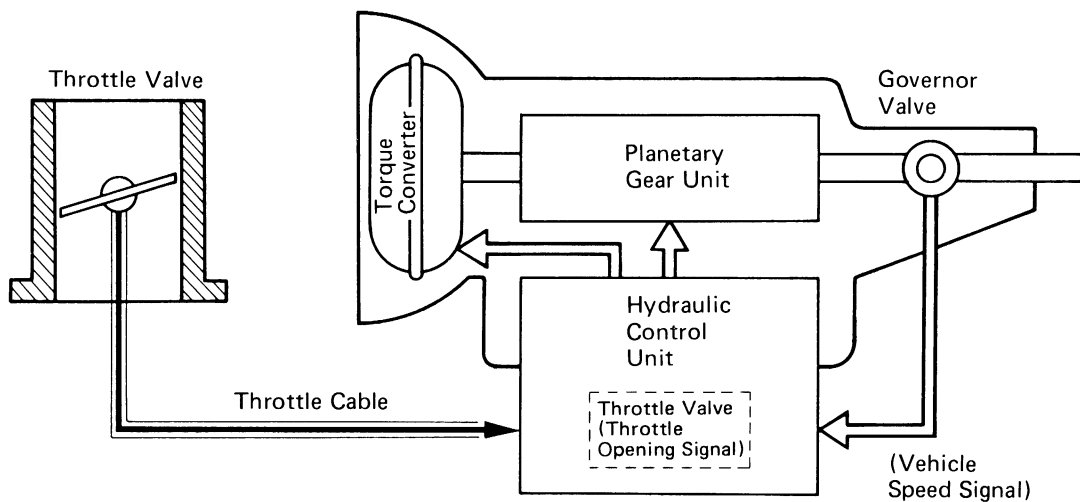

AT3254

### THROTTLE VALVE

The throttle valve in the hydraulic control unit generates hydraulic pressure in proportion to the amount that the accelerator pedal is depressed; this pressure (called "throttle pressure") acts as a throttle opening "signal" to the hydraulic control unit.

### GOVERNOR VALVE

The governor valve generates hydraulic pressure in proportion to the speed of the vehicle; this pressure (called "governor pressure") acts as a vehicle speed "signal" to the hydraulic control unit.

### HYDRAULIC CONTROL UNIT

Governor pressure and throttle pressure cause the shift valves in the hydraulic control unit to operate; the strengths of these pressures control the movements of these valves, and these valves control the fluid passage to the clutches and brakes in the planetary gear unit, which in turn control the shifting of the transmission.

• ECT

Aside from having an ECU which controls shifting based upon electrical speed and throttle opening signals, the ECT is basically the same as a fully hydraulic controlled automatic transmission. The ECT controls shifting in the following manner:

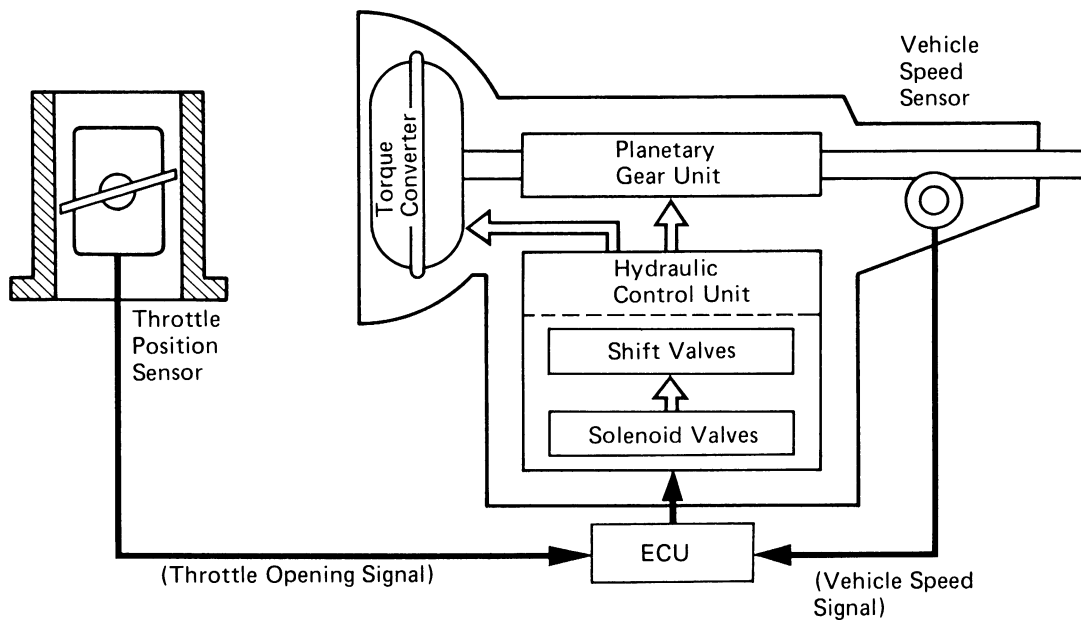

AT3255

**THROTTLE POSITION SENSOR**

The throttle opening is sensed by the throttle position sensor, which sends this data to the ECU in the form of electrical signals.

**VEHICLE SPEED SENSOR**

The vehicle speed is sensed by the vehicle speed sensor, which sends this data to the ECU in the form of electrical signals.

**ECU**

The ECU determines the shift timing on the basis of the vehicle speed and throttle opening signals, and operates the solenoid valves in the hydraulic control unit, thus controlling the movement of the shift valves. These valves in turn control the fluid passage to the clutches and brakes in the planetary gear unit, which control the shifting of the transmission.

### PLANETARY GEAR UNIT

The planetary gear unit is composed of three sets of planetary gears, three clutches which transmit power to the planetary gears, and four brakes and three one-way clutches which immobilize the planetary carrier and planetary sun gear.

Power from the engine transmitted the input shaft via the torque converter is then transmitted to the planetary gears by the operation of the clutches. By operation of the brakes and one-way clutches, either the planetary carrier or the planetary sun gear is immobilized, altering the speed of revolution of the planetary gear unit. Shift change is carried out by altering the combination of clutch and brake operation.

Each clutch and brake operates by hydraulic pressure; gear position is decided according to the throttle opening angle and vehicle speed, and shift change automatically occurs.

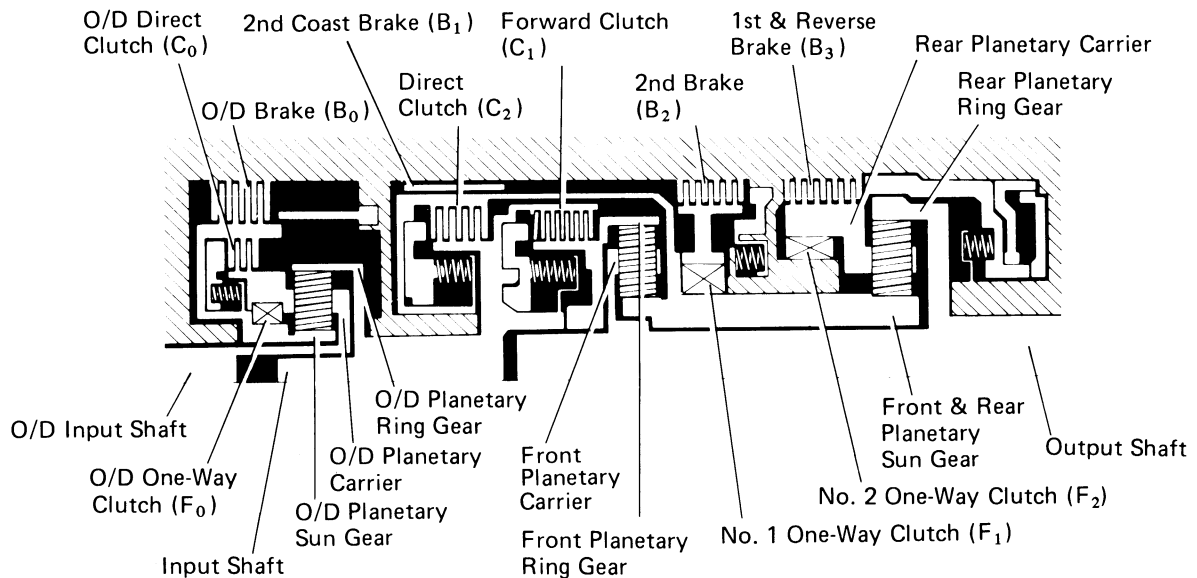

AT2157

### OPERATION OF EACH ELEMENT

NOMENCLATURE	OPERATION
O/D Direct Clutch (C <sub>0</sub> )	Connects overdrive sun gear and overdrive carrier
O/D Brake (B <sub>0</sub> )	Prevents overdrive sun gear from turning either clockwise or counterclockwise
O/D One-Way Clutch (F <sub>0</sub> )	When transmission is being driven by engine, connects overdrive sun gear and overdrive carrier
Forward Clutch (C <sub>1</sub> )	Connects input shaft and front planetary ring gear
Direct Clutch (C <sub>2</sub> )	Connects input shaft and front & rear planetary sun gear
2nd Coast Brake (B <sub>1</sub> )	Prevents front & rear planetary sun gear from turning either clockwise or counterclockwise
2nd Brake (B <sub>2</sub> )	Prevents outer race of F <sub>1</sub> from turning either clockwise or counterclockwise, thus preventing front & rear planetary sun gear from turning counterclockwise
1st & Reverse Brake (B <sub>3</sub> )	Prevents rear planetary carrier from turning either clockwise or counterclockwise
No. 1 One-Way Clutch (F <sub>1</sub> )	When B <sub>2</sub> is operating, prevents front & rear planetary sun gear from turning counterclockwise
No. 2 One-Way Clutch (F <sub>2</sub> )	Prevents rear planetary carrier from turning counterclockwise

### OPERATING CONDITIONS FOR EACH GEAR

(See page AT-12)

## HYDRAULIC CONTROL SYSTEM

The hydraulic control system is composed of the oil pump, the valve body, the solenoid valves, and the clutches and brakes, as well as the fluid passages which connect all of these components. Based on the hydraulic pressure created by the oil pump, the hydraulic control system governs the hydraulic pressure acting on the torque converter, clutches and brakes in accordance with the vehicle driving conditions.

There are three solenoid valves on the valve body. These solenoid valves are turned on and off by signals from the ECU to operate the shift valves. These shift valves then switch the fluid passages so that fluid goes to the torque converter and planetary gear units.

(Except for the solenoid valves, the hydraulic control system of the ECT is basically the same as that of the fully hydraulic controlled automatic transmission.)

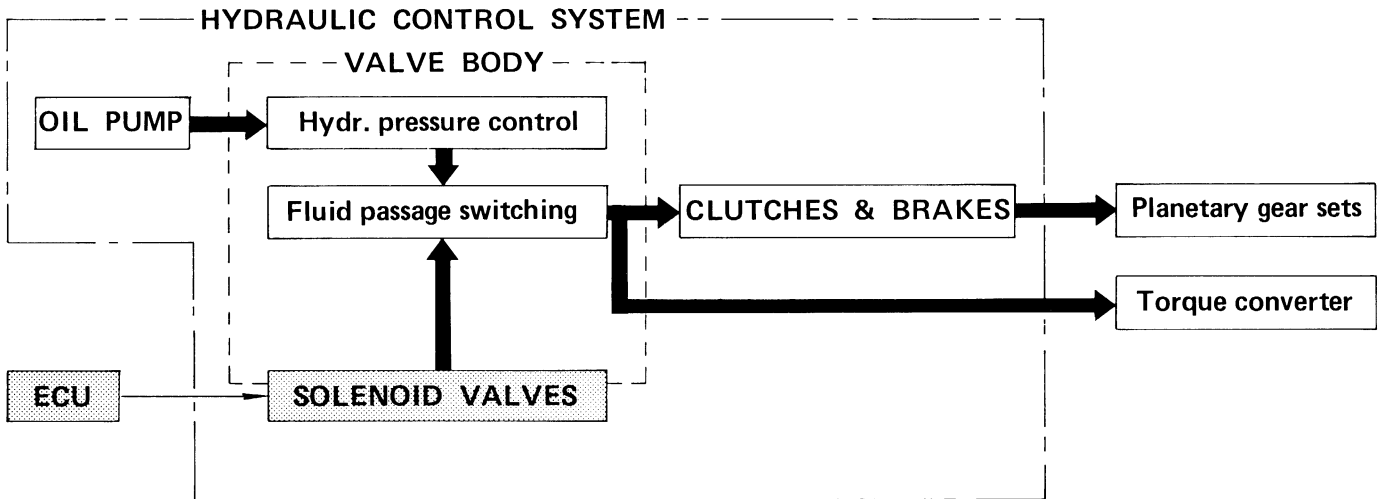

- **LINE PRESSURE**

Line pressure is the most basic and important pressure used in the automatic transmission, because it is used to operate all of the clutches and brakes in the transmission.

If the primary regulator valve does not operate correctly, line pressure will be either too high or too low. Line pressure that is too high will lead to shifting shock and consequent engine power loss due to the greater effort required of the oil pump; line pressure that is too low will cause slippage of clutches and brakes, which will, in extreme cases, prevent the vehicle from moving. Therefore, if either of these problems are noted, the line pressure should be measured to see if it is within standard.

- **THROTTLE PRESSURE**

Throttle pressure is always kept in accordance with the opening angle of the engine throttle valve. This throttle pressure acts on the primary regulator valve and, accordingly, line pressure is regulated in response to the throttle valve opening.

In the fully hydraulic controlled automatic transmission, throttle pressure is used for regulating line pressure and as signal pressure for up-shift and down-shift of the transmission. In the ECT, however, throttle pressure is used only for regulating line pressure. Consequently, improper adjustment of the transmission throttle cable may result in a line pressure that is too high or too low. This, in turn, will lead to shifting shock or clutch and brake slippage.

## ELECTRONIC CONTROL SYSTEM

The electronic control system, which controls the shift points and the operation of the lock-up clutch, is composed of the following three parts:

### 1. Sensors

These sensors sense the vehicle speed, throttle opening and other conditions and send this data to the ECU in the form of electrical signals.

### 2. ECU

The ECU determines the shift and lock-up timing based upon the signals from sensors, and controls the solenoid valves of the hydraulic control unit accordingly.

### 3. Actuators

These are three solenoid valves that control hydraulic pressure acting on the hydraulic valves to control shifting and lock-up timing.

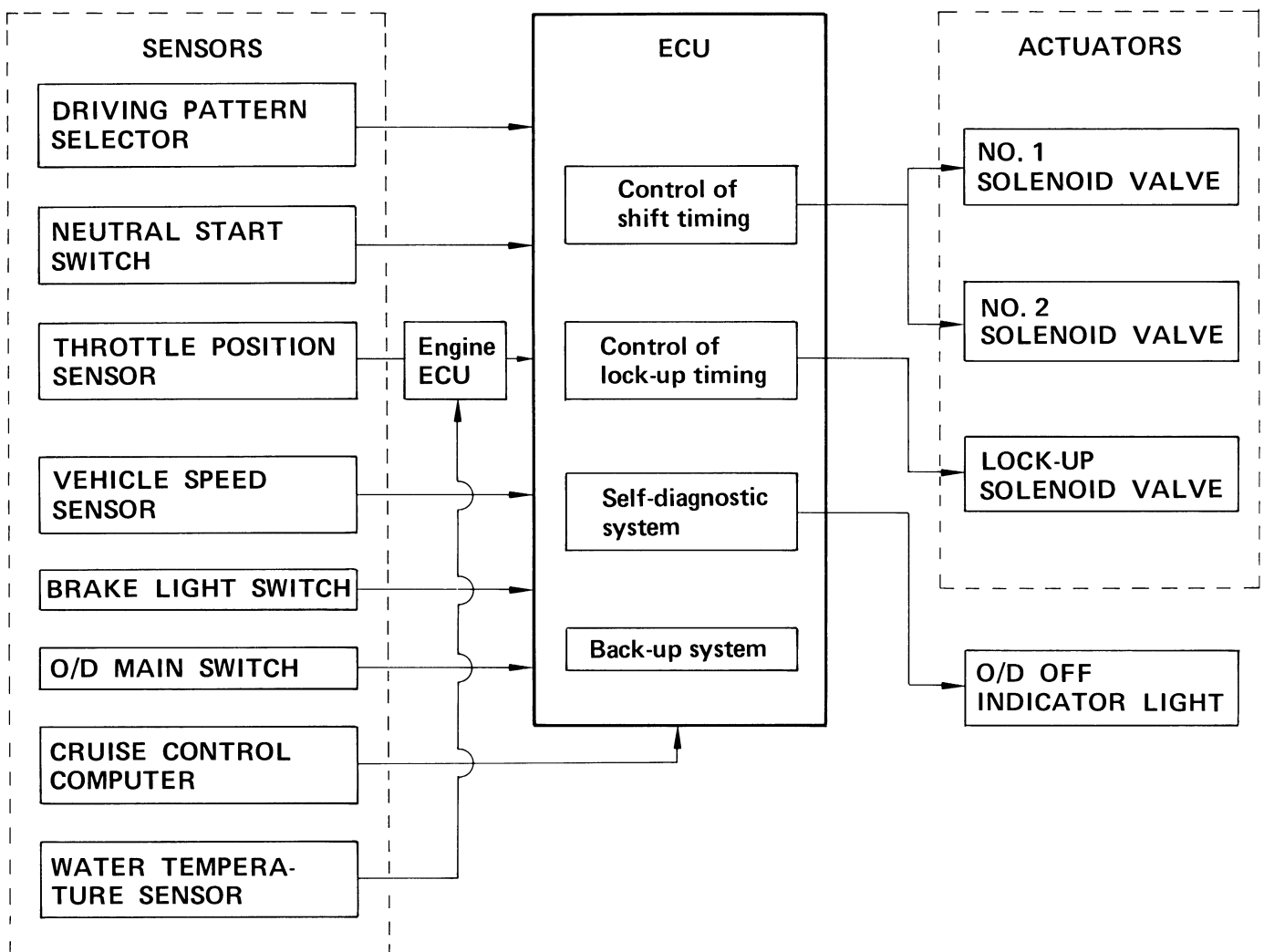

**FUNCTION OF ECU****• Control of Shift Timing**

The ECU has programmed into its memory the optimum shift pattern for each shift lever position (D, 2, L range) and driving mode (Normal or Power).

Based on the appropriate shift pattern, the ECU turns No. 1 and No. 2 solenoid valves on or off in accordance with the vehicle speed signal from the vehicle speed sensor and the throttle opening signal from the throttle position sensor. In this manner, the ECU operates each shift valve, opening or closing the fluid passages to the clutches and brakes to permit up-shift or down-shift of the transmission.

**HINT:** The electronic control system provides shift timing and lock-up control only while the vehicle is traveling forward. In REVERSE, PARK, and NEUTRAL, the transmission is mechanically, not electronically controlled.

**• Control of Overdrive**

Driving in overdrive is possible if the O/D main switch is on and the shift lever is in the D range. However, when the vehicle is being driven using the cruise control system (CCS), if the actual vehicle speed drops to about 4 km/h (2 mph) below the set speed while the vehicle is running in overdrive, the CCS computer sends a signal to the ECT ECU to release the overdrive and prevent the transmission from shifting back into overdrive until the actual vehicle speed reaches the speed set in the CCS memory.

On this model, if the coolant temperature falls below 60°C (140°F), the Engine ECU sends a signal to the ECT ECU, preventing the transmission from up-shifting into overdrive.

**• Control of Lock-Up System**

The ECT ECU has programmed in its memory a lock-up clutch operation pattern for each driving mode (Normal or Power). Based on this lock-up pattern, the ECU turns lock-up solenoid valve on or off in accordance with the vehicle speed signals received from the vehicle speed sensor and the throttle opening signals from the throttle position sensor.

Depending on whether lock-up solenoid valve is on or off, the lock-up relay valve performs changeover of the fluid passages for the converter pressure acting on the torque converter to engage or disengage the lock-up clutch.

(Mandatory Cancellation of Lock-up System)

If any of the following conditions exist, the ECU turns off lock-up solenoid valve to disengage the lock-up clutch.

- 1) The brake light switch comes on (during braking).
- 2) The IDL points of the throttle position sensor close (throttle valve fully closed).
- 3) The vehicle speed drops 4 km/h (2 mph) or more below the set speed while the cruise control system is operating.
- 4) The coolant temperature falls below 60°C (140°F) and vehicle speed is under 60 km/h (37 mph), or 35°C (95°F) and vehicle speed is under 40 km/h (25 mph).

The purpose of 1) and 2) above is to prevent the engine from stalling if the rear wheels lock up. The purpose of 3) is to cause the torque converter to operate to obtain torque multiplication. The purpose of 4) is both to improve general driveability, and to speed up transmission warm-up.

Also, while the lock-up system is in operation, the ECU will temporarily turn it off during up-shift or down-shift in order to decrease shifting shock.



# TROUBLESHOOTING

## Basic Troubleshooting

Before troubleshooting an ECT, first determine whether the problem is electrical or mechanical. To do this, just refer to the basic troubleshooting flow-chart provided below.

If the cause is already known, using the basic troubleshooting chart below along with the general troubleshooting chart on the following pages should speed the procedure.

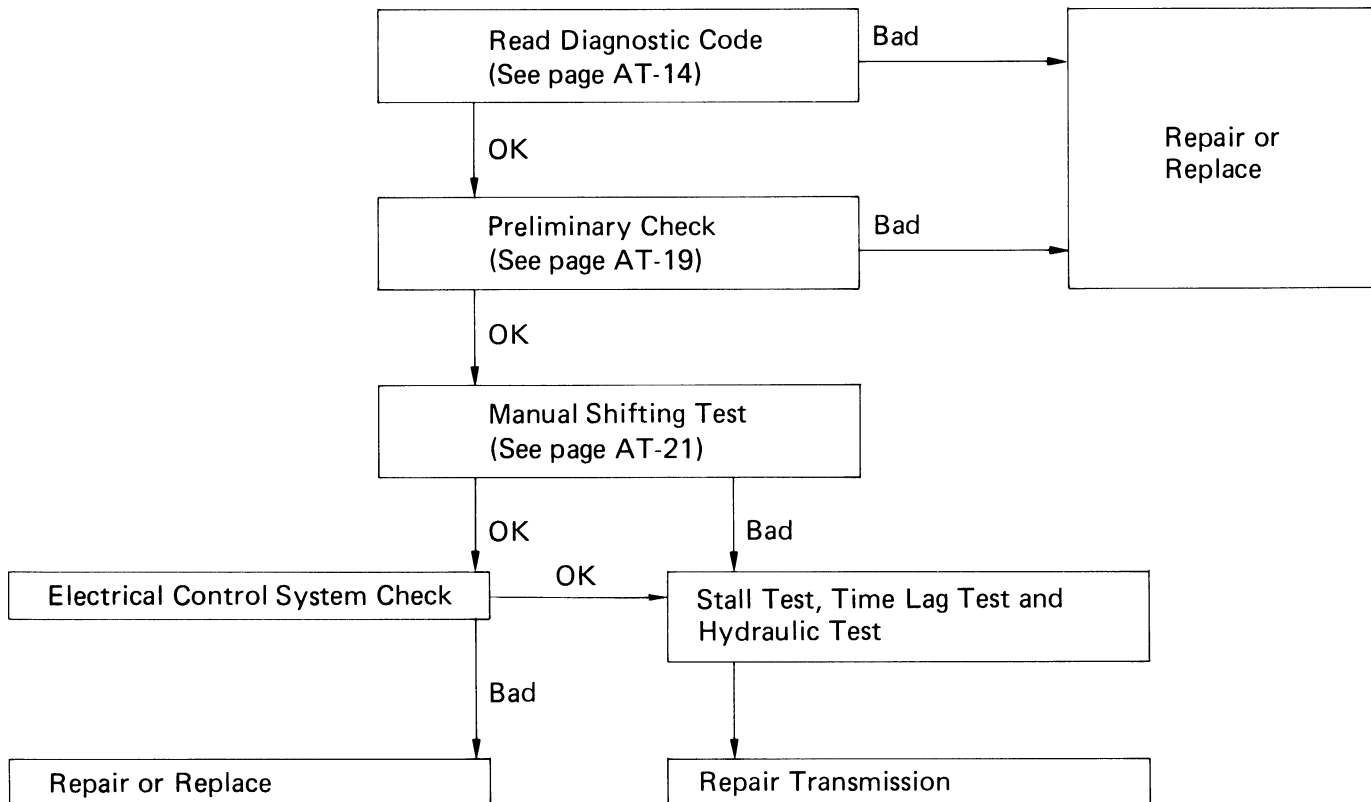

## General Troubleshooting

Problem	Possible cause	Remedy	Page
Fluid discolored or smells burnt	Fluid contaminated Torque converter faulty Transmission faulty	Replace fluid Replace torque converter Disassemble and inspect transmission	AT-18 AT-43 AT-46
Vehicle does not move in any forward range or reverse	Manual linkage out of adjustment Valve body or primary regulator faulty Parking lock pawl faulty Torque converter faulty Converter drive plate broken Oil pump intake screen blocked Transmission faulty	Adjust linkage Inspect valve body Inspect parking lock pawl Replace torque converter Replace drive plate Clean screen Disassemble and inspect transmission	AT-19 AT-109 AT-42 AT-43 AT-43 AT-51 AT-46
Shift lever position incorrect	Manual linkage out of adjustment Manual valve and lever faulty Transmission faulty	Adjust linkage Inspect valve body Disassemble and inspect transmission	AT-19 AT-109 AT-46
Harsh engagement into any drive range	Throttle cable out of adjustment Valve body or primary regulator faulty Accumulator pistons faulty Transmission faulty	Adjust throttle cable Inspect valve body Inspect accumulator pistons Disassemble and inspect transmission	AT-19 AT-109 AT-135, 136 AT-46
Delayed 1-2, 2-3 or 3-O/D up-shift, or down-shifts from O/D-3 or 3-2 and shifts back to O/D or 3	Electronic control faulty Valve body faulty Solenoid valve faulty	Inspect electronic control Inspect valve body Inspect solenoid valve	AT-21 AT-109 AT-30
Slips on 1-2, 2-3 or 3-O/D up-shift, or slips or shudders on acceleration	Manual linkage out of adjustment Throttle cable out of adjustment Valve body faulty Solenoid valve faulty Transmission faulty	Adjust linkage Adjust throttle cable Inspect valve body Inspect solenoid valve Disassemble and inspect transmission	AT-19 AT-19 AT-109 AT-30 AT-46
Drag, binding or tie-up on 1-2, 2-3 or 3-O/D up-shift	Manual linkage out of adjustment Valve body faulty Transmission faulty	Adjust linkage Inspect valve body Disassemble and inspect transmission	AT-19 AT-109 AT-46

## General Troubleshooting (Cont'd)

Problem	Possible cause	Remedy	Page
No lock-up in 2nd, 3rd or O/D	Electronic control faulty Valve body faulty Solenoid valve faulty Transmission faulty	Inspect electronic control Inspect valve body Inspect solenoid valve Disassemble and inspect transmission	AT-21 AT-109 AT-30 AT-46
Harsh down-shift	Throttle cable out of adjustment Throttle cable and cam faulty Accumulator pistons faulty  Valve body faulty Transmission faulty	Adjust throttle cable Inspect throttle cable and cam Inspect accumulator pistons  Inspect valve body Disassemble and inspect transmission	AT-19 AT-136 AT-135, 136  AT-109 AT-46
No down-shift when coasting	Valve body faulty Solenoid valve faulty Electronic control faulty	Inspect valve body Inspect solenoid valve Inspect electronic control	AT-109 AT-30 AT-21
Down-shift occurs too quickly or too late while coasting	Throttle cable faulty Valve body faulty Transmission faulty  Solenoid valve faulty Electronic control faulty	Inspect throttle cable Inspect valve body Disassemble and inspect transmission  Inspect solenoid valve Inspect electronic control	AT-19 AT-109 AT-46  AT-30 AT-21
No O/D-3, 3-2 or 2-1 kick-down	Solenoid valve faulty Electronic control faulty Valve body faulty	Inspect solenoid valve Inspect electronic control Inspect valve body	AT-30 AT-21 AT-109
No engine braking in 2 or L range	Solenoid valve faulty Electronic control faulty Valve body faulty Transmission faulty	Inspect solenoid valve Inspect electronic control Inspect valve body Disassemble and inspect transmission	AT-30 AT-21 AT-109 AT-46
Vehicle does not hold in P	Manual linkage out of adjustment Parking lock pawl cam and spring faulty	Adjust linkage Inspect cam and spring	AT-19 AT-42

# Operating Mechanism for Each Gear

## 1. CLUTCH, BRAKE AND ONE-WAY CLUTCH

○ ..... Operating

Shift lever position	Gear position	C <sub>0</sub>	C <sub>1</sub>	C <sub>2</sub>	B <sub>0</sub>	B <sub>1</sub>	B <sub>2</sub>	B <sub>3</sub>		F <sub>0</sub>	F <sub>1</sub>	F <sub>2</sub>
								I.P.	O.P.			
P	Parking	○										
R	Reverse	○		○				○	○	○		
N	Neutral	○										
D	1st	○	○							○		○
	2nd	○	○				○			○	○	
	3rd	○	○	○			○			○		
	O/D		○	○	○		○					
2	1st	○	○							○		○
	2nd	○	○			○	○			○	○	
	3rd	○	○	○			○			○		
L	1st	○	○					○	○	○		○
	*2nd	○	○			○	○			○	○	

\* Down-shift only in the L range and 2nd gear – no up-shift.

I.P. .... Inner Piston

O.P. .... Outer Piston

## 2. SOLENOID

Possible gear positions in accordance with solenoid operating conditions.

Range	NORMAL			NO. 1 SOLENOID MALFUNCTIONING			NO. 2 SOLENOID MALFUNCTIONING			BOTH SOLENOIDS MALFUNCTIONING		
	Solenoid Valve		Gear Position	Solenoid Valve		Gear Position	Solenoid Valve		Gear Position	Solenoid Valve		Gear Position
	No. 1	No. 2		No. 1	No. 2		No. 1	No. 2		No. 1	No. 2	
D range	ON	OFF	1st	X	ON (OFF)	3rd (O/D)	ON	X	1st	X	X	O/D
	ON	ON	2nd	X	ON	3rd	OFF (ON)	X	O/D (1st)	X	X	O/D
	OFF	ON	3rd	X	ON	3rd	OFF	X	O/D	X	X	O/D
	OFF	OFF	O/D	X	OFF	O/D	OFF	X	O/D	X	X	O/D
2 range	ON	OFF	1st	X	ON (OFF)	3rd (O/D)	ON	X	1st	X	X	3rd
	ON	ON	2nd	X	ON	3rd	OFF (ON)	X	3rd (1st)	X	X	3rd
	OFF	ON	3rd	X	ON	3rd	OFF	X	3rd	X	X	3rd
L range	ON	OFF	1st	X	OFF	1st	ON	X	1st	X	X	1st
	ON	ON	2nd	X	ON	2nd	ON	X	1st	X	X	1st

( ): No fail-safe function      X : Malfunctions

# Diagnosis System

## DESCRIPTION

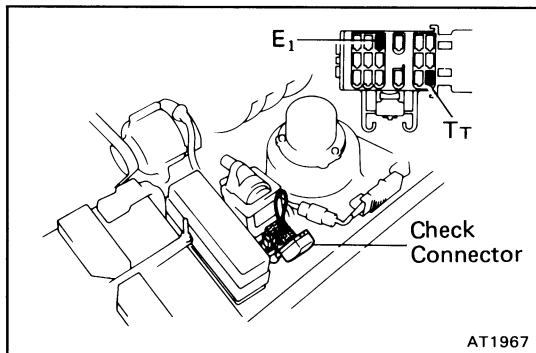
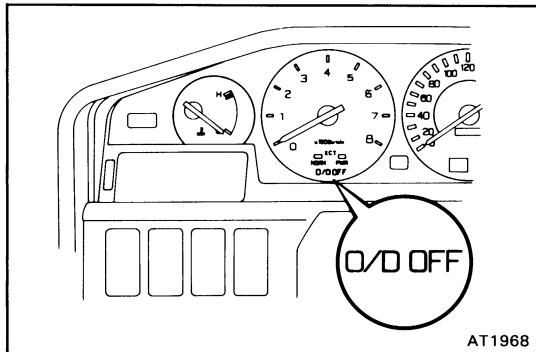

1. A self-diagnosis function is built into the electrical control system. Warning is indicated by the overdrive OFF indicator light.

HINT: Warning and diagnostic codes can be read only when the overdrive switch is ON. If OFF, the overdrive OFF light is lit continuously and will not blink.

- (a) If a malfunction occurs within the speed sensors (No. 1 or 2) or solenoids (No. 1 or 2), the overdrive OFF light will blink to warn the driver. However, there will be no warning of a malfunction with lock-up solenoid.
- (b) The diagnostic code can be read by the number of blinks of the overdrive OFF indicator light when connect check terminals T<sub>T</sub> and E<sub>1</sub>. (See page AT-14)
- (c) The throttle position sensor or brake signal are not indicated, but inspection can be made by checking the voltage at terminal T<sub>T</sub> of the check connector (diagnosis).
- (d) The signals to each gear can be checked by measuring the voltage at terminal T<sub>T</sub> of the check connector while driving.

2. The diagnostic code (trouble code) is retained in memory by the CPU (of ECT ECU) and due to back-up voltage, is not canceled out when the engine is turned off. Consequently, after repair, it is necessary to turn the ignition switch off and remove the fuse DOME (20A) or disconnect the ECT ECU connector to cancel out the diagnostic (trouble) code. (See page AT-15)

HINT:

- Low battery voltage will cause faulty operation of the diagnosis system. Therefore, always check the battery first.
- Use a voltmeter and ohmmeter that have an impedance of at least 10kΩ/V.

## CHECK "O/D OFF" INDICATOR LIGHT

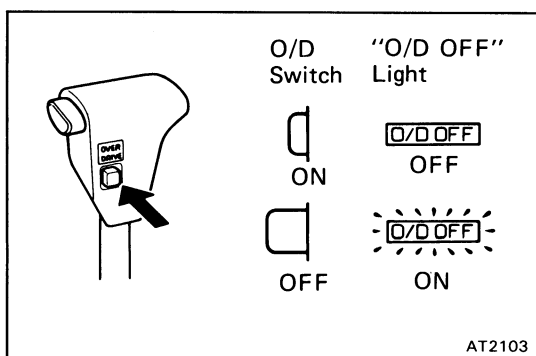

1. Turn the ignition switch ON.
2. The "O/D OFF" light will come on when the O/D switch is placed at OFF.
3. When the O/D switch is set to ON, the "O/D OFF" light should go out.

If the "O/D OFF" light flashes when the O/D switch is set to ON, the electronic control system is faulty.

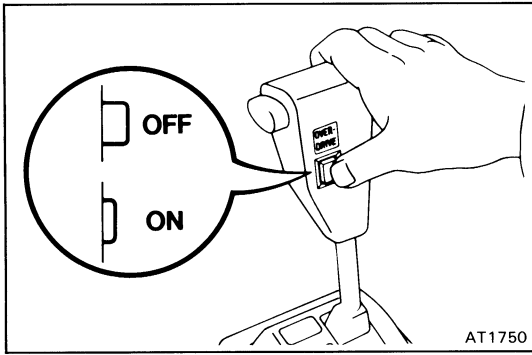

**READ DIAGNOSTIC CODE**

**1. TURN IGNITION SWITCH AND O/D SWITCH TO ON**

Do not start the engine.

HINT: Warning and diagnostic codes can be read only when the overdrive switch is ON. If OFF, the overdrive OFF light will light continuously and will not blink.

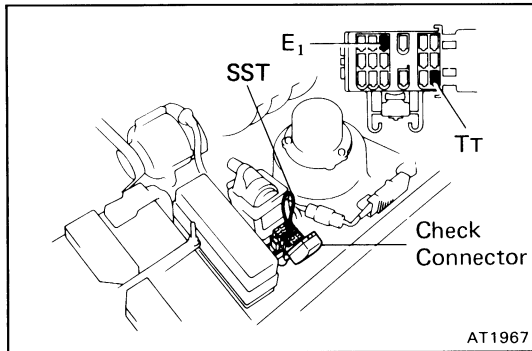

**2. CONNECT T<sub>1</sub> AND E<sub>1</sub> TERMINALS OF CHECK CONNECTOR**

Using SST, connect terminals T<sub>1</sub> and E<sub>1</sub> of the check connector.

SST 09843-18020

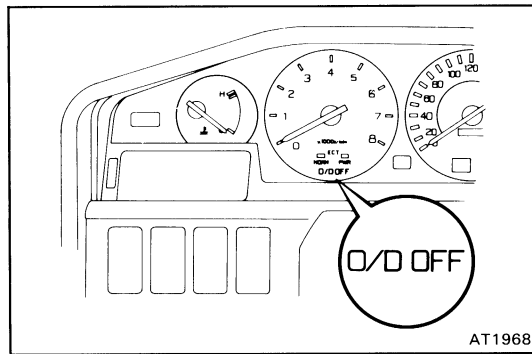

**3. READ DIAGNOSTIC CODE**

Read the diagnostic code as indicated by the number of times the O/D OFF light flashes.

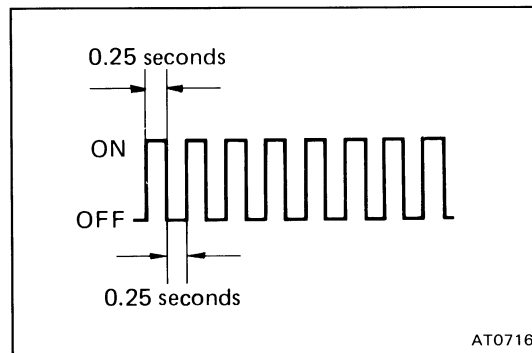

**(Diagnostic Code Indication)**

- If the system is operating normally, the light will flash 2 times per second.

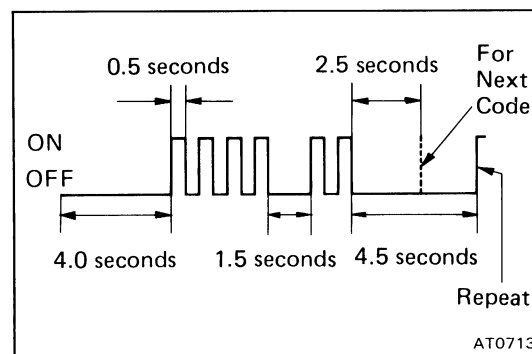







- In the event of a malfunction, the light will flash 1 time per second. The number of blinks will equal the first number and, after 1.5 seconds pause, the second number of the two digit diagnostic code. If there are two or more codes, there will be a 2.5 seconds pause between each.

HINT: In the event of several trouble codes occurring simultaneously, indication will begin from the smaller value and continue to the larger.

**4. REMOVE SST**

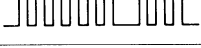
## DIAGNOSTIC CODES

Code No.	Light Pattern	Diagnosis System
—		Normal
42		Defective No. 1 speed sensor (in combination meter) — severed wire harness or short circuit
61		Defective No. 2 speed sensor (in ATM) — severed wire harness or short circuit
62		Severed No. 1 solenoid or short circuit — severed wire harness or short circuit
63		Severed No. 2 solenoid or short circuit — severed wire harness or short circuit
64		Severed lock-up solenoid or short circuit — severed wire harness or short circuit

AT2020

**HINT:** If codes 62, 63 or 64 appear, there is an electrical malfunction in the solenoid.

Causes due to mechanical failure, such as a stuck valve, will not appear.

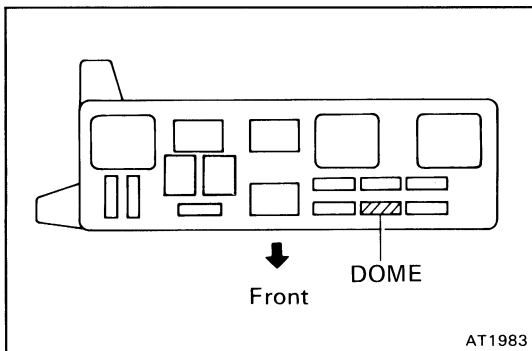

## CANCEL OUT DIAGNOSTIC CODE

- After repair of the trouble area, the diagnostic code retained in memory by the ECT ECU must be canceled by removing the fuse DOME (20A) for 10 seconds or more, depending on ambient temperature (the lower the temperature, the longer the fuse must be left out) with the ignition switch OFF.

**HINT:**

- Cancellation can be also done by removing the battery negative (—) terminal, but in this case other memory systems (TCCS diagnosis memory, etc.) will be also canceled out.
- The diagnostic code can be also canceled out by disconnecting the ECT ECU connector.
- If the diagnostic code is not canceled out, it will be retained by the ECT ECU and appear along with a new code in event of future trouble.

- After cancellation, perform a road test to confirm that a "normal code" is now read on the O/D OFF light.

**TROUBLESHOOTING FLOW-CHART**

**HINT:**

- If diagnostic code Nos. 42, 61, 62 or 63 are output, the overdrive OFF indicator light will begin to blink immediately to warn the driver. However, an impact or shock may cause the blinking to stop; but the code will still be retained in the ECT ECU memory until canceled out.
- There is no warning for diagnostic code No. 64.
- In the event of a simultaneous malfunction of both No. 1 and No. 2 speed sensors, no diagnostic code will appear and the fail-safe system will not function. However, when driving in the D range, the transmission will not up-shift from first gear, regardless of the vehicle speed.

**Diagnostic code 42 (No. 1 speed sensor circuitry)**

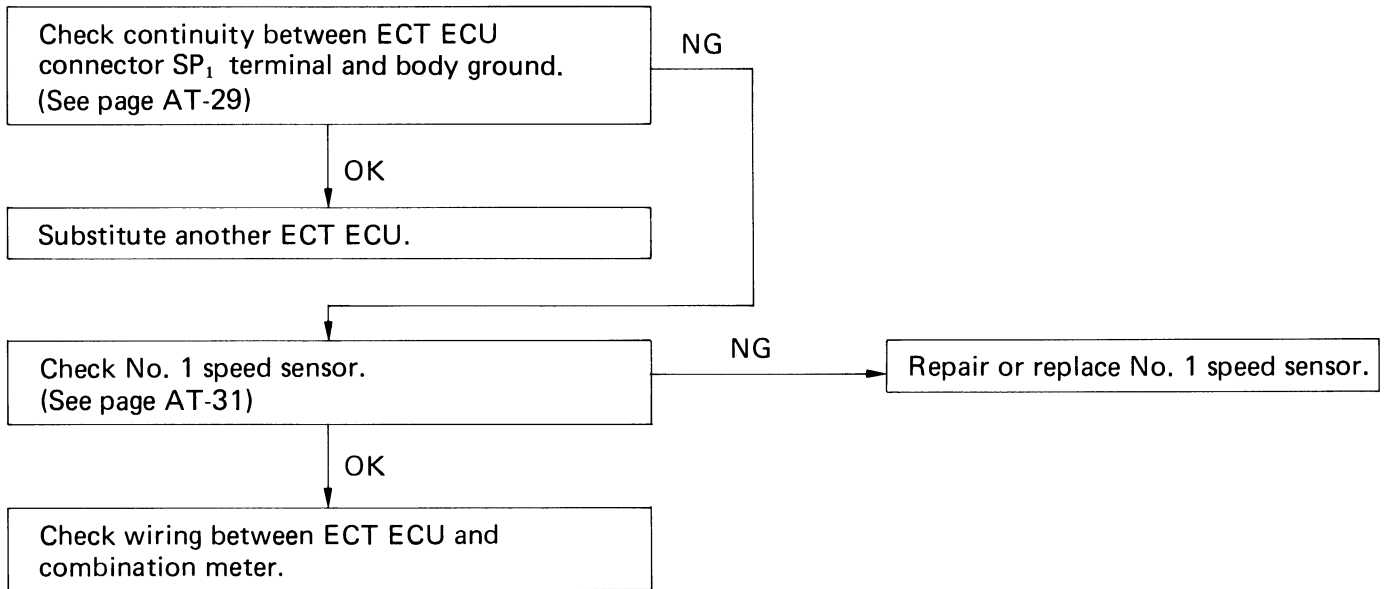

**Diagnostic code 61 (No. 2 speed sensor circuitry)**

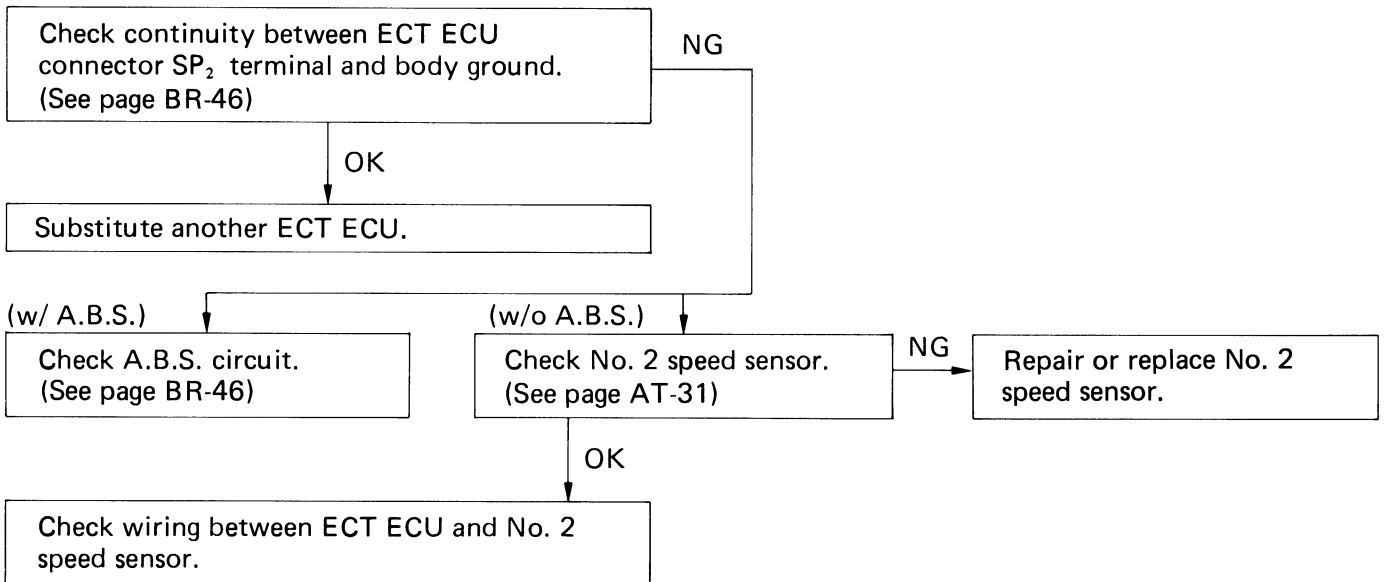



**Diagnostic code 62 (No. 1 solenoid valve circuitry)**

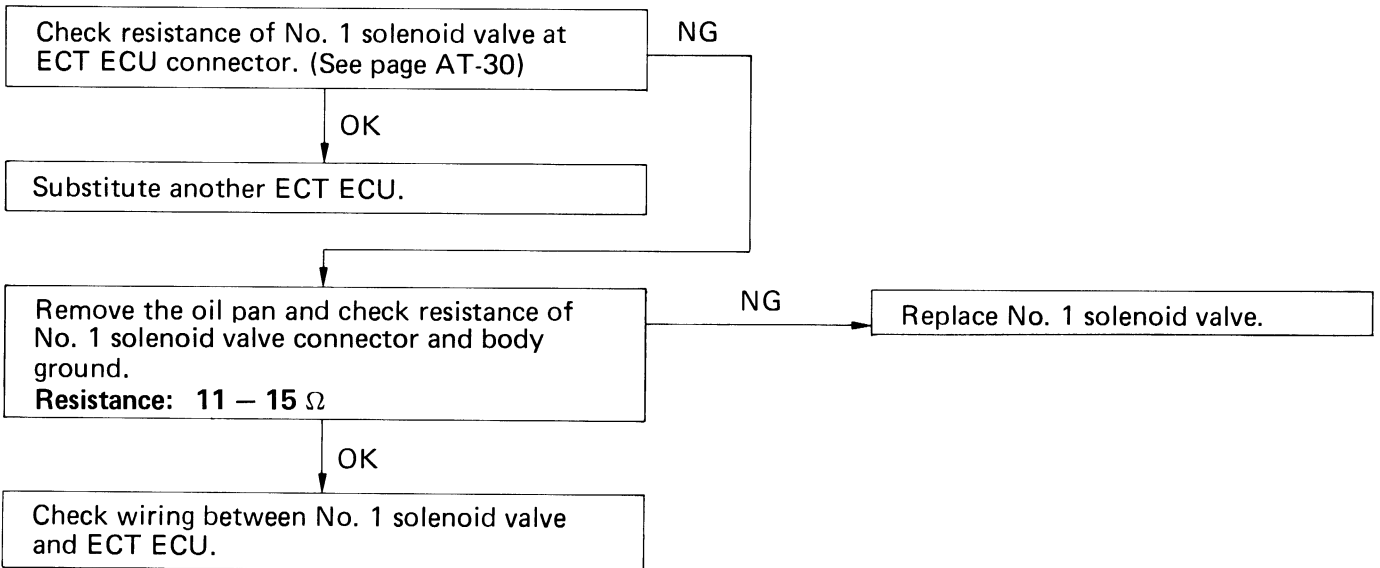

**Diagnostic code 63 (No. 2 solenoid valve circuitry)**

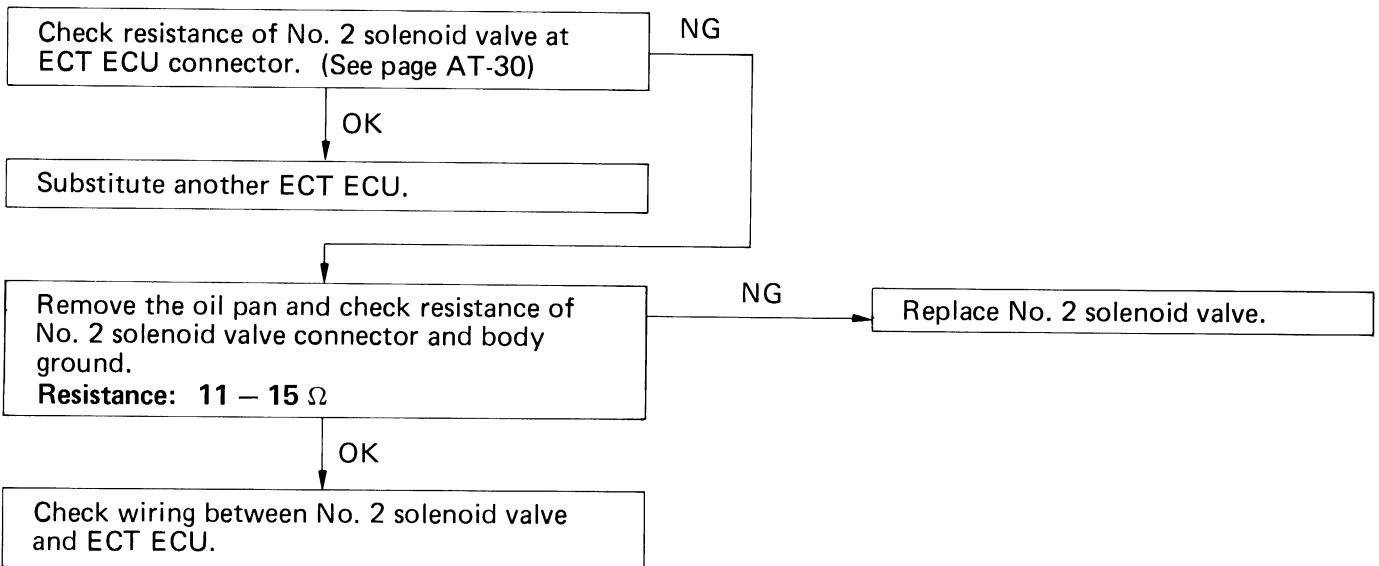

**Diagnostic code 64 (Lock-up solenoid valve circuitry)**

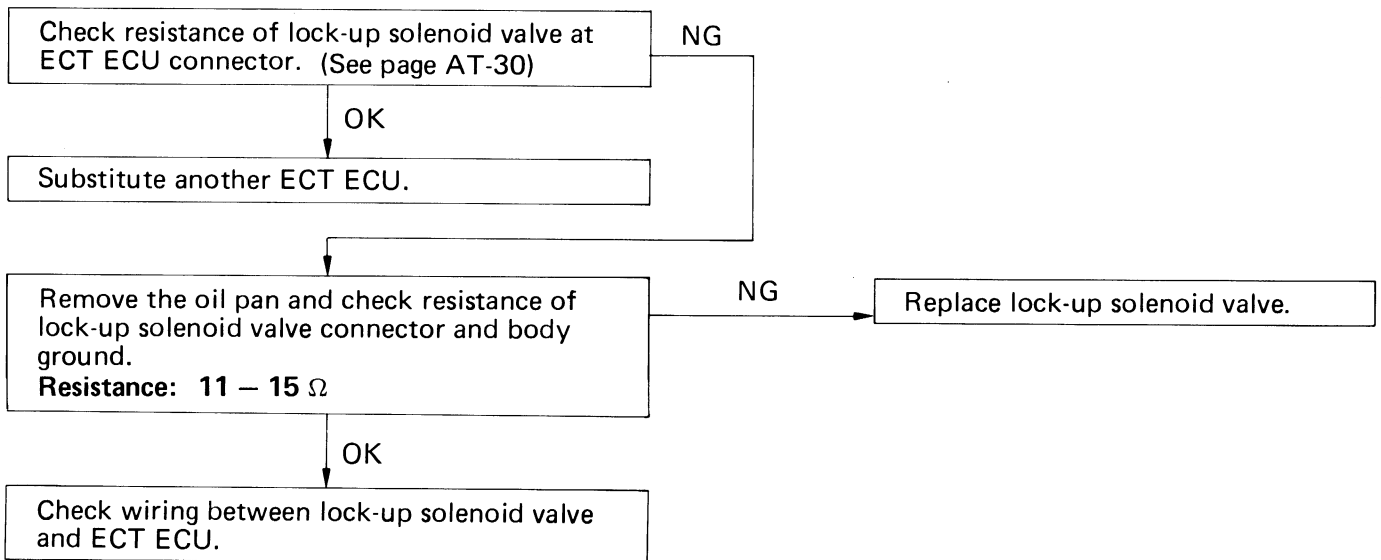

## Preliminary Check

### 1. CHECK FLUID LEVEL

#### HINT:

- The vehicle must have been driven so that the engine and transmission are at normal operating temperature. (Fluid temperature: 70 – 80°C or 158 – 176°F)
- Only use the COOL range on the dipstick as a rough reference when the fluid is replaced or the engine does not run.

- Park the vehicle on a level surface, set the parking brake.
- With the engine idling, shift the shift lever into all positions from P to L position and return to P position.
- Pull out the transmission dipstick and wipe it clean.
- Push it back fully into the tube.
- Pull it out and check that the fluid level is in the HOT range.

If the level is at the low side, add fluid.

**Fluid type: ATF DEXRON® II**

**NOTICE: Do not overfill.**

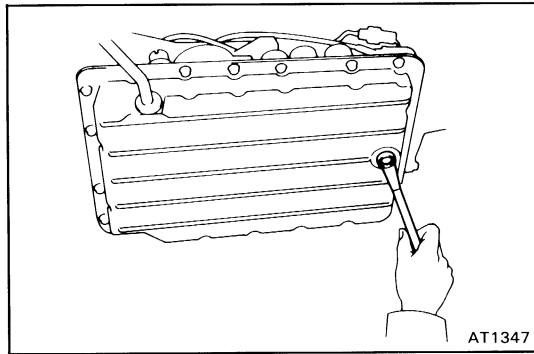
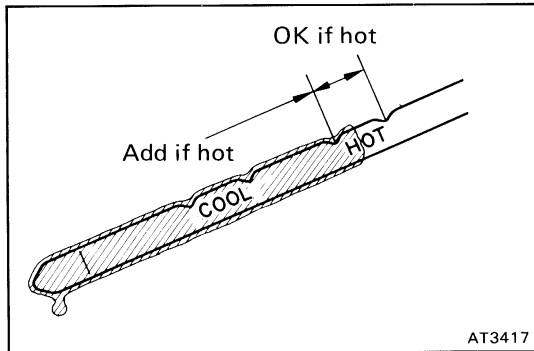

### 2. CHECK FLUID CONDITION

If the fluid smells burnt or is black, replace it as following procedures.

- Remove the drain plug and drain the fluid.
- Reinstall the drain plug securely.
- With the engine OFF, add new fluid through the oil filler tube.

**Fluid type: ATF DEXRON® II**

**Capacity:**

**Total: 7.2 liters (7.6 US qts, 6.3 Imp.qts)**

**Drain and refill: 1.6 liters (1.7 US qts, 1.4 Imp.qts)**

- Start the engine and shift the shift lever into all positions from P to L position and then shift into P position.
- With the engine idling, check the fluid level. Add fluid up to the COOL level on the dipstick.

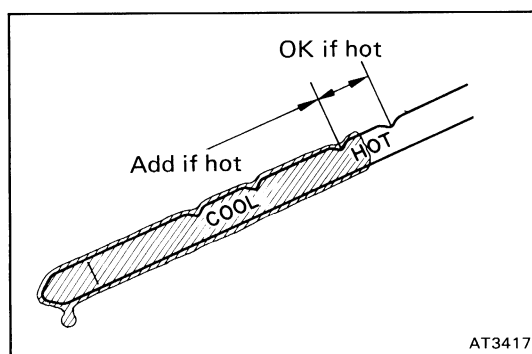
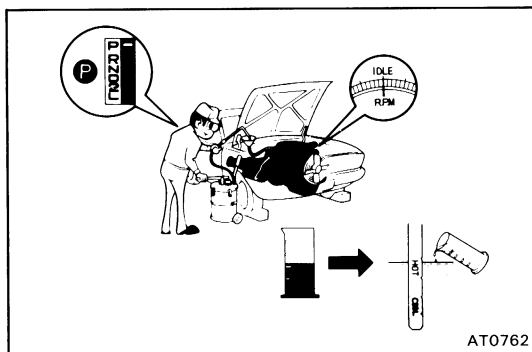

- Check the fluid level with the normal operating temperature (70 – 80°C or 158 – 176°F) and add as necessary.

**NOTICE: Do not overfill.**

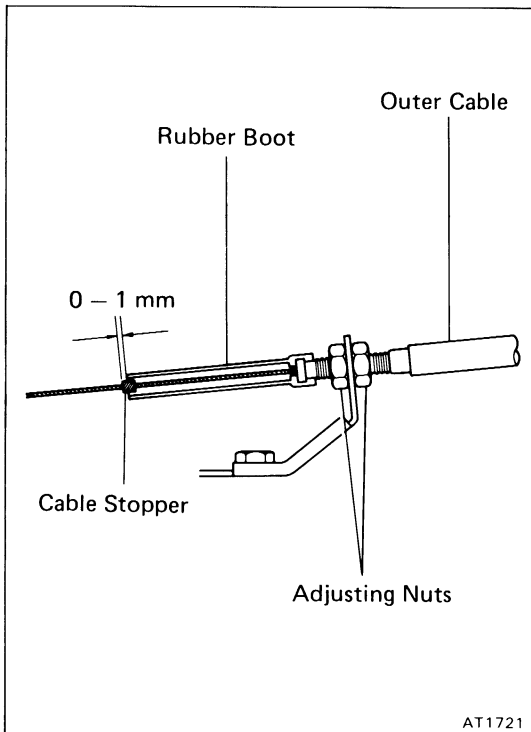

**3. INSPECT THROTTLE CABLE**

(a) Depress the accelerator pedal all the way and check that the throttle valve opens fully.

**HINT:** If the valve does not open fully, adjust the accelerator cable.

(b) Fully depress the accelerator pedal.

(c) Measure the distance between the end of the boot and stopper on the cable.

**Standard distance: 0 - 1 mm (0 - 0.04 in.)**

If the distance is not standard, adjust the cable by the adjusting nuts.

**4. INSPECT SHIFT LEVER POSITION**

When shifting the shift lever from the N position to other positions, check that the lever can be shifted smoothly and accurately to each position and that the position indicator correctly indicates the position.

If the indicator is not aligned with the correct position, carry out the following adjustment procedures.

- (a) Loosen the nut on the shift lever.
- (b) Push the control shaft lever fully rearward.
- (c) Return the control shaft lever two notches to N position.
- (d) Set the shift lever to N position.
- (e) While holding the shift lever lightly toward the R position side, tighten the shift lever nut.
- (f) Start the engine and make sure that the vehicle moves forward when shifting the lever from the N to D position and reverse when shifting it to the R position.

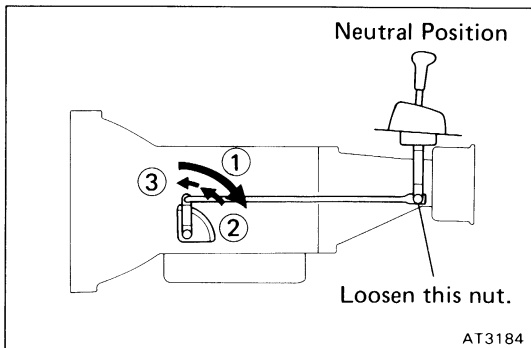

**5. INSPECT NEUTRAL START SWITCH**

Check that the engine can be started with the shift lever only in the N or P position, but not in other positions.

If not as stated above, carry out the following adjustment procedures.

- (a) Loosen the neutral start switch bolt and set the shift lever to the N position.
- (b) Align the groove and neutral basic line.
- (c) Hold in position and tighten the bolt.

**Torque: 130 kg-cm (9 ft-lb, 13 N·m)**

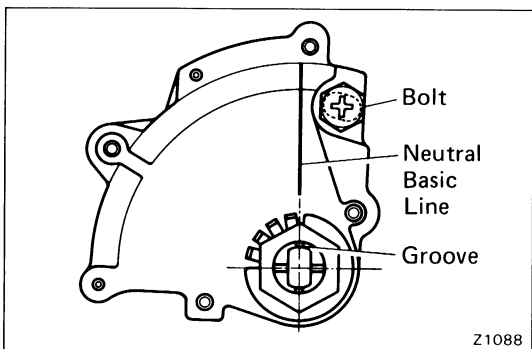

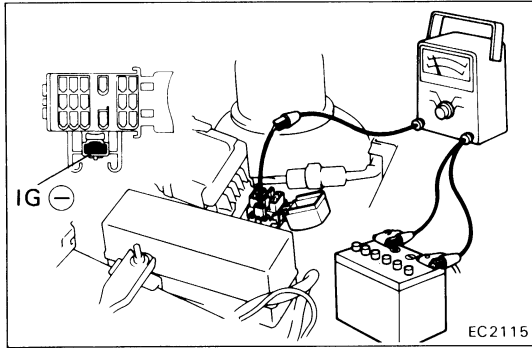

### 6. INSPECT IDLE SPEED (N RANGE)

Connect a tachometer test probe to the check connector terminal IG ⊖, inspect the idle speed.

Idle speed: 7M-GE 700 rpm  
7M-GTE 650 rpm

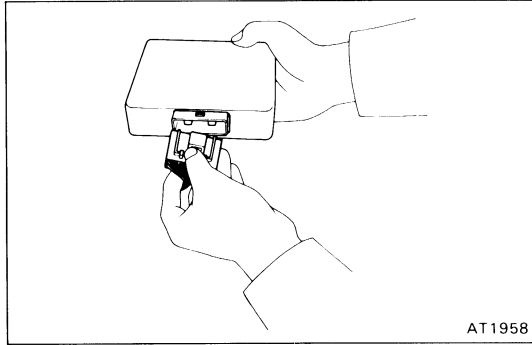

## Manual Shifting Test

**HINT:** With this test, it can be determined whether the trouble lies within the electrical circuit or is a mechanical problem in the transmission.

### 1. DISCONNECT ECT ECU CONNECTOR

- Remove the cowl side trim of passenger side.
- With the engine OFF, disconnect the ECT ECU connector.

### 2. INSPECT MANUAL DRIVING OPERATION

Check that the shift and gear positions correspond with the table below.

Shift position	D range	2 range	L range	R range	P range
Gear position	O/D	3rd	1st	Reverse	Pawl Lock

**HINT:** If the L, 2 and D range gear positions are difficult to distinguish, perform the following road test.

- While driving, shift through the L, 2 and D ranges. Check that the gear change corresponds to the shift position.

If any abnormality is found in the above test, the problem lies in transmission itself.

### 3. CONNECT ECT ECU CONNECTOR

- Connect the ECT ECU connector.
- Install the cowl side trim of passenger side.

# Electronic Control System

## PRECAUTION

Do not open the cover or the case of the ECU and various computer unless absolutely necessary. (If the IC terminals are touched, the IC may be destroyed by static electricity.)

## ELECTRONIC CONTROL CIRCUIT

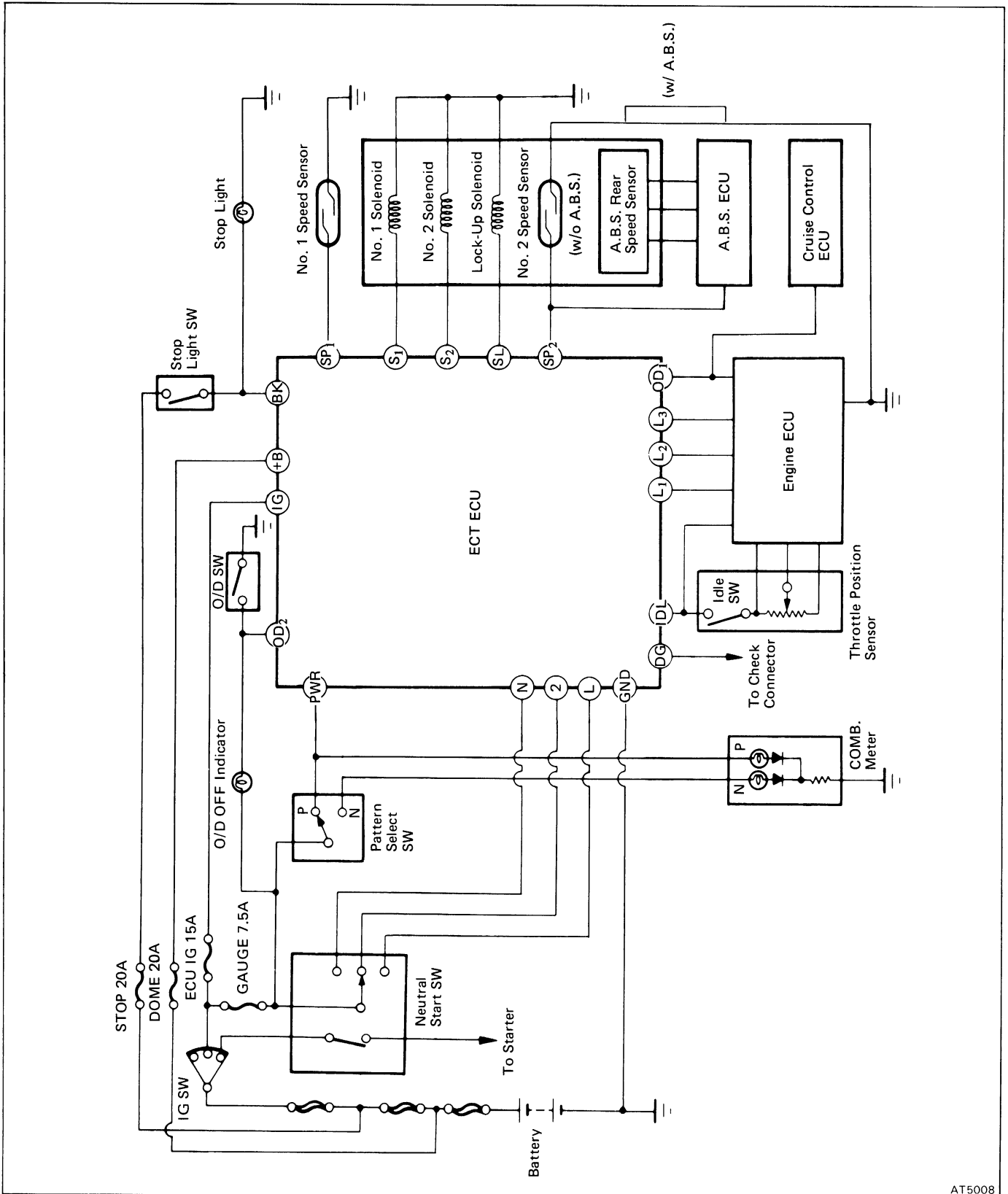

### ELECTRONIC CONTROL COMPONENTS

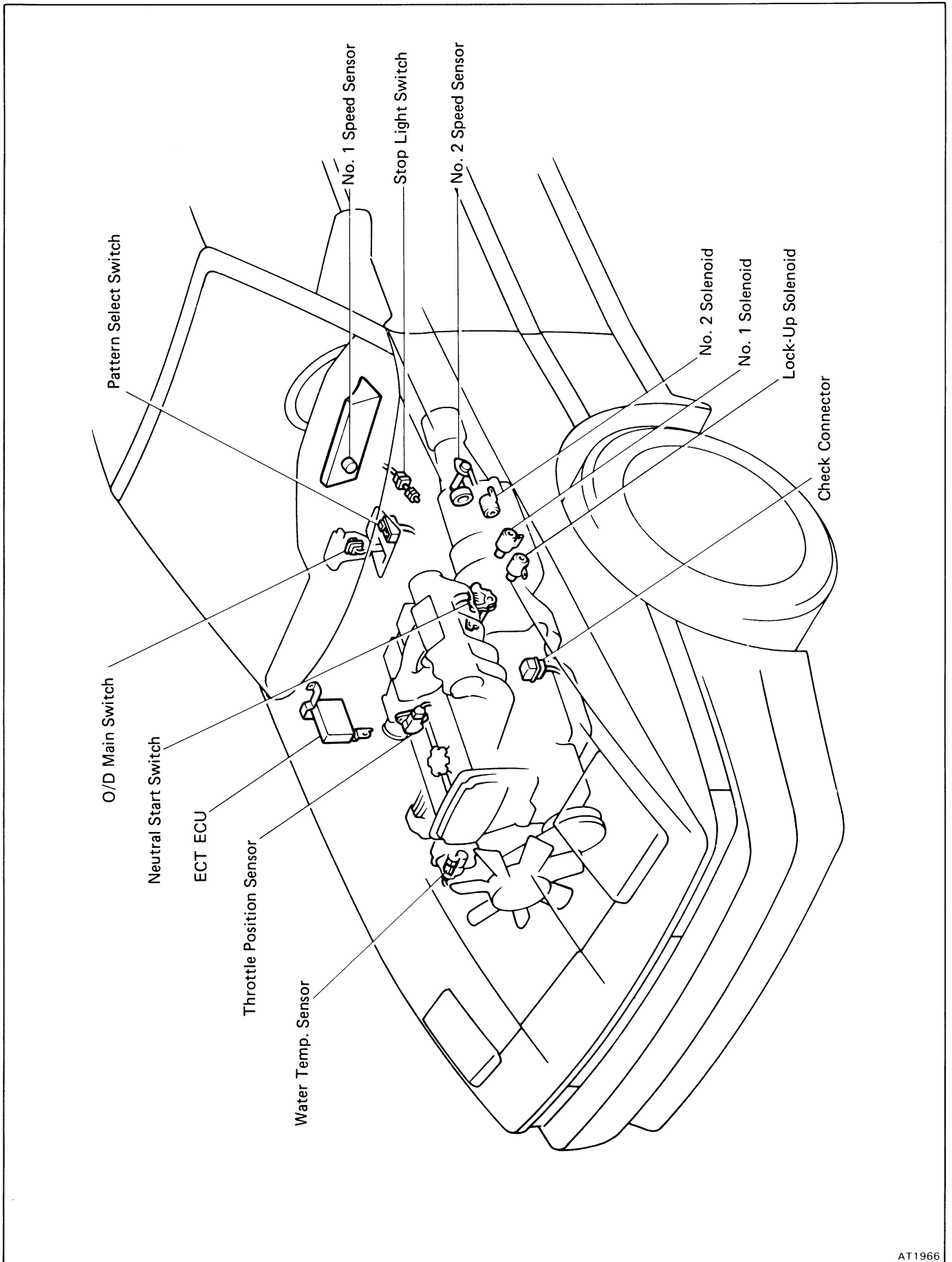

**TROUBLESHOOTING FLOW-CHART**

**Trouble No. 1 No Shifting**

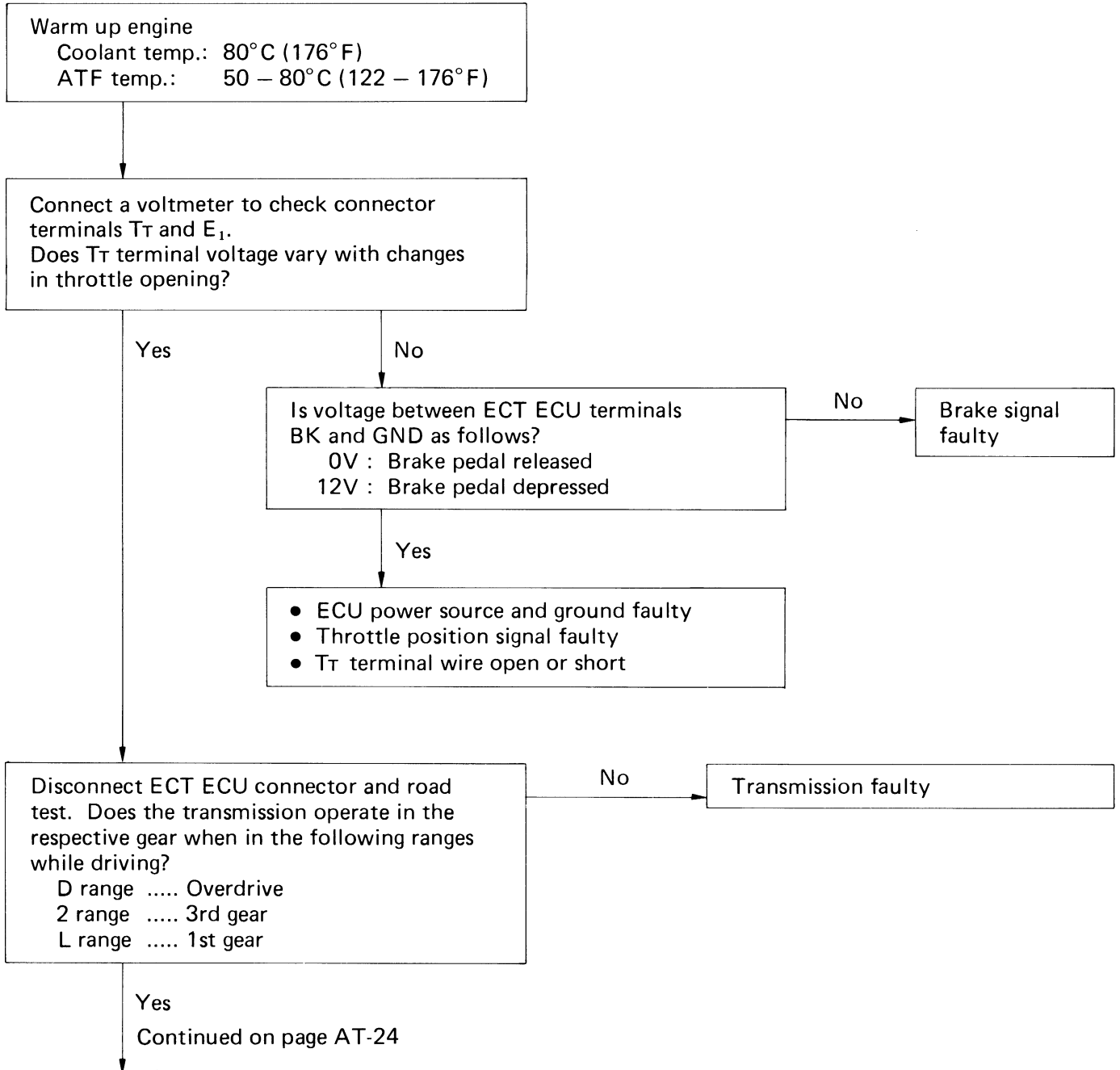

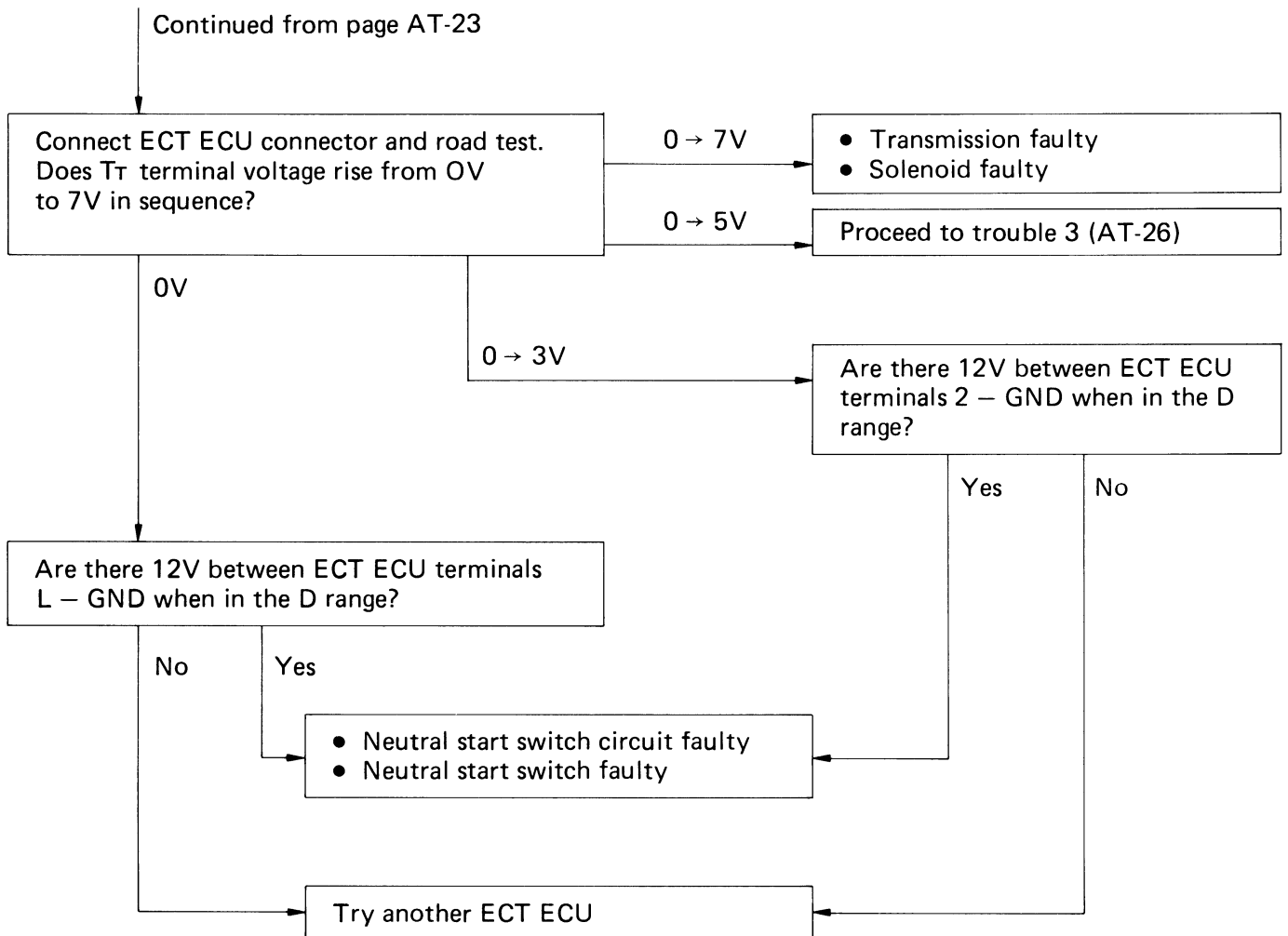



**Trouble No. 2 Shift point too high or too low**

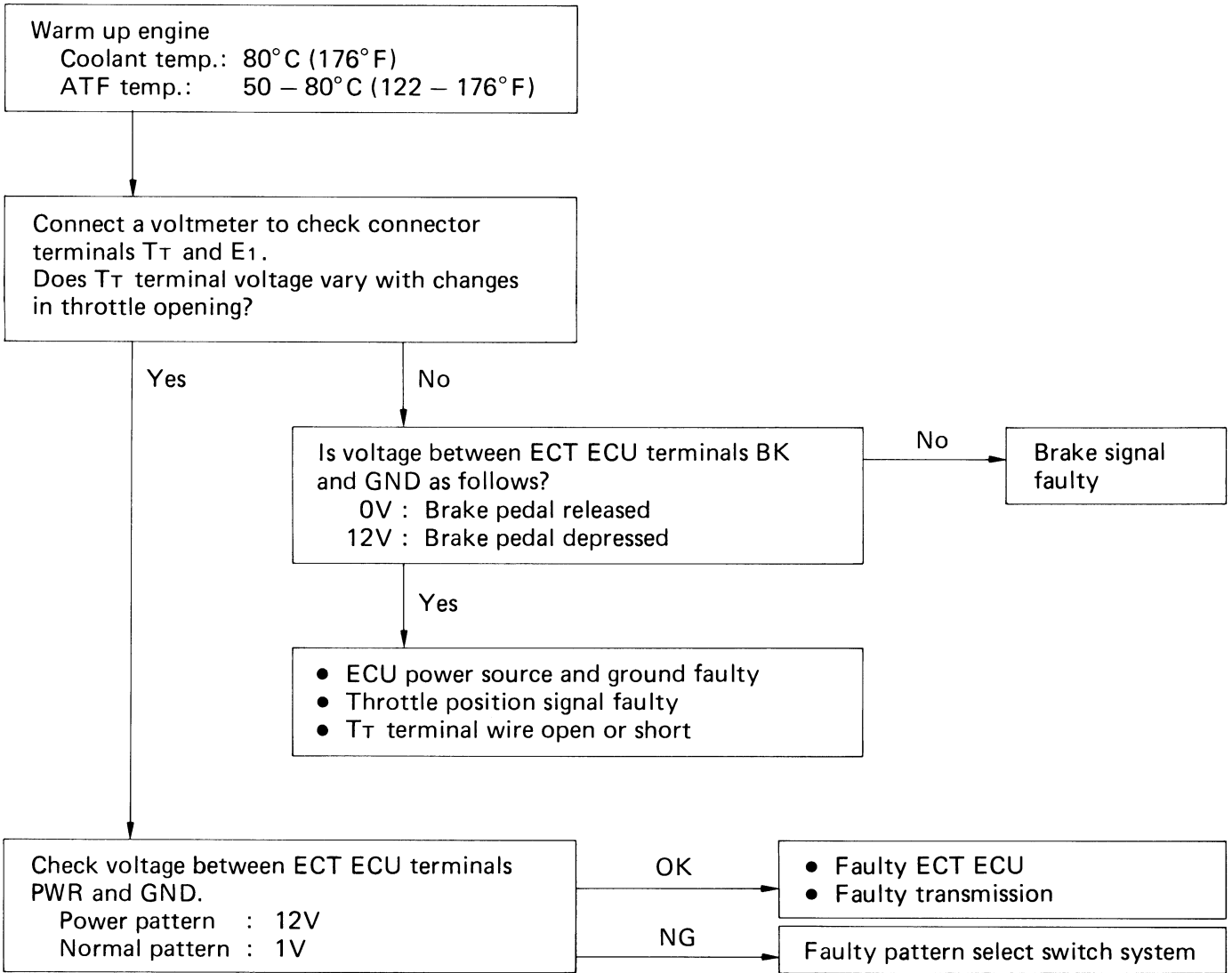

**Trouble No. 3 No up-shift to overdrive (After warm-up)**

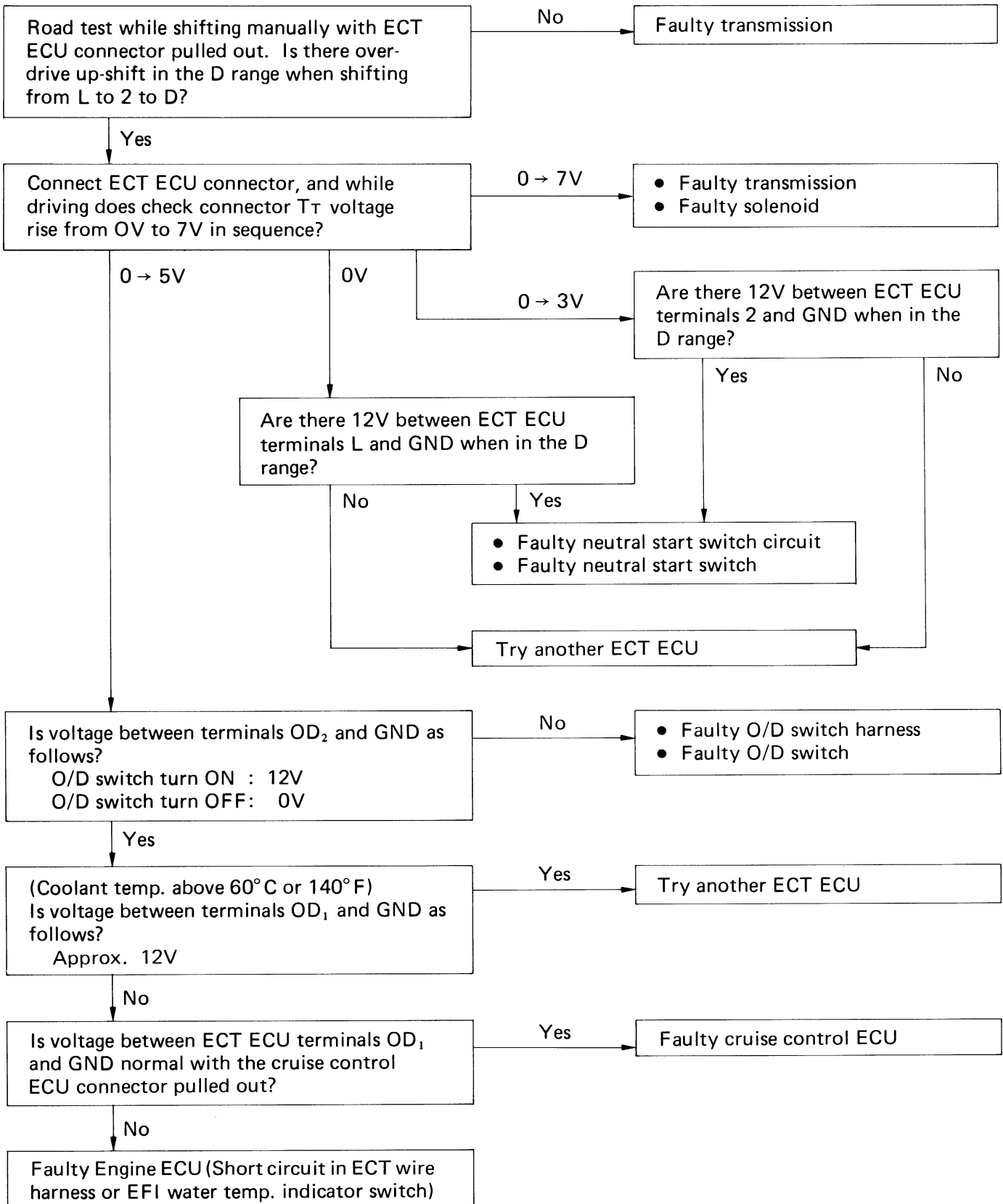

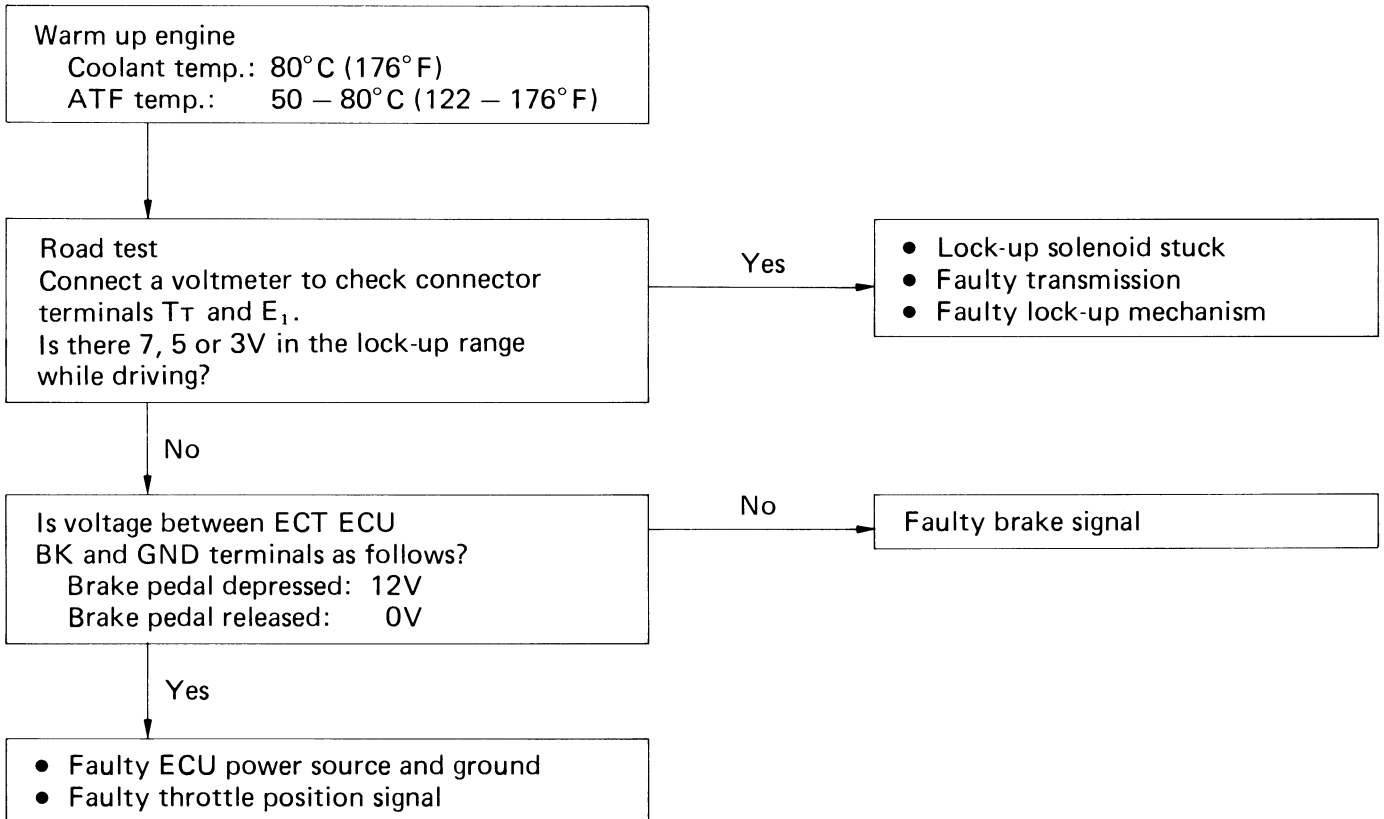
**Trouble No. 4 No lock-up (After warm-up)**

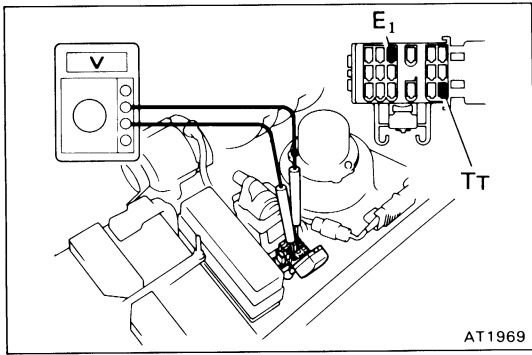

### INSPECTION OF T<sub>T</sub> TERMINAL VOLTAGE

#### 1. INSPECT THROTTLE POSITION SENSOR SIGNAL

- (a) Turn the ignition switch to ON. Do not start the engine.
- (b) Connect a voltmeter to check connector terminals T<sub>T</sub> and E<sub>1</sub>.

- (c) While slowly depressing the accelerator pedal, check that T<sub>T</sub> terminal voltage rises in sequence.

If the voltage does not change in proportion to the throttle opening angle, there is a malfunction in the throttle position sensor or circuit.

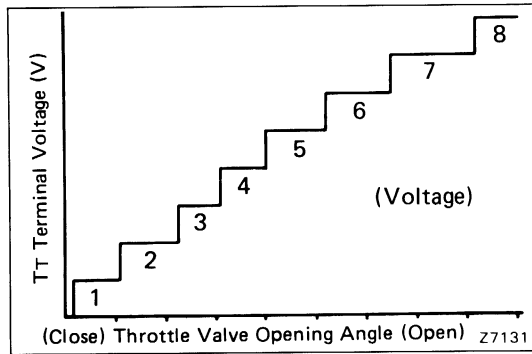

#### 2. INSPECT BRAKE SIGNAL

- (a) Depress the accelerator pedal until the T<sub>T</sub> terminal indicates 8V.
- (b) Depress the brake pedal and check the voltage reading from the T<sub>T</sub> terminal.  
 Brake pedal depressed..... 0V  
 Brake pedal released..... 8V

If not as indicated, there is a malfunction in either the stop light switch or circuit.

#### 3. INSPECT EACH UP-SHIFT POSITION

- (a) Warm up the engine.  
**Coolant temperature: 80°C (176°F)**
- (b) Turn the O/D switch to "ON".
- (c) Place the pattern select switch in "Normal" and the shift lever into the D range.
- (d) During a road test (above 10 km/h or 6 mph) check that voltage at the T<sub>T</sub> terminal is as indicated below for each up-shift position.

If the voltage rises from 0V to 7V in the sequence shown, the control system is okay.

The chart on the left shows the voltmeter reading and corresponding gears.

**HINT:** Determine the gear position by a light shock or change in engine rpm when shifting. The lock-up clutch will turn ON only infrequently during normal 2nd and 3rd gear operation. To trigger this action, press the accelerator pedal to 50% or more of its stroke. At less than 50%, the voltage may change in the sequence 2V — 4V — 6V — 7V.

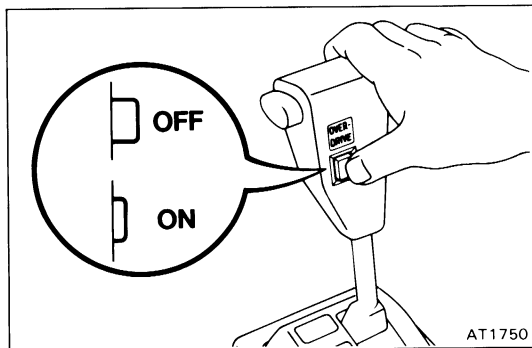

T <sub>T</sub> Terminal (V)	Gear Position
0	1st
2	2nd
3	2nd Lock-up
4	3rd
5	3rd Lock-up
6	O/D
7	O/D Lock-up

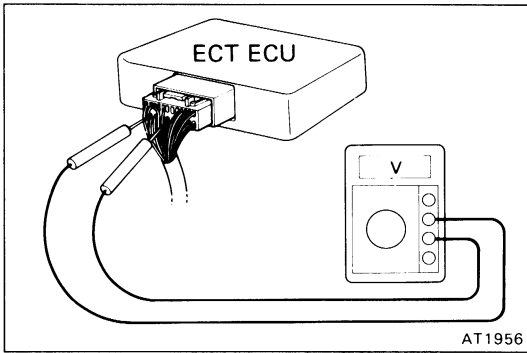

### INSPECTION OF ELECTRONIC CONTROL COMPONENTS

#### 1. INSPECT VOLTAGE OF ECT ECU CONNECTOR

- (a) Remove the cowl side trim of passenger side.
- (b) Turn on the ignition switch.
- (c) Measure the voltage at each terminal.

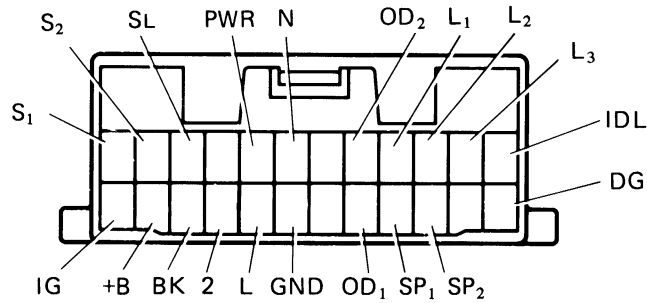

R-24-2

Terminal	Measuring condition	Voltage (V)	
L <sub>1</sub> — GND	Throttle valve fully closed	12	
	Throttle valve fully closed to fully open	12 to 0	
	Throttle valve fully open	0	
L <sub>2</sub> — GND	Throttle valve fully closed	12	
	Throttle valve fully closed to fully open	12 to 0 to 12	
	Throttle valve fully open	12	
L <sub>3</sub> — GND	Throttle valve fully closed	12	
	Throttle valve fully closed to fully open	12 to 0 to 12 to 0 to 12	
	Throttle valve fully open	12	
IDL — GND	Throttle valve fully closed	0	
	Throttle valve opening above 1.5°	12	
SP <sub>1</sub> — GND	Cruise control main switch OFF	Standing still	5 or 0
		Engine running, vehicle moving	2.5
BK — GND	When brake pedal is depressed	12	
	When brake pedal is not depressed	0	
2 — GND	"2" range	10 — 16	
	Except "2" range	0 — 2	
L — GND	"L" range	10 — 16	
	Except "L" range	0 — 2	
N — GND	"N" range	10 — 16	
	Except "N" range	0 — 2	

Terminal	Measuring condition	Voltage (V)
S <sub>1</sub> – GND	–	12
S <sub>2</sub> , S <sub>L</sub> – GND	–	0
OD <sub>1</sub> – GND	Coolant temp. below 60°C (140°F)	0
	Coolant temp. above 60°C (140°F)	12
OD <sub>2</sub> – GND	O/D main switch turned ON	12
	O/D main switch turned OFF	0
IG – GND	Ignition switch ON	12
SP <sub>2</sub> – GND	Standing still	5 or 0
	Vehicle moving	4
PWR – GND	PWR pattern	12
	NORM pattern	0 – 2
+B – GND	–	12

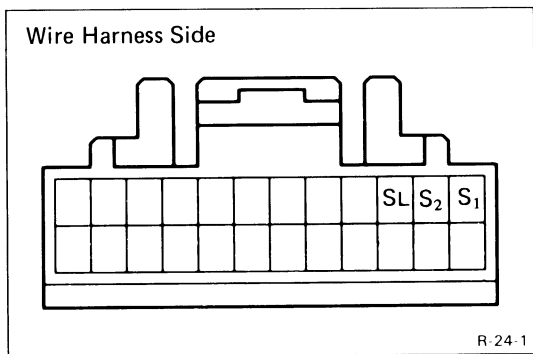

**2. INSPECT SOLENOID**

- (a) Disconnect the connector from the ECT ECU.
- (b) Measure the resistance between S<sub>1</sub>, S<sub>2</sub>, S<sub>L</sub> and ground.

**STD: 11 – 15 Ω**

- (c) Apply battery voltage to the solenoid. Check that an operation noise can be heard from the solenoid.

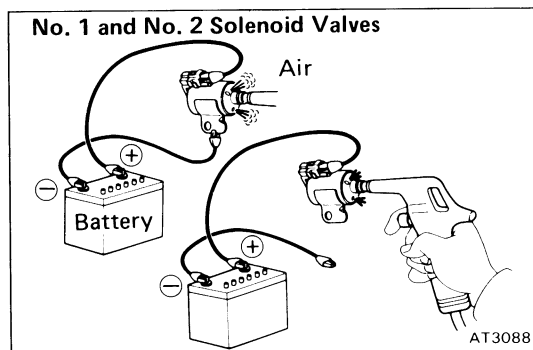

**3. CHECK SOLENOID SEALS**

If there is foreign material in the solenoid valve, there will be no fluid control even with solenoid operation.

- (a) Check No. 1 and No. 2 solenoid valves.
  - Check that the solenoid valve does not leak when low-pressure compressed air is applied.
  - When supply battery voltage to the solenoid, check that the solenoid valve opens.

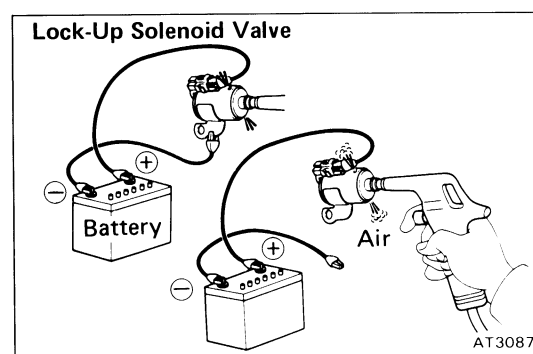

- (b) Check the lock-up solenoid valve.
  - Applying 5 kg/cm<sup>2</sup> (71 psi, 490 kPa) of compressed air, check that the solenoid valve opens.
  - When supply battery voltage to the solenoid, check that the solenoid valve does not leak the air.

If a malfunction is found during voltage inspection (step 1.), inspect the components listed below.

**4. INSPECT NEUTRAL START SWITCH**  
(See page AT-41)

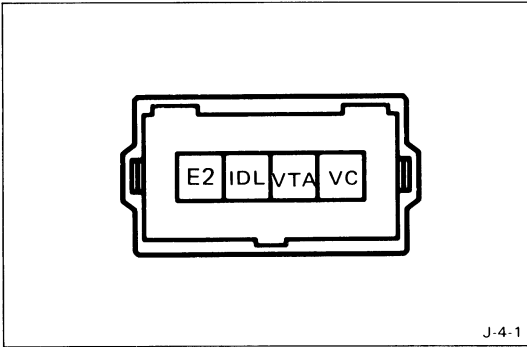

**5. INSPECT THROTTLE POSITION SENSOR**

Using an ohmmeter, check the resistance between each terminal.

Terminal	Throttle valve condition	Resistance (kΩ)
IDL — E <sub>2</sub>	Fully closed	0 — 2.3
	Open	Infinity
VC — E <sub>2</sub>	—	3 — 7
VTA — E <sub>2</sub>	Fully closed	0.2 — 0.8
	Fully open	3 — 7

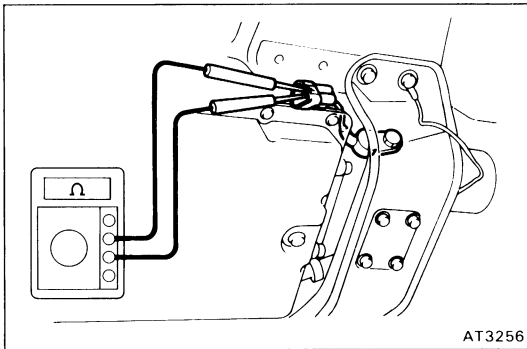

**6. (w/o A.B.S.) INSPECT NO. 2 SPEED SENSOR**

- (a) Jack up the rear wheel on one side.
- (b) Connect an ohmmeter between the connector and ground.
- (c) Spin the wheel and check that the meter needle deflects from 0 Ω to ∞ Ω.

HINT: For vehicles with A.B.S., the A.B.S. rear speed sensor is used by the ECT in stead of the No. 2 speed sensor. See page BR-46 for the vehicle with A.B.S.

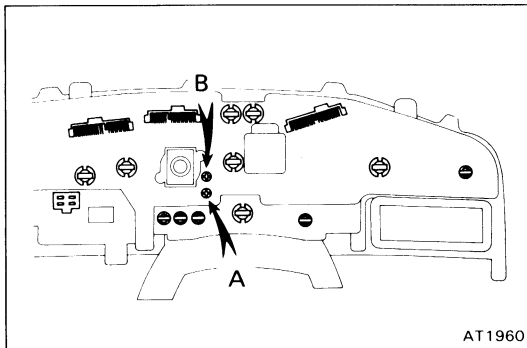

**7. INSPECT NO. 1 SPEED SENSOR IN COMBINATION METER**

- (a) Remove the combination meter.
- (b) Connect an ohmmeter between terminals A and B.
- (c) Revolve the meter shaft and check that the meter needle repeatedly deflects from 0 Ω to ∞ Ω.

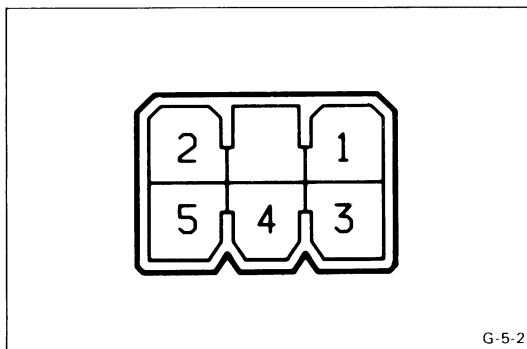

**8. INSPECT PATTERN SELECT SWITCH**

Inspect that there is continuity between 2 and each terminal.

HINT: As there are diodes inside, be careful of the tester probe polarity.

Terminal	2	3	4
Pattern			
PWR	○—○		
NORM	○—○		○—○

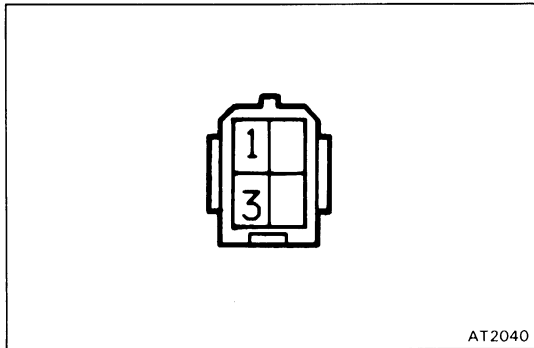

### 9. INSPECT O/D SWITCH

Inspect that there is continuity between terminals 1 and 3.

SW position	Terminal	
	1	3
ON		
OFF	○	○

### 10. INSPECT WATER TEMPERATURE SENSOR (See page FI-101)

## Mechanical System Tests

### STALL TEST

The object of this test is to check the overall performance of the transmission and engine by measuring the stall speeds in the D and R ranges.

#### NOTICE:

- Perform the test at normal operating fluid temperature (50 — 80°C or 122 — 176°F).
- Do not continuously run this test longer than 5 seconds.
- To ensure safety, conduct this test in a wide, clear, level area, which provides good traction.
- The stall test should always be carried out in pairs. One should observe the conditions of wheels or wheel stoppers outside the vehicle while the other is performing the test.

#### MEASURE STALL SPEED

- Chock the four wheels.
- Connect a tachometer to the engine.
- Fully apply the parking brake.
- Keep your left foot pressed firmly on the brake pedal.
- Start the engine.
- Shift into the D range. Step all the way down on the accelerator pedal with your right foot. Quickly read the stall speed at this time.

**NOTICE:** Release the accelerator pedal and stop test if the rear wheels begin to rotate before the engine speed reaches specified stall speed.

Stall speed: 7M-GE 2,200 ± 150 rpm  
7M-GTE 2,500 ± 150 rpm

- Perform the same test in R range.

#### EVALUATION

- Usually the rear wheels begin to rotate when the engine speed (depending on the brake force) reaches approximately 1,800 — 1,900 rpm. If so, the stall speed may be within the standard range. As a result, it can be assumed that there are no problems regarding the stall test explained in the following (b), (c), (d) and (e).
  - If the stall speed is the same for both ranges without the rear wheels rotating but lower than specified value:
    - Engine output may be insufficient
    - Stator one-way clutch is not operating properly
- HINT:** If more than 600 rpm below the specified value, the torque converter could be faulty.
- If the stall speed in D range is higher than specified without the rear wheels rotating:
    - Line pressure too low
    - Forward clutch slipping
    - No. 2 one-way clutch not operating properly
    - O/D one-way clutch not operating properly



- (d) If the stall speed in R range is higher than specified without the rear wheels rotating:
- Line pressure too low
  - Direct clutch slipping
  - First and reverse brake slipping
  - O/D one-way clutch not operating properly
- (e) If the stall speed in both R and D ranges are higher than specified without the rear wheels rotating:
- Line pressure too low
  - Improper fluid level
  - O/D one-way clutch not operating properly

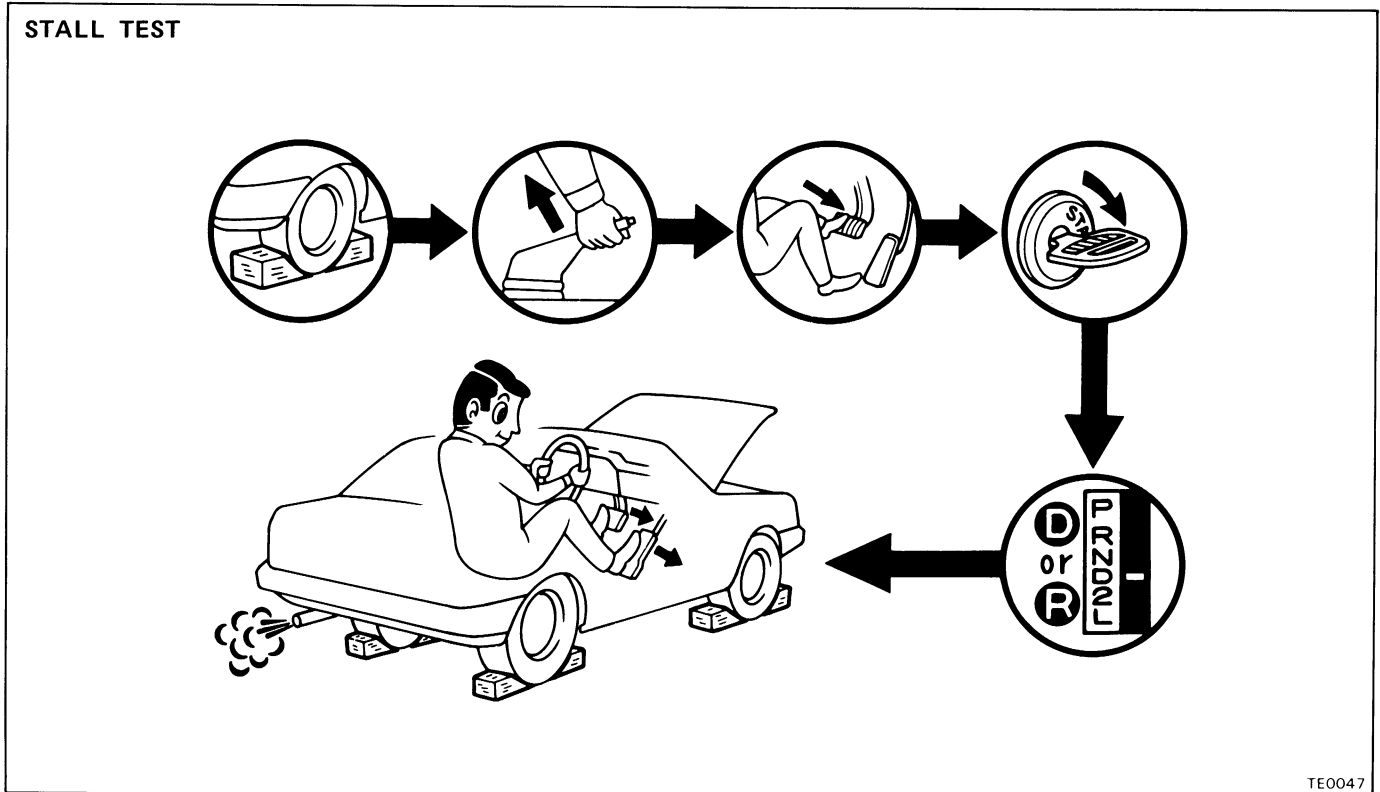

## TIME LAG TEST

When the shift lever is shifted while the engine is idling, there will be a certain time elapse or lag before the shock can be felt. This is used for checking the condition of the O/D direct clutch, forward clutch, direct clutch and first and reverse brake.

### NOTICE:

- Perform the test at normal operating fluid temperature (50 — 80°C or 122 — 176°F).
- Be sure to allow one minute interval between tests.
- Make three measurements and take the average value.

## MEASURE TIME LAG

- (a) Fully apply the parking brake.
- (b) Start the engine and check the idle speed.

**Idle speed:** 7M-GE 700 rpm  
(N range) 7M-GTE 650 rpm

- (c) Shift the shift lever from N to D position. Using a stop watch, measure the time it takes from shifting the lever until the shock is felt.

**Time lag: Less than 1.2 seconds**

- (d) In same manner, measure the time lag for N → R.

**Time lag: Less than 1.5 seconds**

## EVALUATION

- (a) If N → D time lag is longer than specified:
- Line pressure too low
  - Forward clutch worn
  - O/D one-way clutch not operating properly
- (b) If N → R time lag is longer than specified:
- Line pressure too low
  - Direct clutch worn
  - First and reverse brake worn
  - O/D one-way clutch not operating properly

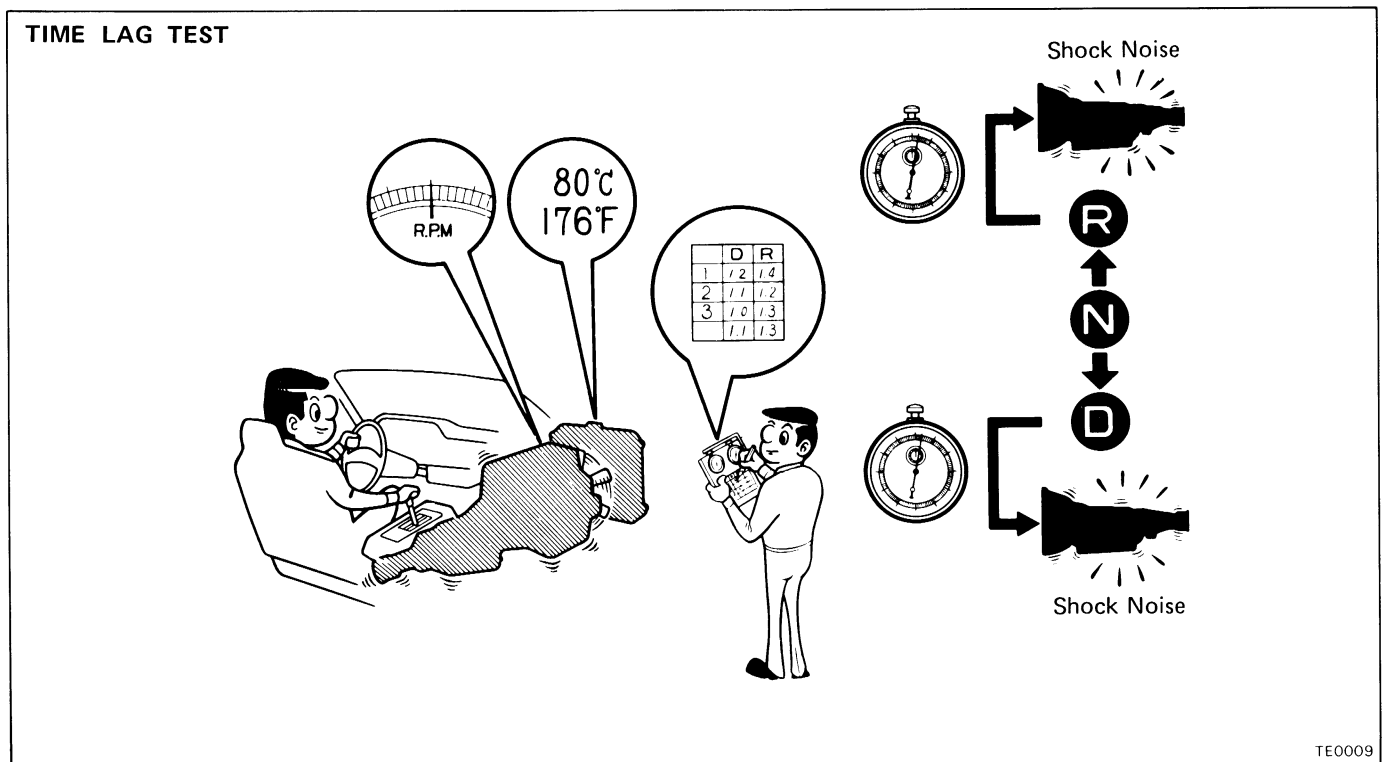

## HYDRAULIC TEST

## PREPARATION

- (a) Warm up the transmission fluid.
- (b) Remove the transmission case test plug and connect the hydraulic pressure gauge.  
SST 09992-00094 (Oil pressure gauge)

## NOTICE:

- Perform the test at normal operating fluid temperature (50 — 80°C or 122 — 176°F).
- The line pressure test should always be carried out in pairs. One should observe the conditions of wheels or wheel stoppers outside the vehicle while the other is performing the test.

## MEASURE LINE PRESSURE

- (a) Fully apply the parking brake and chock the four wheels.
- (b) Start the engine and check idling rpm.
- (c) Keep your left foot pressed firmly on the brake pedal and shift into D range.
- (d) Measure the line pressure when the engine is idling.
- (e) Press the accelerator pedal all the way down. Quickly read the highest line pressure when engine speed reaches approximately 1,700 rpm.

**NOTICE:** Release the accelerator pedal and stop test if the rear wheels begin to rotate. Usually the rear wheels begin to rotate when the engine speed (depending on the brake force) reaches approximately 1,800 — 1,900 rpm.

(f) In the same manner, perform the test in R range.

kg/cm<sup>2</sup> (psi, kPa)

Engine	D range		R range	
	Idling	Stall	Idling	Stall
7M-GE	3.5 – 4.3 (50 – 61, 343 – 422)	8.8 – 11.5 (125 – 164, 863 – 1,128)	4.9 – 6.1 (70 – 87, 481 – 598)	12.2 – 15.9 (174 – 226, 1,196 – 1,559)
7M-GTE	4.1 – 4.9 (58 – 70, 402 – 481)	12.3 – 15.0 (175 – 213, 1,206 – 1,471)	5.0 – 6.2 (71 – 88, 490 – 608)	15.1 – 18.8 (215 – 267, 1,481 – 1,844)

If the measured pressures are not up to specified values, recheck the throttle cable adjustment and perform a retest.

**EVALUATION**

- (a) If the measured values at all ranges are higher than specified:
  - Throttle cable out of adjustment
  - Throttle valve defective
  - Regulator valve defective
- (b) If the measured values at all ranges are lower than specified:
  - Throttle cable out of adjustment
  - Throttle valve defective
  - Regulator valve defective
  - Oil pump defective
  - O/D direct clutch defective
- (c) If pressure is low in the D range only:
  - D range circuit fluid leakage
  - Forward clutch defective
- (d) If pressure is low in the R range only:
  - R range circuit fluid leakage
  - Direct clutch defective
  - First and reverse brake defective

**HYDRAULIC TEST**

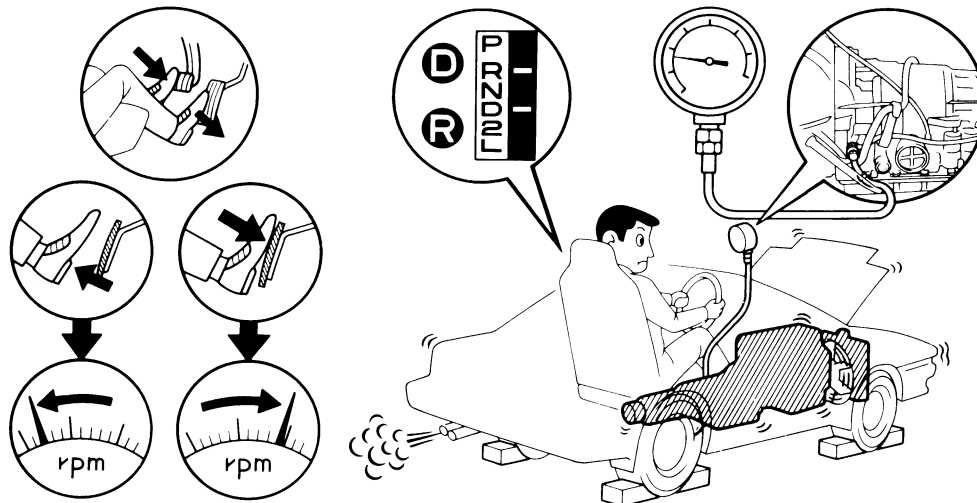

### ROAD TEST

**NOTICE:** Perform the test at normal operating fluid temperature (50 – 80°C or 122 – 176°F).

#### 1. D RANGE TEST IN NORM AND PWR PATTERN RANGES

Shift into the D range and hold the accelerator pedal constant at the full throttle valve opening position.

Check the following:

- (a) 1-2, 2-3 and 3-O/D up-shifts should take place, and shift points should conform to those shown in the automatic shift schedule.

Conduct a test under both Normal and Power patterns.

**HINT:**

- There is no O/D up-shift or lock-up when the coolant temp. is below 60°C (140°F) and speed is under 60 km/h (37 mph), or if there is a 10 km/h (6 mph) difference between the set cruise control speed.
- There is no 3rd up-shift or lock-up when coolant temp. is below 35°C (95°F) and speed is under 40 km/h (25 mph).

#### EVALUATION

- (1) If there is no 1 → 2 up-shift:
  - No. 2 solenoid is stuck
  - 1-2 shift valve is stuck
- (2) If there is no 2 → 3 up-shift:
  - No. 1 solenoid is stuck
  - 2-3 shift valve is stuck
- (3) If there is no 3 → O/D up-shift:
  - 3-4 shift valve is stuck
- (4) If the shift point is defective:
  - Throttle valve, 1-2 shift valve, 2-3 shift valve, 3-4 shift valve etc., are defective
- (5) If the lock-up is defective:
  - Lock-up solenoid is stuck
  - Lock-up relay valve is stuck

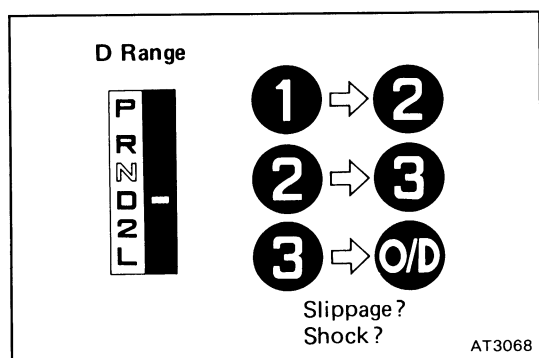
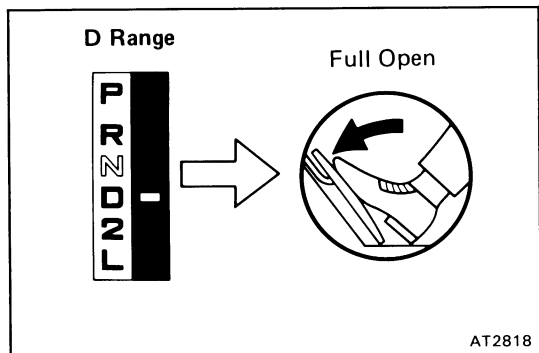

- (b) In the same manner, check the shock and slip at the 1 → 2, 2 → 3, and 3 → O/D up-shifts.

#### EVALUATION

- If the shock is excessive:
- Line pressure is too high
  - Accumulator is defective
  - Check ball is defective

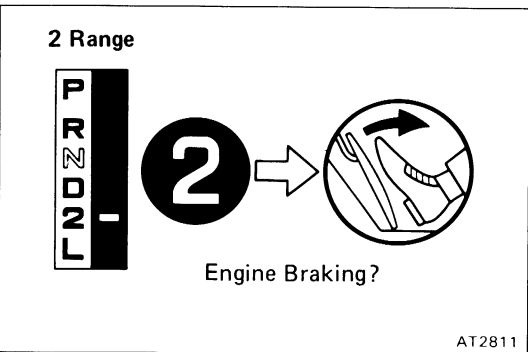
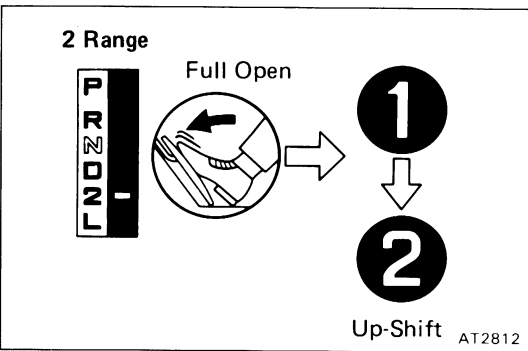
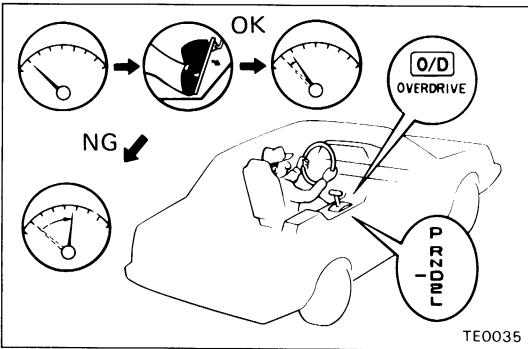
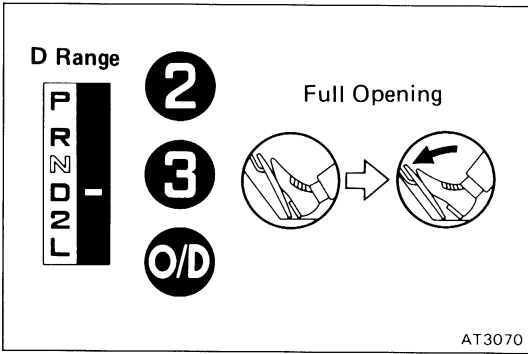
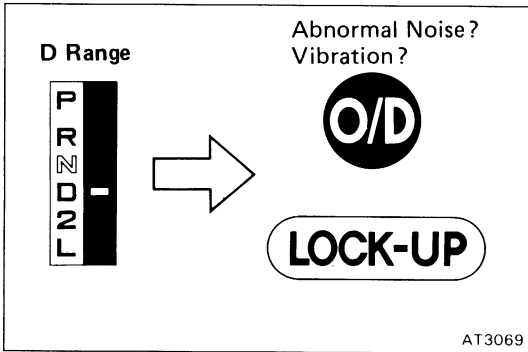

(c) Run at the D range lock-up or O/D gear and check for abnormal noise and vibration.

HINT: The check for the cause of abnormal noise and vibration must be made with extreme care as it could also be due to loss of balance in the propeller shaft, differential, torque converter, etc.

(d) While running in the D range, 2nd, 3rd and O/D gears, check to see that the possible kick-down vehicle speed limits for 2 → 1, 3 → 2 and O/D → 3 kick-downs conform to those indicated on the automatic shift schedule.

(e) Check for abnormal shock and slip at kick-down.

(f) Check for the lock-up mechanism.

- (1) Drive in D range, O/D gear, at a steady speed (lock-up ON) of about 75 km/h (47 mph).
- (2) Lightly depress the accelerator pedal and check that the engine rpm does not change abruptly.

If there is a big jump in engine rpm, there is no lock-up.

## 2. 2 RANGE TEST

Shift into the 2 range and, while driving with the accelerator pedal held constantly at the full throttle valve opening position, push in one of the pattern selectors and check on the following points.

(a) Check to see that the 1 → 2 up-shift takes place and that the shift point conforms to it shown on the automatic shift schedule.

HINT:

- There is no O/D up-shift and lock-up in the 2 range.
- To prevent overrun, the transmission up-shifts into 3rd gear at around 110 km/h (68 mph) [7M-GE] or 114 km/h (71 mph) [7M-GTE].

(b) While running in the 2 range and 2nd gear, release the accelerator pedal and check the engine braking effect.

### EVALUATION

If there is no engine braking effect:

- Second coast brake is defective

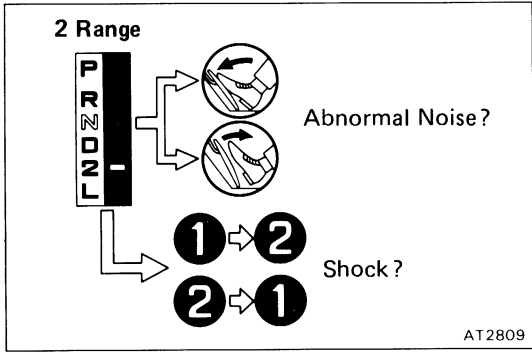

- (c) Check for abnormal noise at acceleration and deceleration, and for shock at up-shift and down-shift.

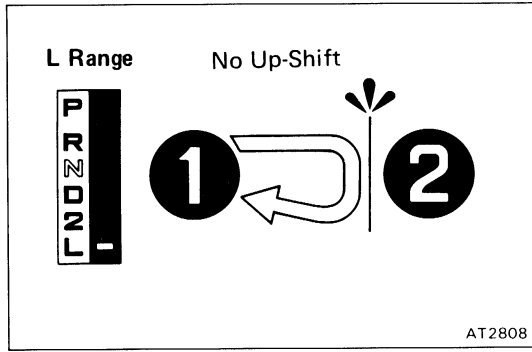

**3. L RANGE TEST**

- (a) While running in the L range, check to see that there is no up-shift to 2nd gear.

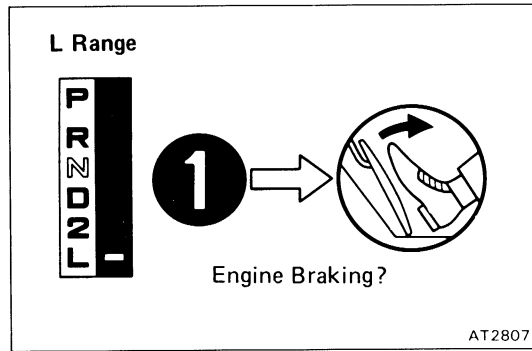

- (b) While running in the L range, release the accelerator pedal and check the engine braking effect.

**EVALUATION**

- If there is no engine braking effect:
- First and reverse brake is defective

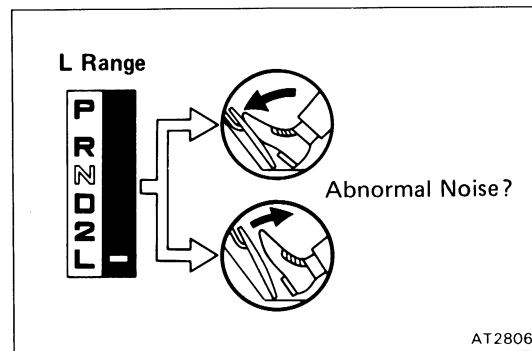

- (c) Check for abnormal noise during acceleration and deceleration.

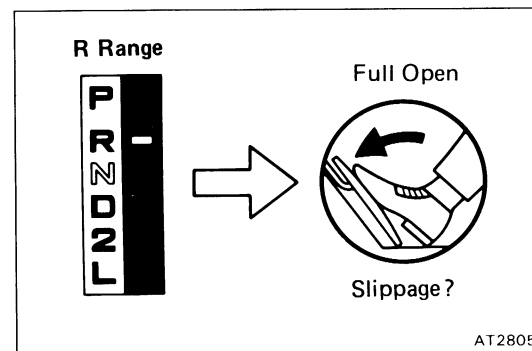

**4. R RANGE TEST**

- Shift into the R range and, while starting at full throttle, check for slippage.

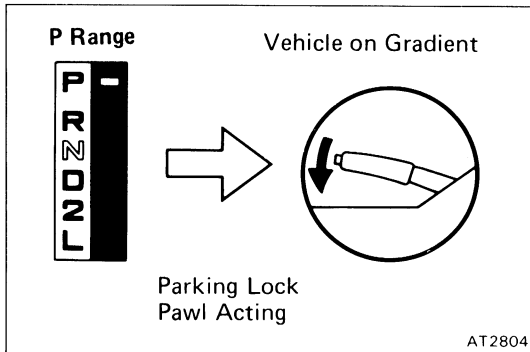

#### 5. P RANGE TEST

Stop the vehicle on a gradient (more than  $5^\circ$ ) and after shifting into the P range, release the parking brake.

Then check to see that the parking lock pawl holds the vehicle in place.

## Automatic Shift Schedule

### (7M-GE)

		Throttle valve fully open [ ] Fully closed						km/h (mph)	
		1 → 2	2 → 3	3 → O/D	[3 → O/D]	[O/D → 3]	O/D → 3	3 → 2	2 → 1
D range	NORM	44–48 (27–30)	92–99 (57–62)	146–155 (91–96)	[34–38] [(21–24)]	[25–29] [(16–18)]	141–150 (88–93)	85–93 (53–58)	39–43 (24–27)
	PWR	47–51 (29–32)	101–107 (63–66)	161–168 (100–104)	[41–45] [(25–28)]	[25–29] [(16–18)]	155–168 (96–101)	94–100 (58–62)	42–46 (26–29)
2 range	NORM	44–48 (27–30)	106–114 (66–71)	—	—	—	—	93–101 (58–63)	39–43 (24–27)
	PWR	—	—	—	—	—	—	—	46–50 (29–31)

		Throttle valve opening 5%						km/h (mph)	
		Lock-up ON			Lock-up OFF				
		2nd	*3rd	O/D	2nd	*3rd	O/D		
D range	NORM	—	73–78 (45–48)	58–62 (36–39)	—	68–72 (42–45)	55–58 (34–36)		
	PWR	—	73–78 (45–48)	63–66 (39–41)	—	68–72 (42–45)	57–61 (35–38)		

\* : O/D switch OFF

### (7M-GTE)

		Throttle valve fully open [ ] Fully closed						km/h (mph)	
		1 → 2	2 → 3	3 → O/D	[3 → O/D]	[O/D → 3]	O/D → 3	3 → 2	2 → 1
D range	NORM	40–44 (25–27)	94–99 (58–62)	149–159 (93–99)	[38–41] [(24–25)]	[28–32] [(17–20)]	143–153 (89–95)	86–94 (53–58)	34–39 (21–24)
	PWR	47–51 (30–32)	102–111 (63–69)	173–183 (108–114)	[45–50] [(28–31)]	[28–32] [(17–20)]	166–177 (103–110)	95–103 (59–64)	41–45 (25–28)
2 range	NORM	40–44 (25–27)	110–118 (68–73)	—	—	—	—	102–111 (63–69)	34–39 (21–24)
	PWR	—	—	—	—	—	—	—	51–56 (32–35)

		Throttle valve opening 5%						km/h (mph)	
		Lock-up ON			Lock-up OFF				
		2nd	*3rd	O/D	2nd	*3rd	O/D		
D range	NORM	—	80–85 (50–53)	60–65 (37–40)	—	74–79 (46–49)	57–62 (35–39)		
	PWR	—	80–85 (50–53)	69–73 (43–45)	—	74–79 (46–49)	63–67 (39–42)		

\* : O/D switch OFF

- HINT:
- (1) Lock-up will not occur in 2nd gear unless the throttle valve opening is greater than 35%.
  - (2) There is no lock-up in the 2 and L ranges.
  - (3) In the following cases, the lock-up will be released regardless of the lock-up pattern.
    - When the throttle is completely closed.
    - When the brake light switch is ON.





## ON-VEHICLE REPAIR

**HINT:** The components mentioned below can be replaced on the vehicle as they are without any necessity for removal of the transmission. For the respective operating procedures refer to the following pages:

Components	Removal	Installation	Remarks
Valve Body, Solenoid Valve	Steps 11 to 16 on pages AT-51 to 52	Steps 30 to 37 on pages AT-135 to 138	
Parking Lock Pawl	Step 32 on page AT-60	Step 8 on page AT-125	Remove the parking lock pawl after removing the valve body.
Extension Housing	AT-43 and Step 8 on page AT-50	AT-43 and Step 40 on page AT-139	For replacement of the oil seal, see page AT-118
Speedometer Driven Gear Oil Seal	See below	See below	

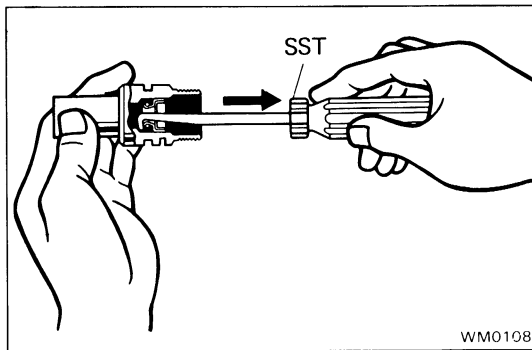

### REPLACEMENT OF SPEEDOMETER DRIVEN GEAR OIL SEAL

#### REMOVE SPEEDOMETER DRIVEN GEAR OIL SEAL

Using SST, remove the oil seal.

SST 09921-00010

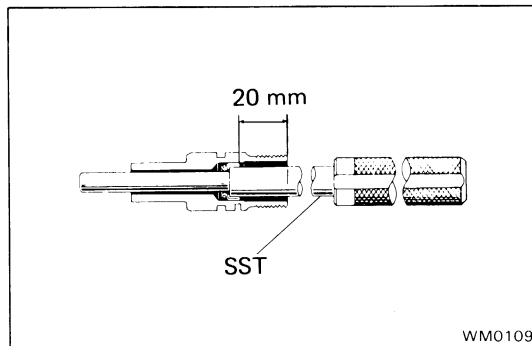

#### INSTALL SPEEDOMETER DRIVEN GEAR OIL SEAL

Using SST, install a new oil seal.

SST 09201-60011

Drive in depth: 20 mm (0.79 in.)

# REMOVAL AND INSTALLATION OF TRANSMISSION

Remove and install the parts as shown.

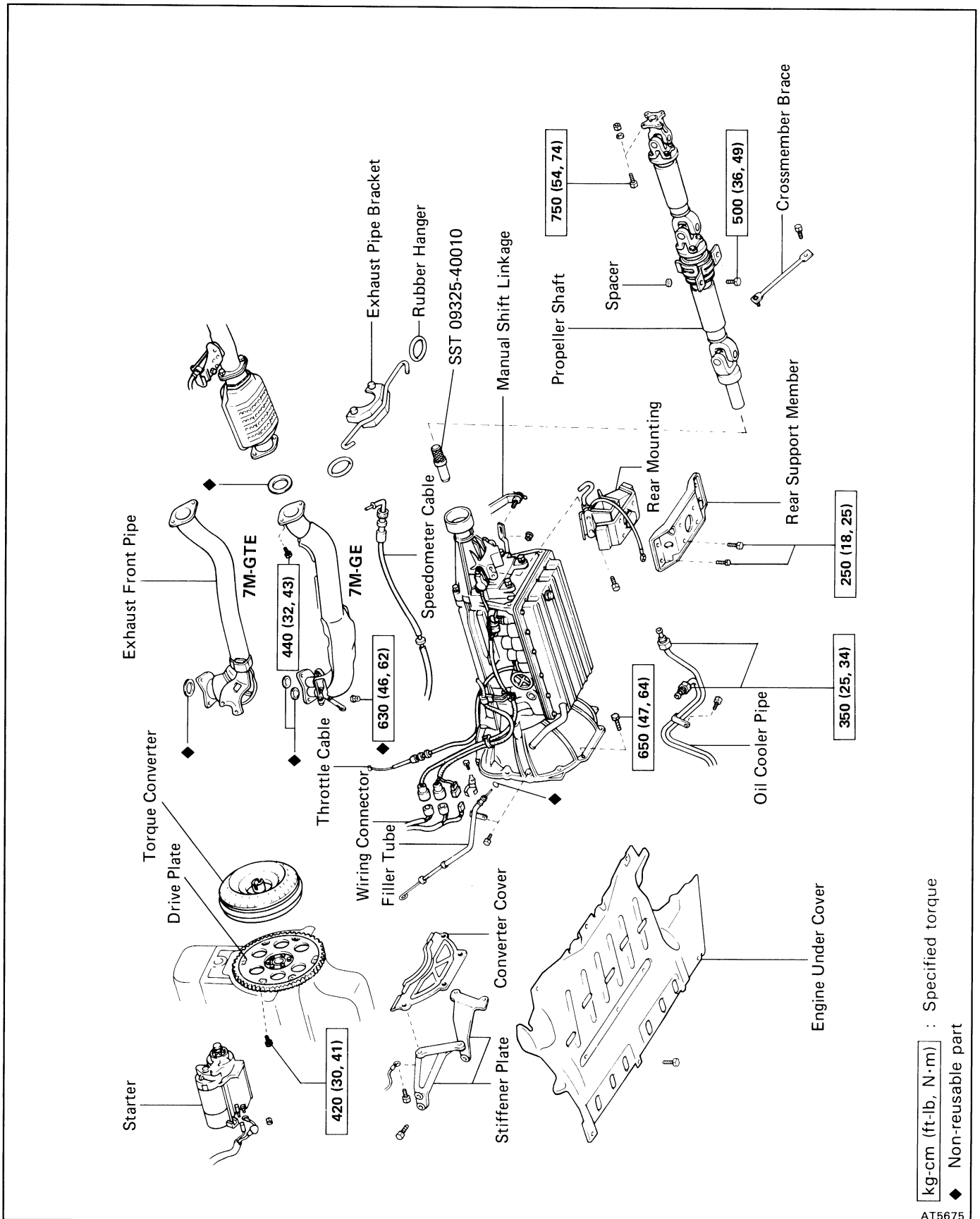

kg-cm (ft-lb, N·m) : Specified torque  
 ◆ Non-reusable part

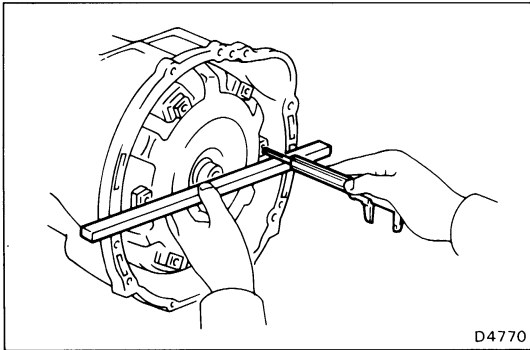

### (MAIN POINT OF INSTALLATION)

#### 1. CHECK TORQUE CONVERTER INSTALLATION

Using calipers and a straight edge, measure from the installed surface of the torque converter to the front surface of the transmission housing.

**Correct distance: 26.4 mm (1.039 in.)**

If the distance is less than the standard, check for an improper installation.

#### 2. ADJUST TRANSMISSION THROTTLE CABLE

(See page AT-19)

#### 3. FILL TRANSMISSION WITH ATF AND CHECK FLUID LEVEL

Fluid type: ATF DEXRON® II

**NOTICE: Do not overfill.**

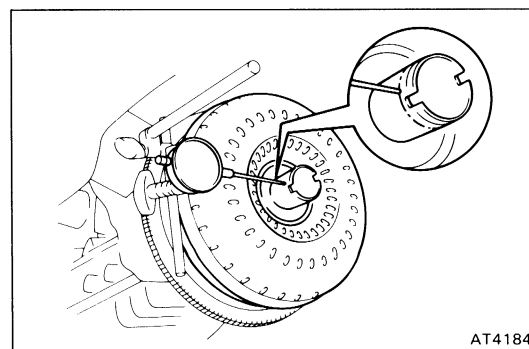
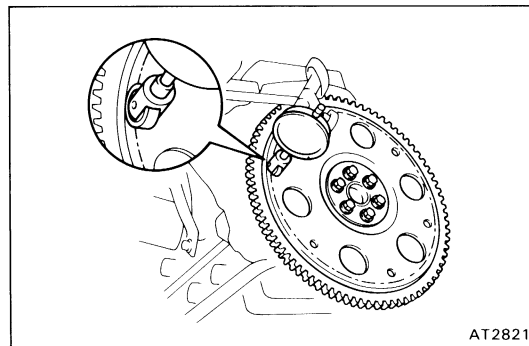
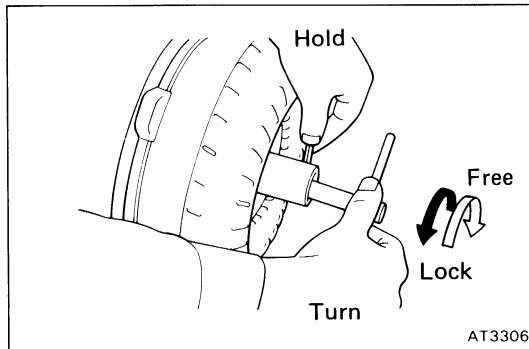
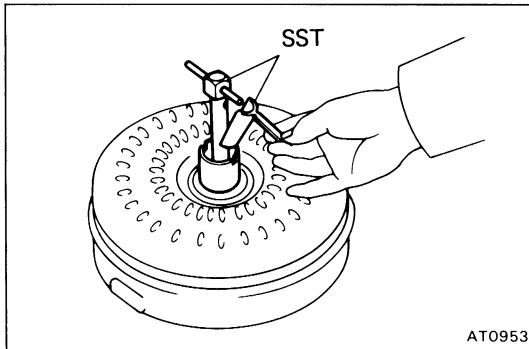
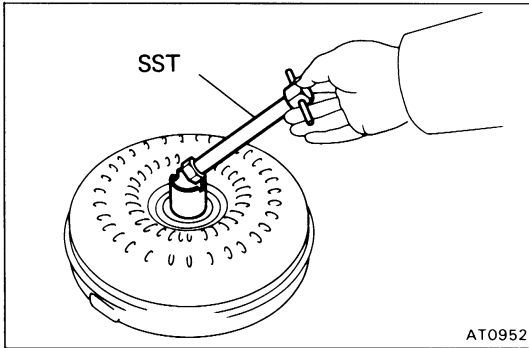

## TORQUE CONVERTER AND DRIVE PLATE

### INSPECTION OF TORQUE CONVERTER AND DRIVE PLATE

#### 1. INSPECT ONE-WAY CLUTCH

(a) Insert SST into the inner race of the one-way clutch.  
SST 09350-30020 (09351-32010)

(b) Insert SST so that it fits in the notch of the converter hub and outer race of the one-way clutch.  
SST 09350-30020 (09351-32020)

(c) With the torque converter standing on its side, the clutch locks when turned counterclockwise, and rotates freely and smoothly clockwise.

If necessary, clean the converter and retest the clutch. Replace the converter if the clutch still fails the test.

#### 2. MEASURE DRIVE PLATE RUNOUT AND INSPECT RING GEAR

Set up a dial indicator and measure the drive plate runout. If runout exceeds 0.20 mm (0.0079 in.) or if the ring gear is damaged, replace the drive plate. If installing a new drive plate, note the orientation of spacers and tighten the bolts.

**Torque: 750 kg-cm (54 ft-lb, 74 N·m)**

#### 3. MEASURE TORQUE CONVERTER SLEEVE RUNOUT

(a) Temporarily mount the torque converter to the drive plate. Set up a dial indicator.

If runout exceeds 0.30 mm (0.0118 in.), try to correct by reorienting the installation of the converter. If excessive runout cannot be corrected, replace the torque converter.

**HINT:** Mark the position of the converter to ensure correct installation.

(b) Remove the torque converter.

# REMOVAL OF COMPONENT PARTS

## COMPONENTS

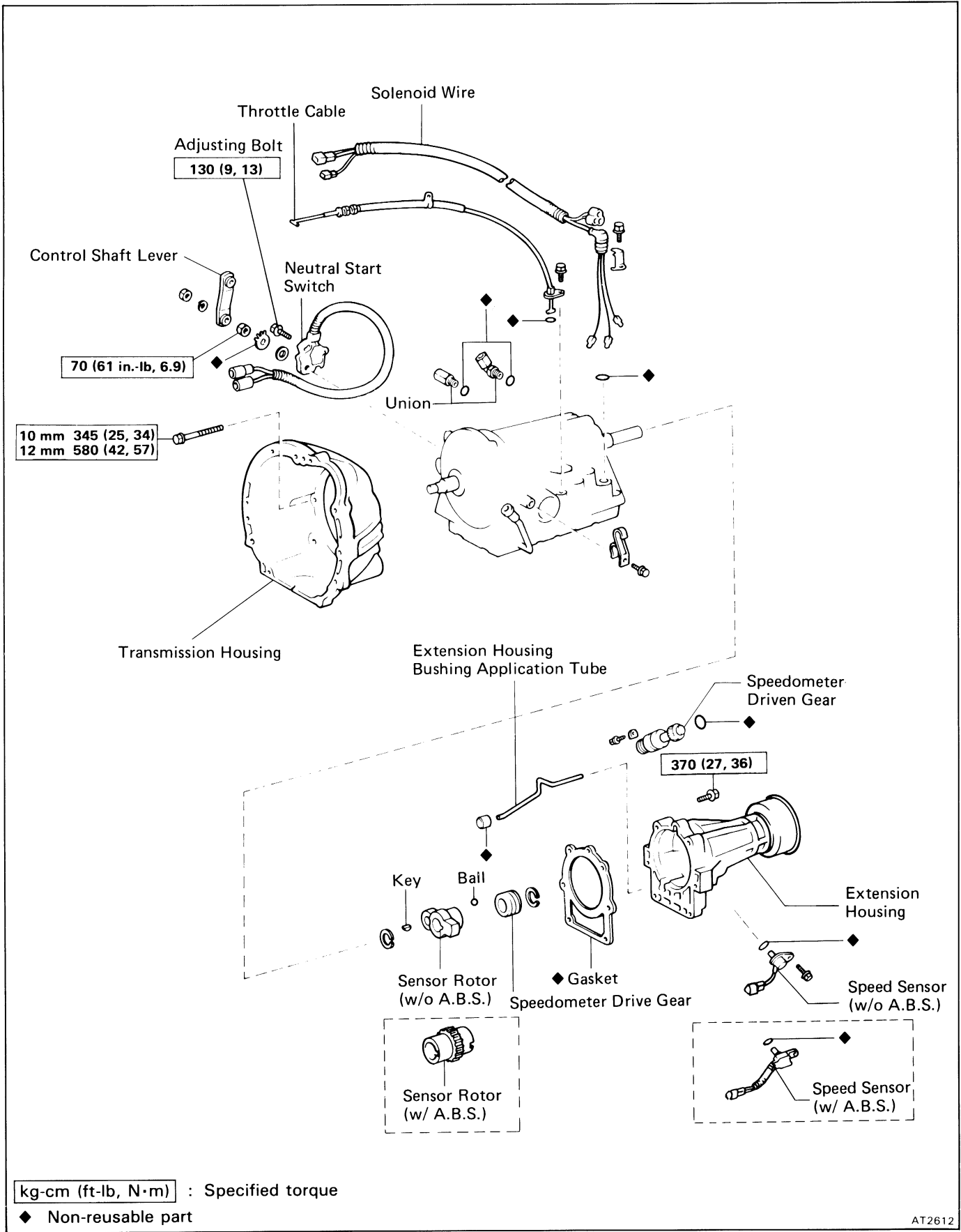

COMPONENTS (Cont'd)

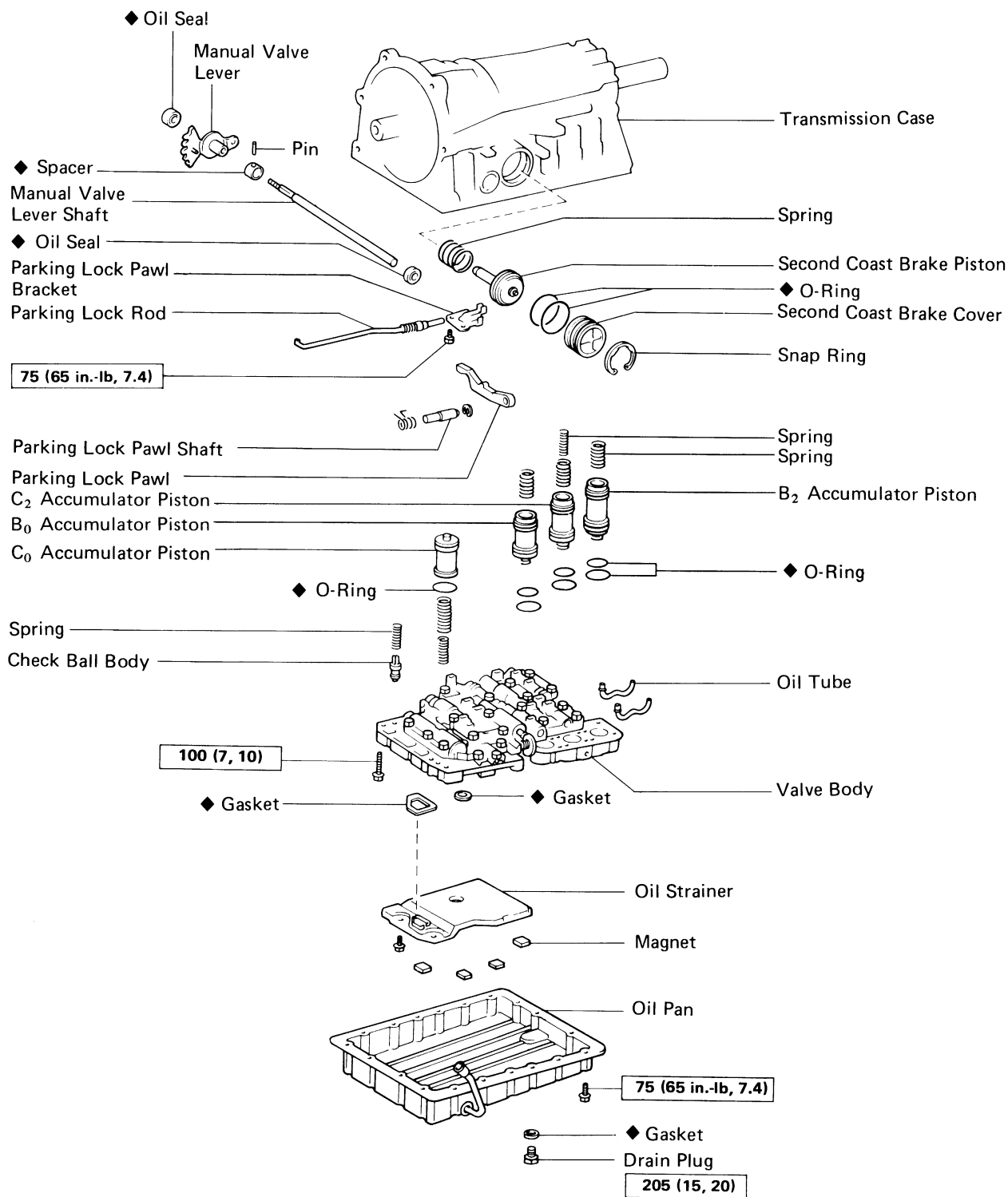

kg-cm (ft-lb, N·m) : Specified torque

◆ Non-reusable part

COMPONENTS (Cont'd)

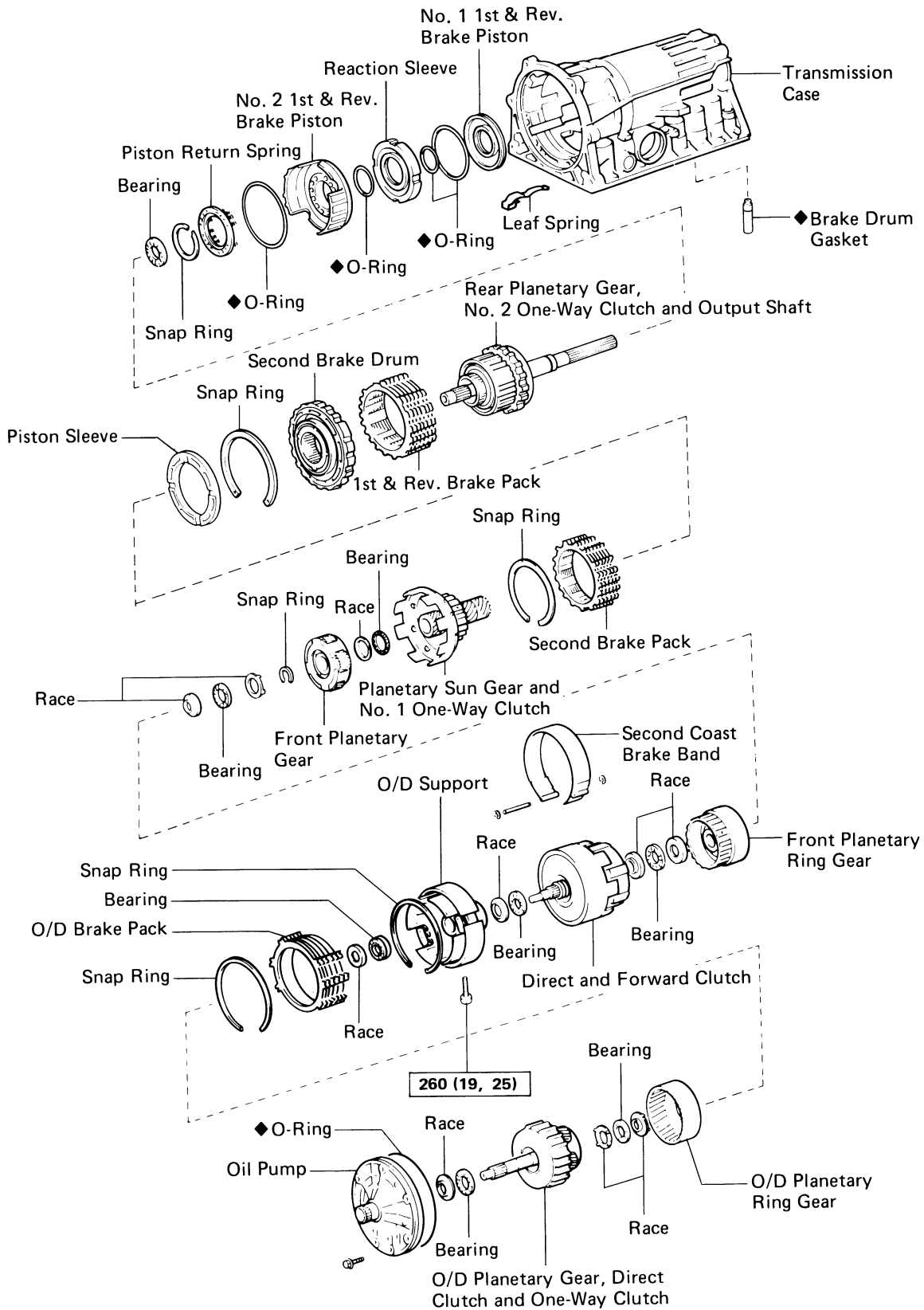

kg-cm (ft-lb, N·m) : Specified torque

◆ Non-reusable part



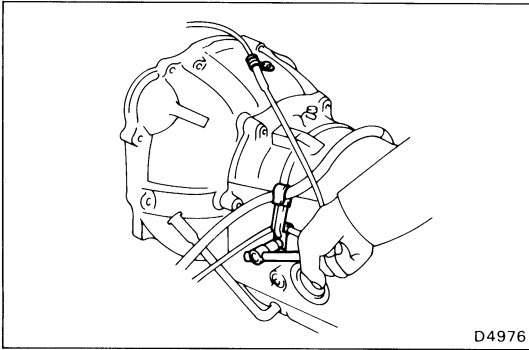

## SEPARATE BASIC SUBASSEMBLY

1. REMOVE WIRE HARNESS CLAMP AND THROTTLE CABLE CLAMP

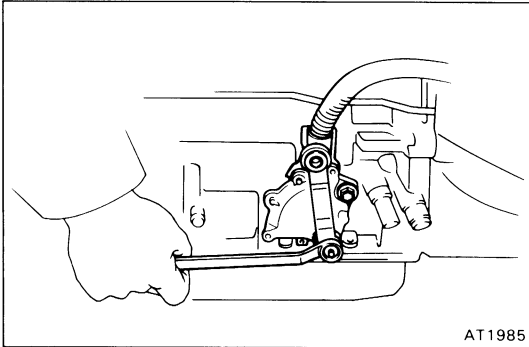

2. REMOVE CONTROL SHAFT LEVER

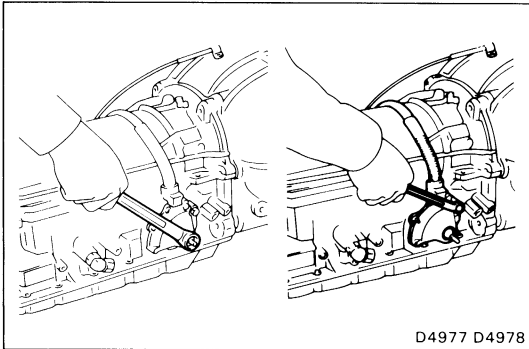

3. REMOVE NEUTRAL START SWITCH

- (a) Unstake the lock washer.
- (b) Remove the nut and bolt, and then remove the neutral start switch.
- (c) Remove the lock washer and grommet.

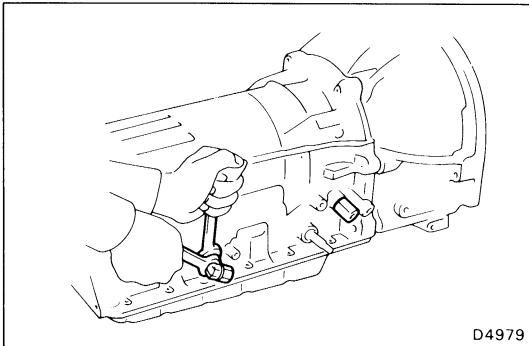

4. REMOVE UNIONS

- (a) Remove the two unions.
- (b) Remove the O-ring from the both unions.

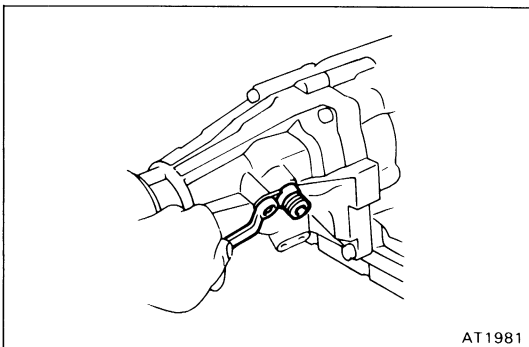

5. REMOVE SPEEDOMETER DRIVEN GEAR

- (a) Remove the speedometer driven gear.
- (b) Remove the O-ring from it.

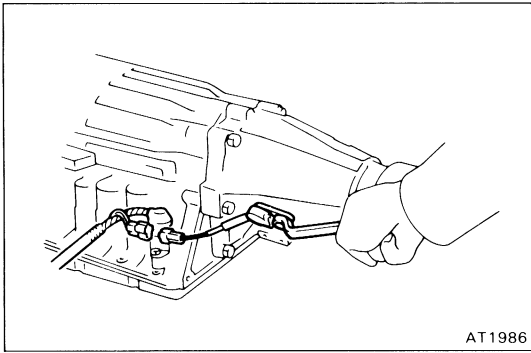
**6. REMOVE SPEED SENSOR**

- (a) Disconnect the connector.
- (b) Remove the speed sensor.
- (c) Remove the O-ring from it.

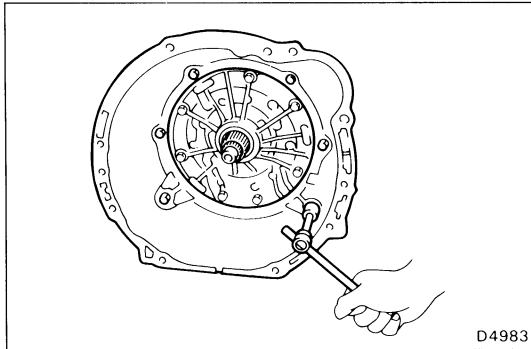
**7. REMOVE TRANSMISSION HOUSING**

- (a) Remove the six bolts.
- (b) Remove the transmission housing.

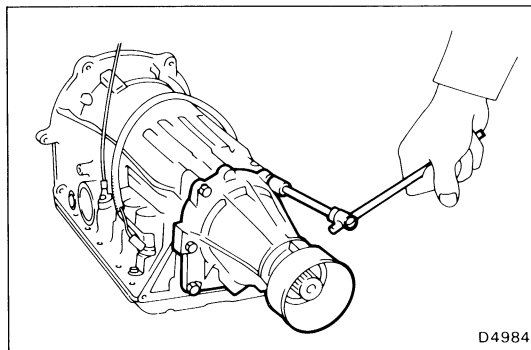
**8. REMOVE EXTENSION HOUSING AND GASKET**

- (a) Remove the six bolts.
- (b) Remove the extension housing and gasket.

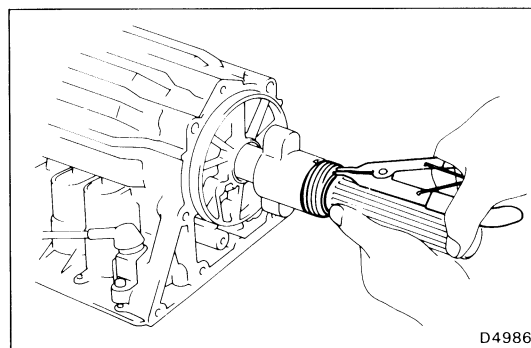
**9. REMOVE SPEEDOMETER DRIVE GEAR AND BALL**

- (a) Using snap ring pliers, remove the snap ring.
- (b) Remove the speedometer drive gear and ball.

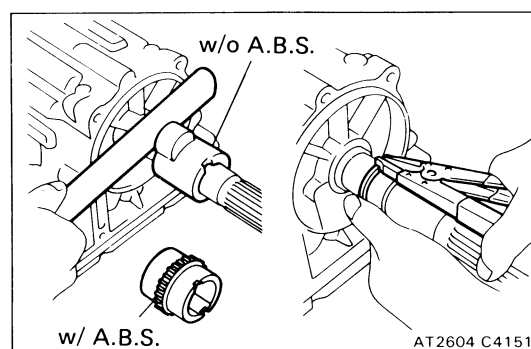
**10. REMOVE SENSOR ROTOR AND KEY**

- (a) Remove the sensor rotor and key.
- (b) Using snap ring pliers, remove the snap ring.

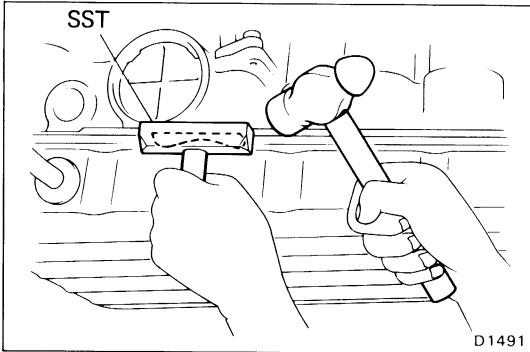

**11. REMOVE OIL PAN**

**NOTICE:** Do not turn the transmission over as this will contaminate the valve body with any foreign matter at the bottom of the pan.

- (a) Remove the nineteen bolts.
- (b) Insert the blade of SST between the transmission case and oil pan, cut off applied sealer.

SST 09032-00100

**NOTICE:** Be careful not to damage the oil pan flange.

- (c) Remove pan by lifting the transmission case.

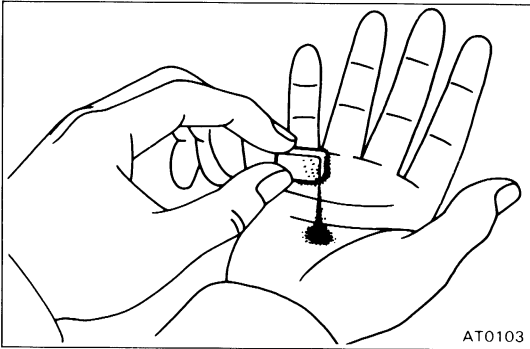

**12. EXAMINE PARTICLES IN PAN**

Remove the magnets and use them to collect steel particles.

Carefully look at the foreign matter and particles in the pan and on the magnets to anticipate the type of wear you will find in the transmission:

- Steel (magnetic) ..... bearing, gear and clutch plate wear
- Brass (non-magnetic) ... bushing wear

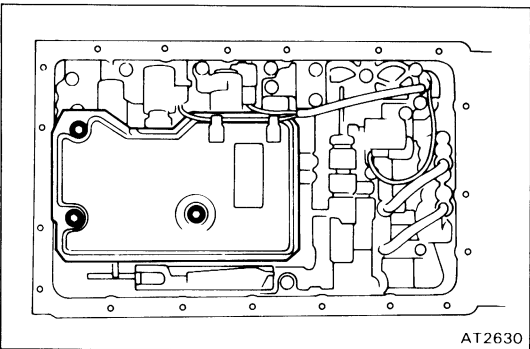

**13. REMOVE OIL STRAINER AND GASKETS**

- (a) Turn over the transmission.
- (b) Remove the three bolts holding the oil strainer to the valve body.
- (c) Remove the oil strainer and two gaskets.

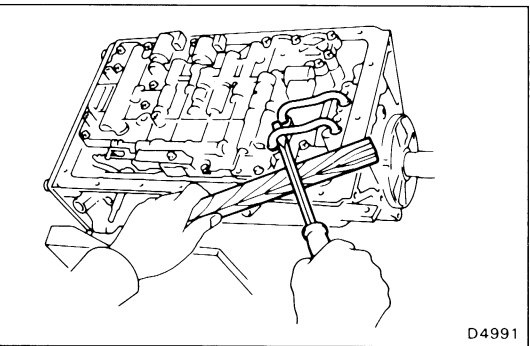

**14. REMOVE OIL TUBES**

Pry up both tube ends with a large screwdriver and remove the two tubes.

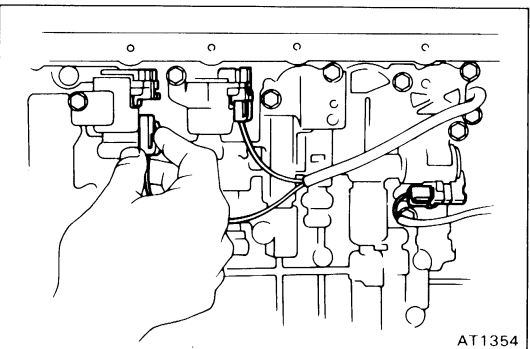

**15. REMOVE SOLENOID WIRING**

- (a) Disconnect the three connectors from No. 1, No. 2 and lock-up solenoids.

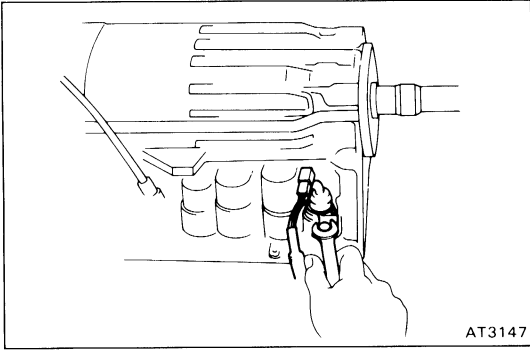

- (b) Turn over transmission, remove the stopper plate from the case.
- (c) Pull the wiring out of the transmission case.
- (d) Remove the O-ring from the grommet.

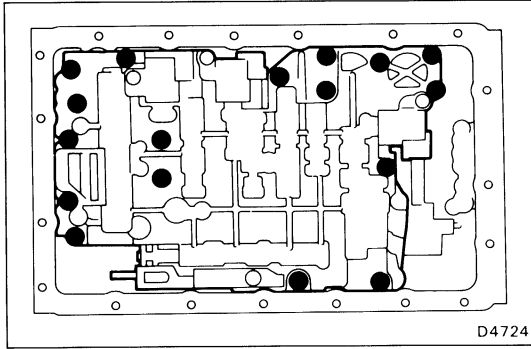

#### 16. REMOVE VALVE BODY

- (a) Remove the seventeen bolts.

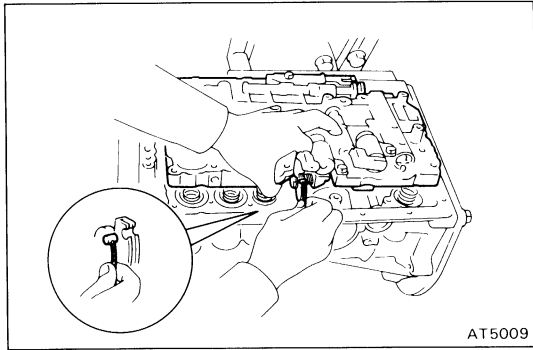

- (b) Disconnect the throttle cable from the cam and remove the valve body.

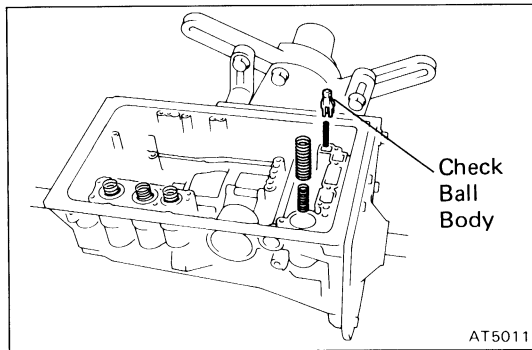

#### 17. REMOVE CHECK BALL BODY, ACCUMULATOR SPRINGS, PINS AND PISTONS

- (a) Remove the check ball body and spring.
- (b) Remove the two springs from the C<sub>0</sub> accumulator piston.

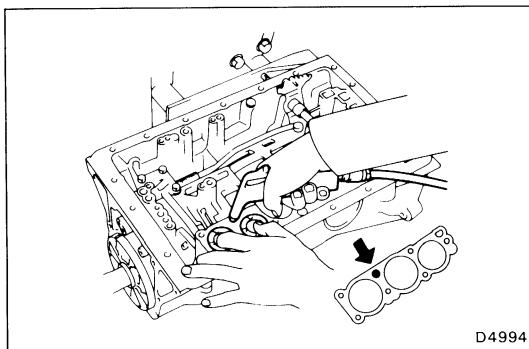

- (c) Applying compressed air to the oil hole, remove the B<sub>2</sub> and C<sub>2</sub> accumulator pistons and three springs.

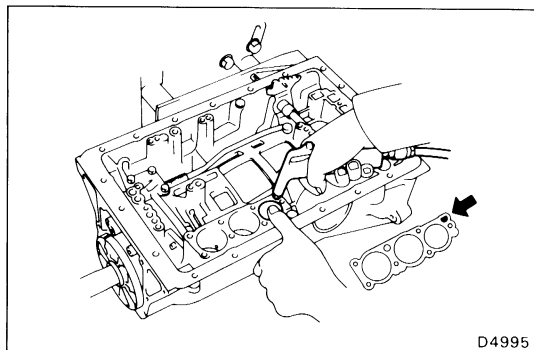

- (d) Applying compressed air to the oil hole, remove the B<sub>0</sub> accumulator piston and spring.

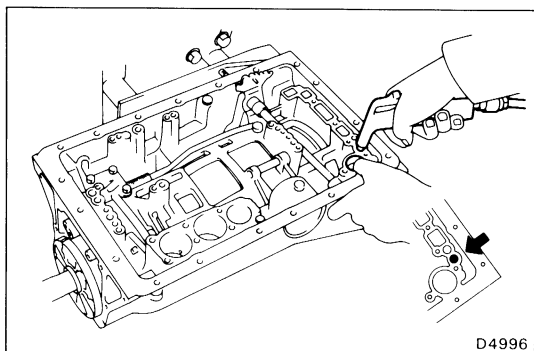

- (e) Applying compressed air to the oil hole, remove the C<sub>0</sub> accumulator piston.
- (f) Remove the O-rings from each piston.

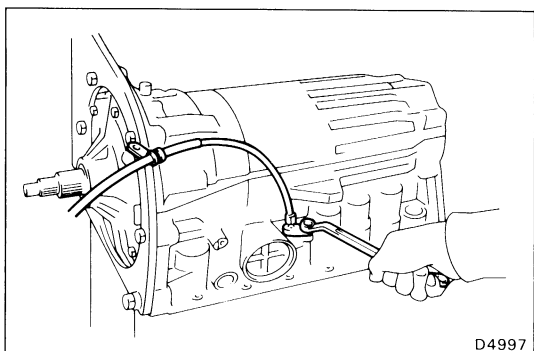

**18. REMOVE THROTTLE CABLE**

- (a) Turn over the transmission.
- (b) Remove the retaining bolt and pull out the throttle cable.
- (c) Remove the O-ring from the cable.

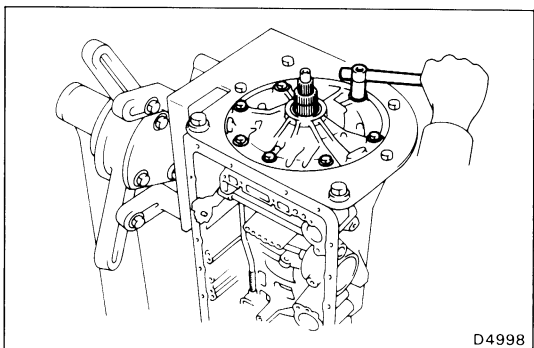

**19. REMOVE OIL PUMP**

- (a) Stand up the transmission.
- (b) Remove the seven bolts holding the oil pump to the transmission case.

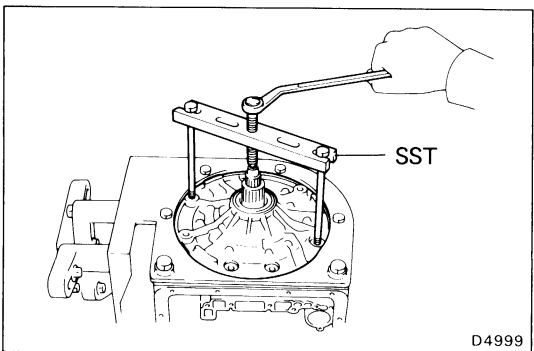

- (c) Using SST, remove the oil pump.  
SST 09350-30020 (09350-07020)
- (d) Remove the O-ring from it.

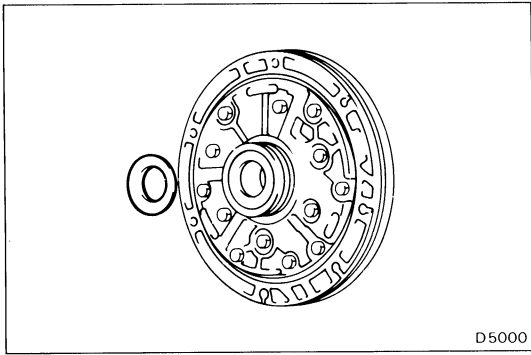

(e) Remove the race from the oil pump.

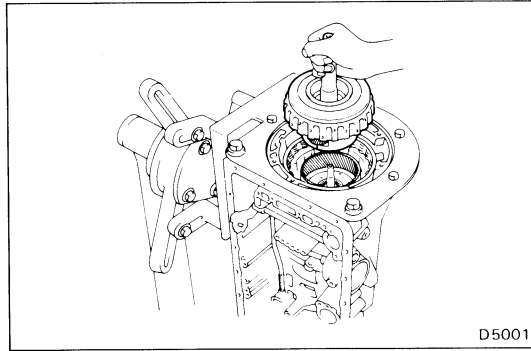

## 20. REMOVE OVERDRIVE PLANETARY GEAR UNIT WITH OVERDRIVE DIRECT CLUTCH AND ONE-WAY CLUTCH

(a) Remove the overdrive planetary gear with the overdrive direct clutch and one-way clutch from the transmission case.

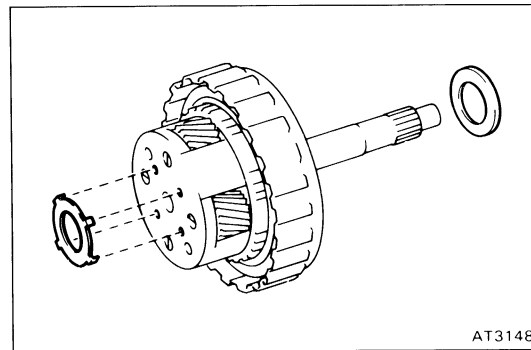

(b) Remove the race and assembled bearing and race.

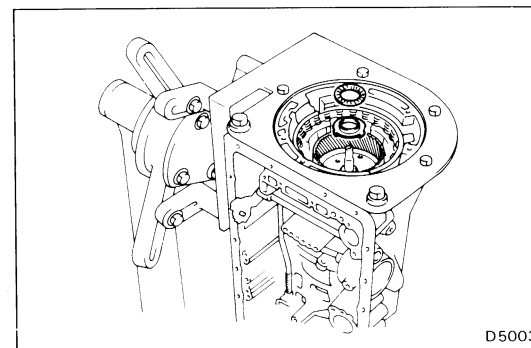

(c) Remove the bearing and race.

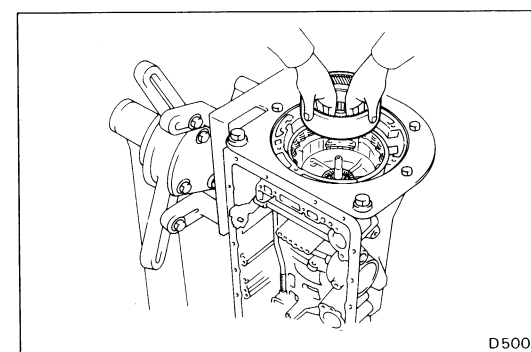

(d) Remove the overdrive planetary ring gear from the transmission case.

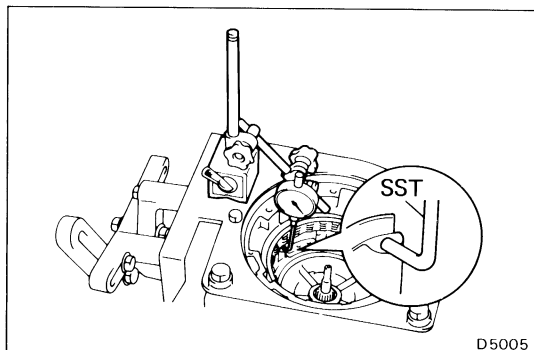

**21. CHECK PISTON STROKE OF OVERDRIVE BRAKE**

- (a) Place SST and a dial indicator onto the overdrive brake piston as shown in the figure.

SST 09350-30020 (09350-06120)

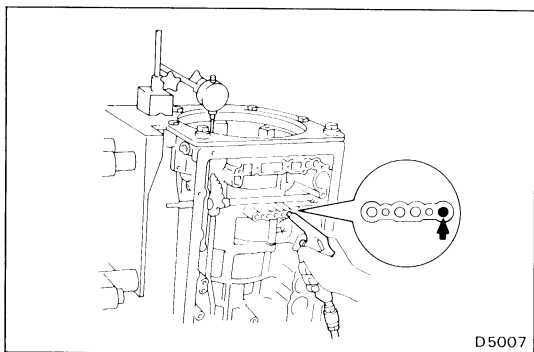

- (b) Measure the stroke applying and releasing the compressed air (4 – 8 kg/cm<sup>2</sup>, 57 – 114 psi or 392 – 785 kPa) as shown in the figure.

**Piston stroke:**

7M-GE 1.40 – 1.70 mm (0.0551 – 0.0669 in.)

7M-GTE 1.75 – 2.05 mm (0.0689 – 0.0807 in.)

If the values are nonstandard, inspect the discs.  
(See page AT-80)

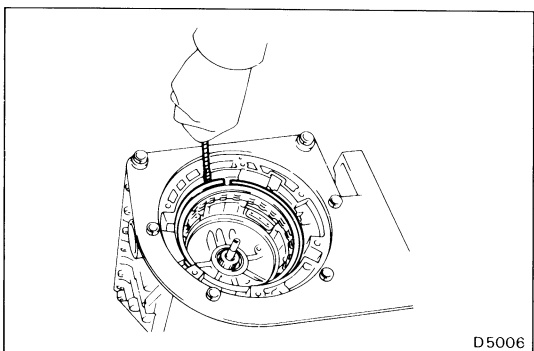

**22. REMOVE FLANGES, PLATES AND DISCS OF OVERDRIVE BRAKE**

- (a) Remove the snap ring.

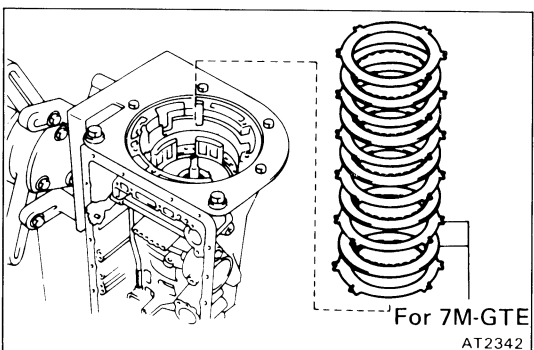

- (b) Remove the flanges, plates and discs as a set.

7M-GE: Two flanges, three plates and four discs

7M-GTE: Two flanges, four plates and five discs

The method of inspection, refer to AT-80.

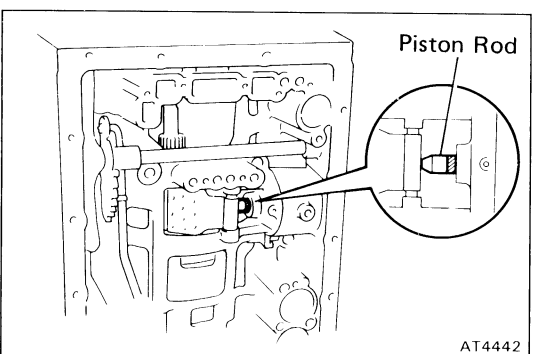

**23. CHECK PISTON ROD STROKE OF SECOND COAST BRAKE**

- (a) Place a mark on the second coast brake piston rod as shown in the figure.

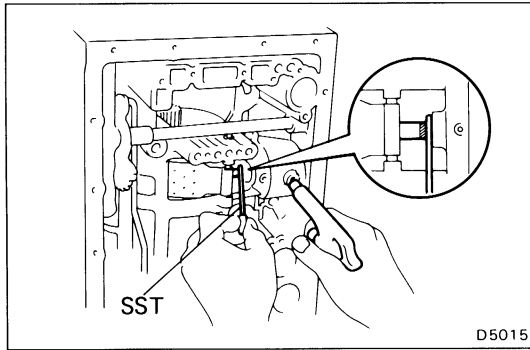

- (b) Using SST, measure the stroke applying the compressed air (4 — 8 kg/cm<sup>2</sup>, 57 — 114 psi or 392 — 785 kPa) as shown in the figure.

SST 09240-00020

**Piston rod stroke: 1.5 — 3.0 mm (0.059 — 0.118 in.)**

If the values are nonstandard, inspect the brake band.  
(See page AT-93)

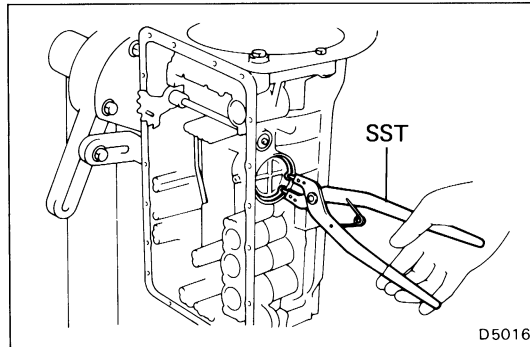

#### 24. REMOVE SECOND COAST BRAKE COVER, PISTON ASSEMBLY AND SPRING

- (a) Using SST, remove the snap ring.

SST 09350-30020 (09350-07060)

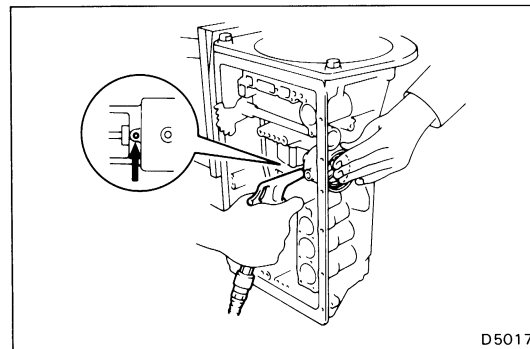

- (b) Applying compressed air to the oil hole, remove the second coast brake cover, piston assembly and spring.

- (c) Remove the two O-rings from the cover.

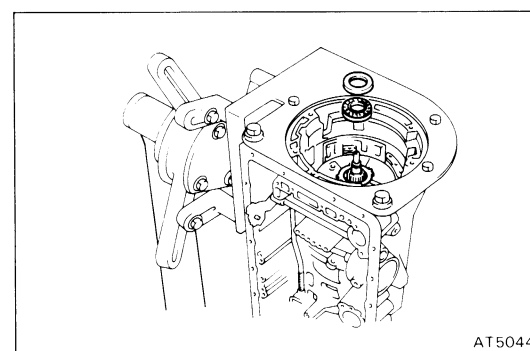

#### 25. REMOVE OVERDRIVE SUPPORT ASSEMBLY

- (a) Remove the bearing and race.

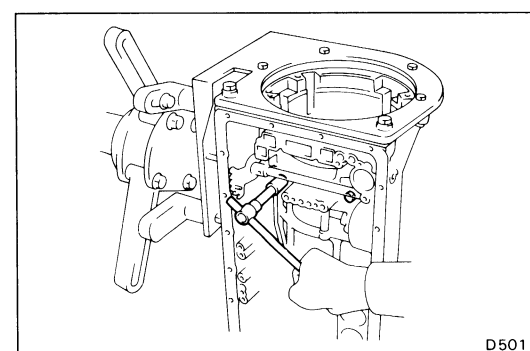

- (b) Remove the two bolts holding the overdrive support assembly to the case.



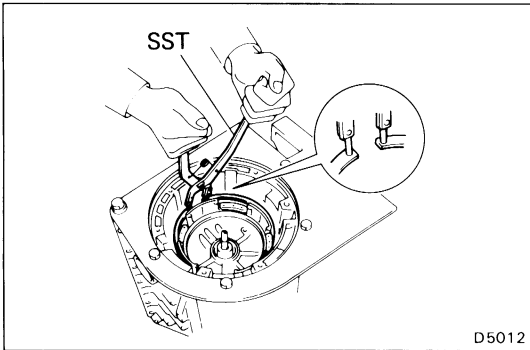

(c) Using SST, remove the snap ring.  
SST 09350-30020 (09350-07060)

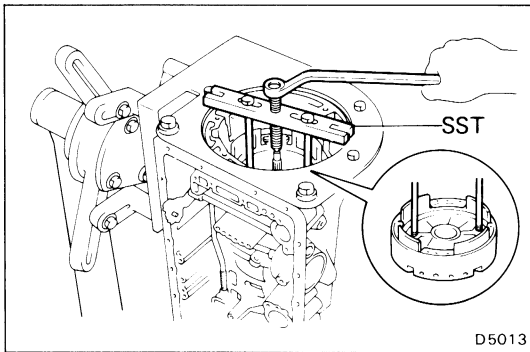

(d) Using SST, remove the overdrive support assembly.  
SST 09350-30020 (09350-07020)

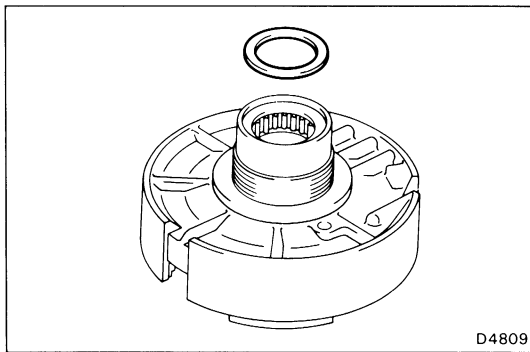

(e) Remove the race.

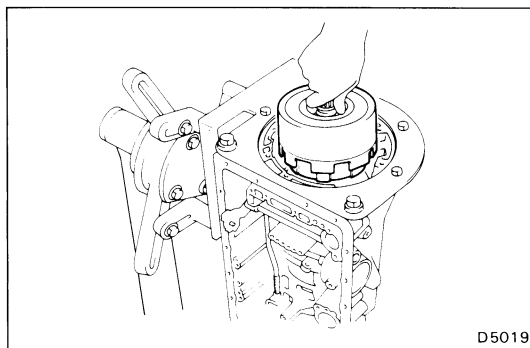

**26. REMOVE DIRECT CLUTCH WITH FORWARD CLUTCH**

(a) Remove the direct clutch with forward clutch from the case.

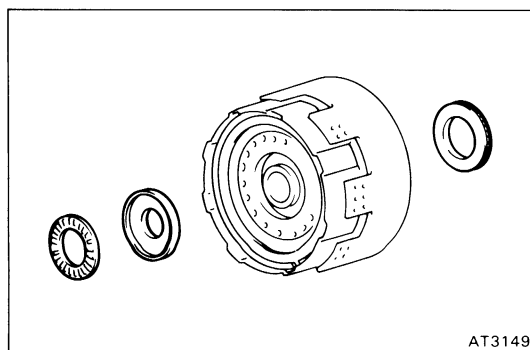

(b) Remove the two bearings and race.

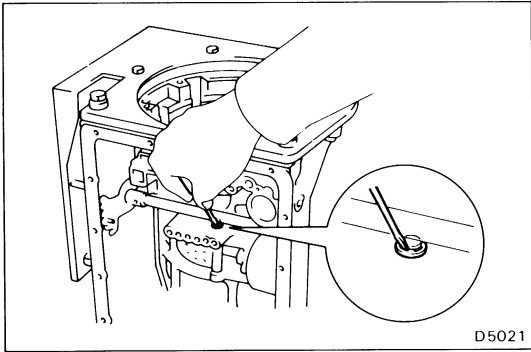
**27. REMOVE SECOND COAST BRAKE BAND**

- (a) Remove the E-ring from the pin.
- (b) Remove the pin from the brake band.

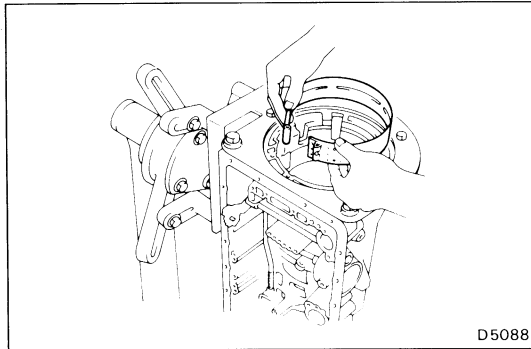

- (c) Remove the second coast brake band from the case.
- For the method of inspection, refer to AT-93.

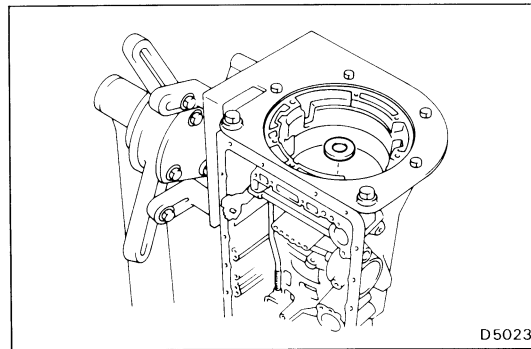
**28. REMOVE FRONT PLANETARY GEAR UNIT**

- (a) Remove the race.

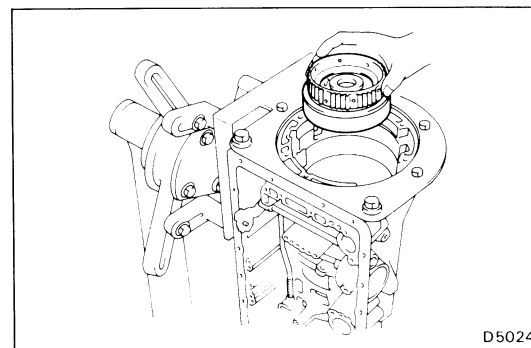

- (b) Remove the front planetary ring gear from the case.

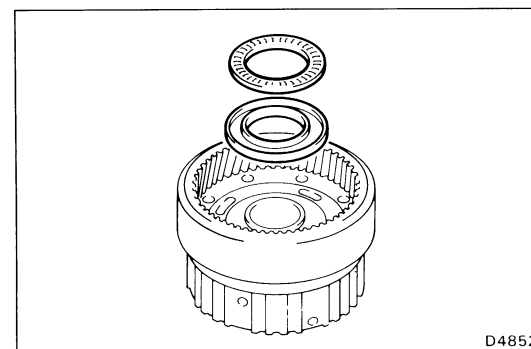

- (c) Remove the bearing and race.

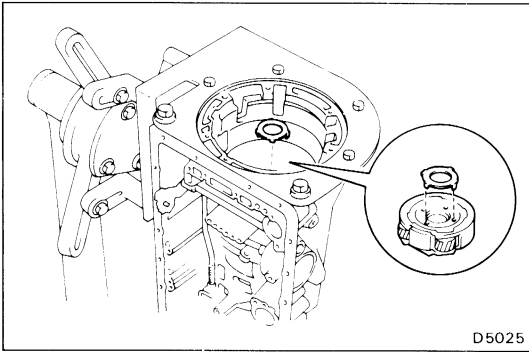

(d) Remove the race.

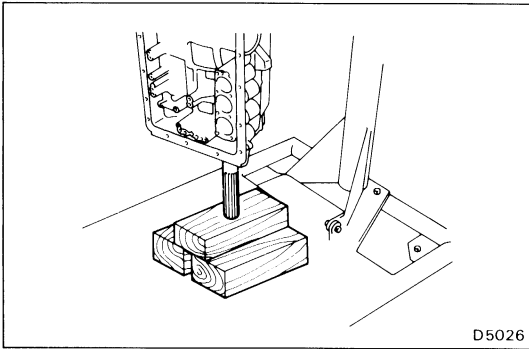

(e) With wooden blocks under the output shaft, stand the transmission on the output shaft.

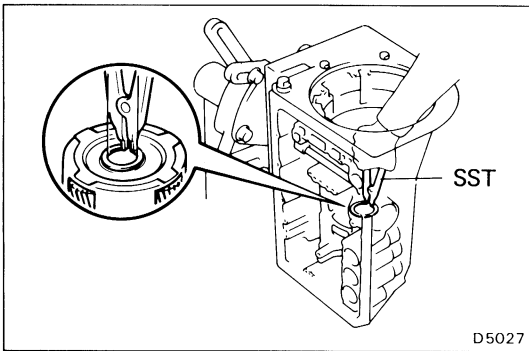

(f) Using SST, remove the snap ring.  
SST 09350-30020 (09350-07070)

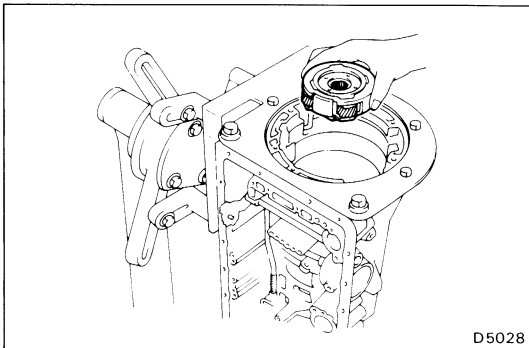

(g) Remove the front planetary gear from the case.

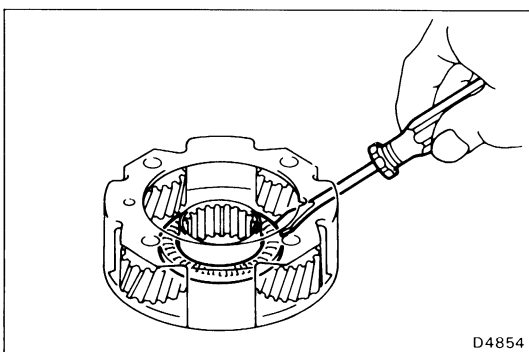

(h) Remove the bearing and race from the front planetary gear.

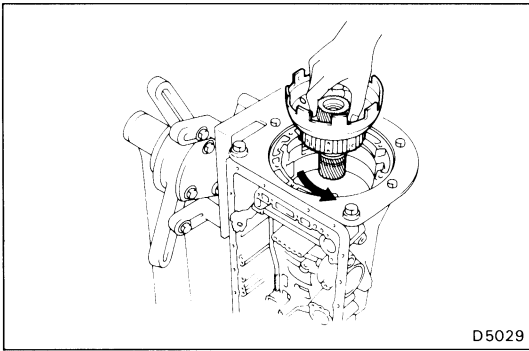

D5029

### 29. REMOVE PLANETARY SUN GEAR WITH NO. 1 ONE-WAY CLUTCH

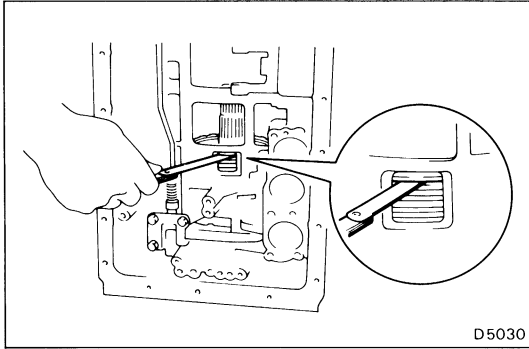

D5030

### 30. CHECK PACK CLEARANCE OF SECOND BRAKE

Using a thickness gauge, measure the clearance between the snap ring and flange as shown in the figure.

**Clearance: 0.62 – 1.98 mm (0.0244 – 0.0780 in.)**

If the values are nonstandard, inspect the discs.  
(See page AT-101)

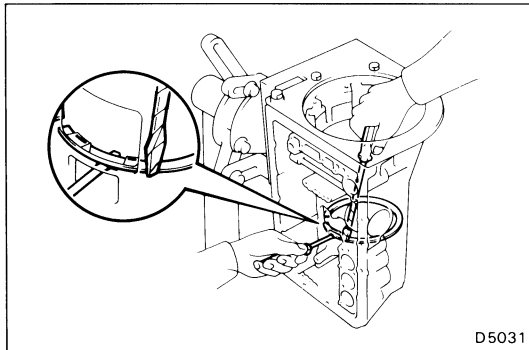

D5031

### 31. REMOVE FLANGE, PLATES AND DISCS OF SECOND BRAKE

(a) Remove the snap ring.

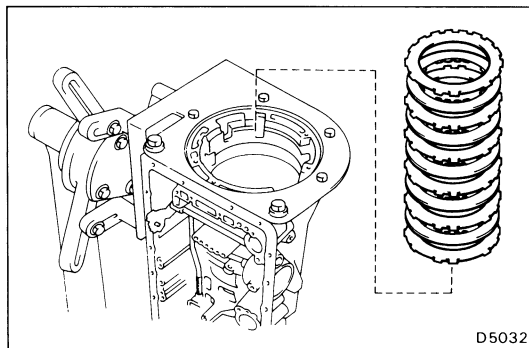

D5032

(b) Remove the flange, five plates and five discs as a set.

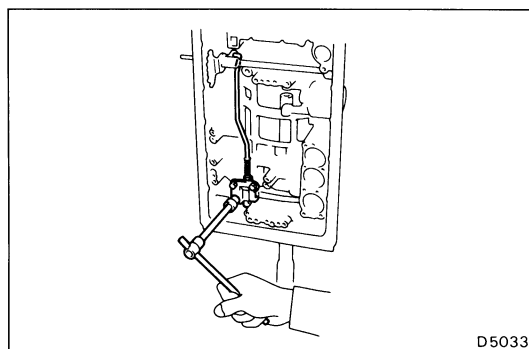

D5033

### 32. REMOVE PARKING LOCK ROD AND PAWL

(a) Remove the parking lock pawl bracket.

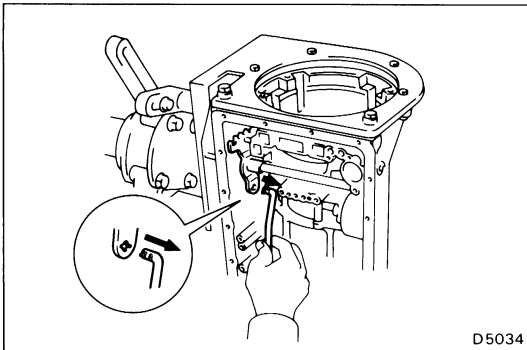

- (b) Disconnect the parking lock rod from the manual valve lever.

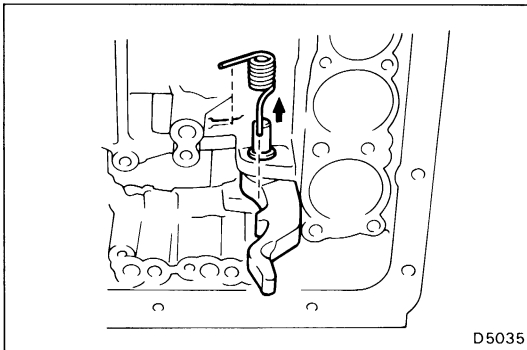

- (c) Remove the spring, parking lock pawl and shaft.  
 (d) Remove the E-ring from the shaft.

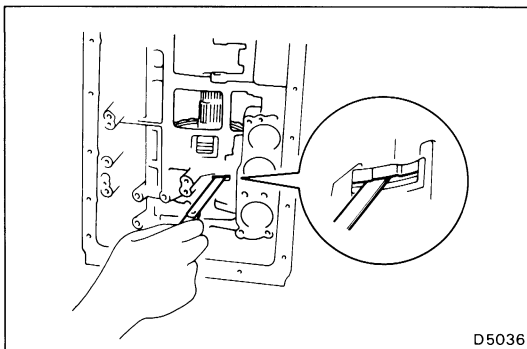

### 33. CHECK PACK CLEARANCE OF FIRST AND REVERSE BRAKE

Using a thickness gauge, measure the clearance between the plate and second brake drum as shown in the figure.

#### Clearance:

7M-GE 0.60 — 1.12 mm (0.0236 — 0.0441 in.)

7M-GTE 0.70 — 1.22 mm (0.0276 — 0.0480 in.)

If the values are nonstandard, inspect the discs.  
 (See page AT-103)

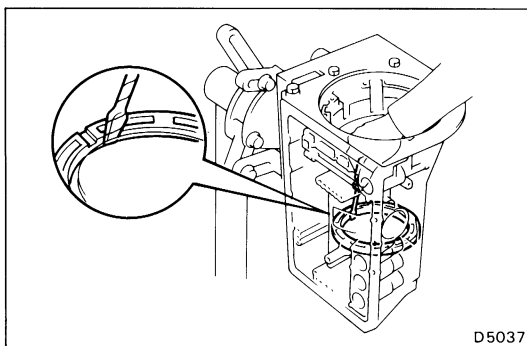

### 34. REMOVE SECOND BRAKE PISTON SLEEVE

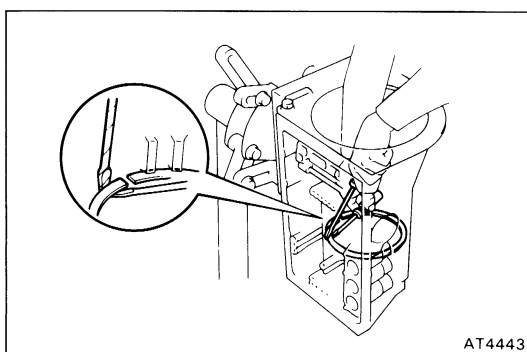

### 35. REMOVE REAR PLANETARY GEAR UNIT WITH SECOND BRAKE DRUM, FIRST AND REVERSE BRAKE PACK AND OUTPUT SHAFT

- (a) Using two screwdrivers, remove the snap ring.

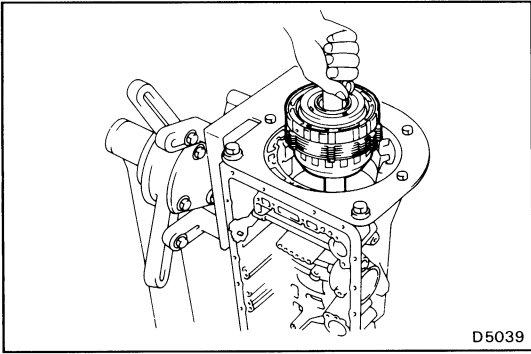

- (b) Remove the rear planetary gear, second brake drum, first and reverse brake pack and output shaft as an assembly.

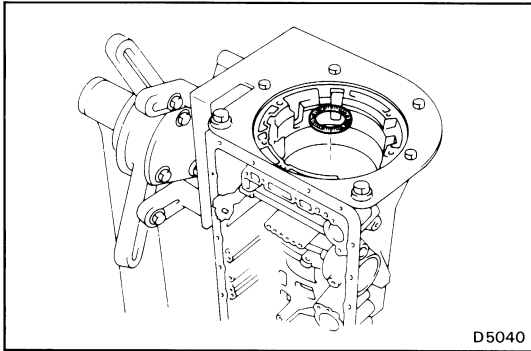

- (c) Remove the assembled thrust bearing and race from the case.

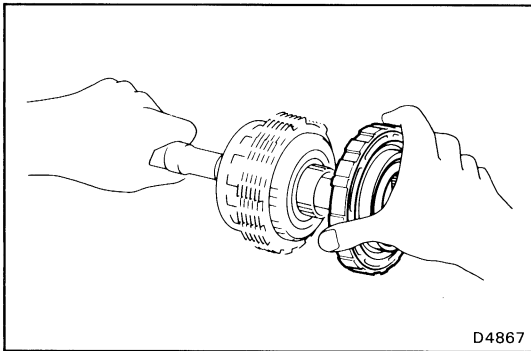

- (d) Remove the second brake drum assembly.

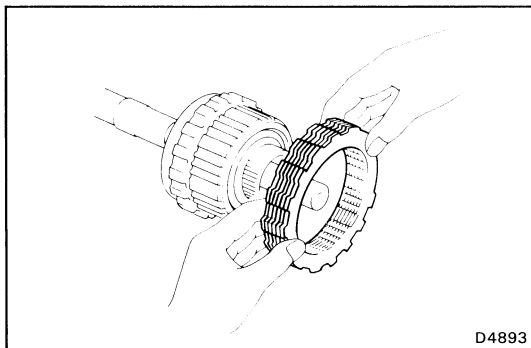

- (e) Remove the flange, plates and discs of the first and reverse brake.

7M-GE: One flange, six plates and six discs  
 7M-GTE: One flange, seven plates and seven discs

For the method of inspection, refer to AT-103.

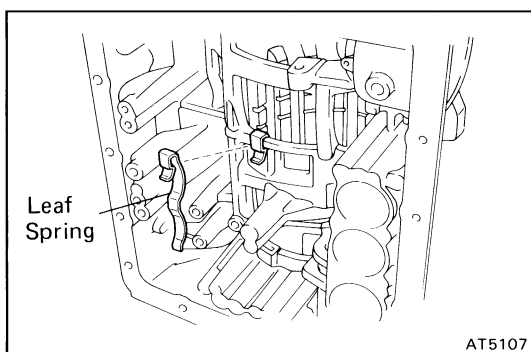

### 36. REMOVE LEAF SPRING

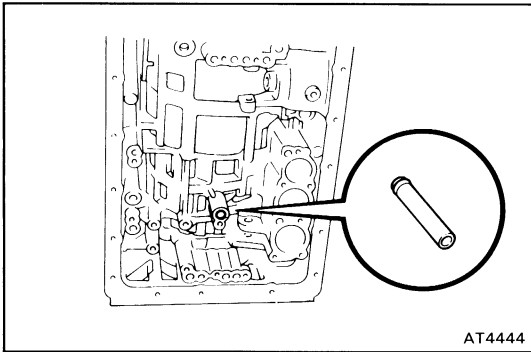

**37. REMOVE BRAKE DRUM GASKET**

Using a screwdriver, remove the gasket.

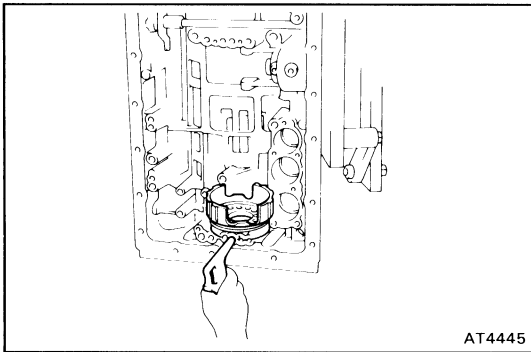

**38. CHECK FIRST AND REVERSE BRAKE PISTONS MOVING**

Make sure the first and reverse brake pistons move smoothly when applying and releasing the compressed air into the transmission case.

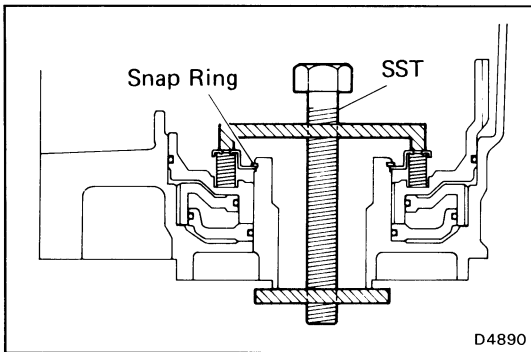

**39. REMOVE COMPONENTS OF FIRST AND REVERSE BRAKE PISTON**

(a) Set SST on the spring retainer, and compress the return spring.

SST 09350-30020 (09350-07050)

(b) Remove the snap ring with snap ring pliers.

(c) Remove the piston return spring.

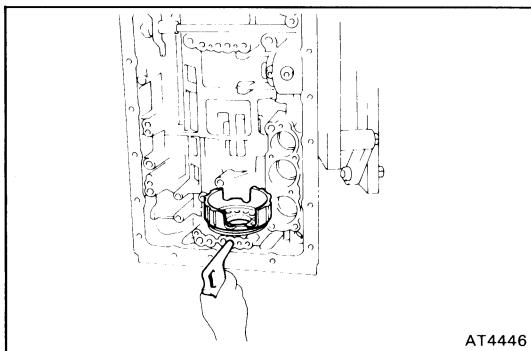

(d) Hold No. 2 first and reverse brake piston with hand, apply compressed air to transmission case to remove No. 2 first and reverse brake piston.

(e) Remove No. 2 first and reverse brake piston.

If the piston does not pop out with compressed air, lift the piston out with needle-nose pliers.

(f) Remove the O-ring from No. 2 piston.

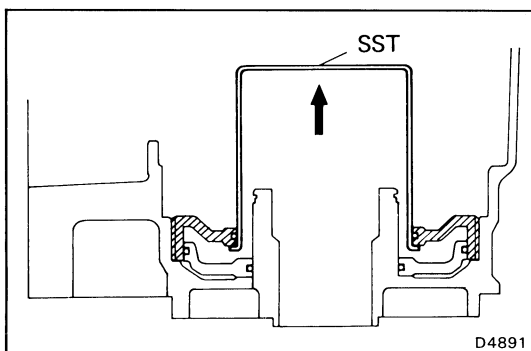

(g) Insert SST behind the reaction sleeve and gradually lift it out of the transmission case.

SST 09350-30020 (09350-07080)

(h) Remove the O-ring from the reaction sleeve.

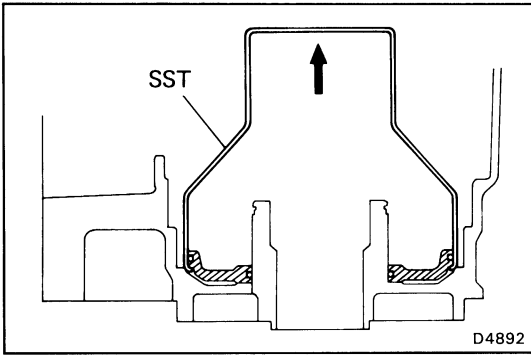

- (i) Insert SST behind No. 1 brake piston and gradually lift it out of the transmission case.

SST 09350-30020 (09350-07090)

- (j) Remove the two O-rings from No. 1 piston.

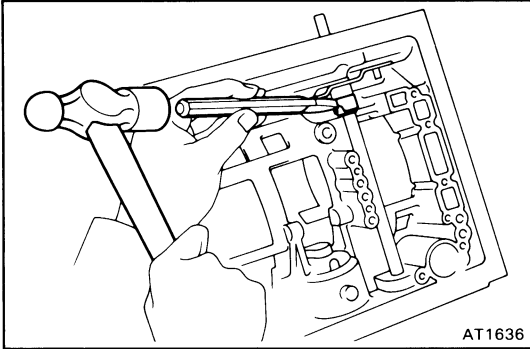

#### 40. REMOVE MANUAL VALVE LEVER, SHAFT AND OIL SEALS

- (a) Using a chisel, cut off the spacer and remove it from the shaft.

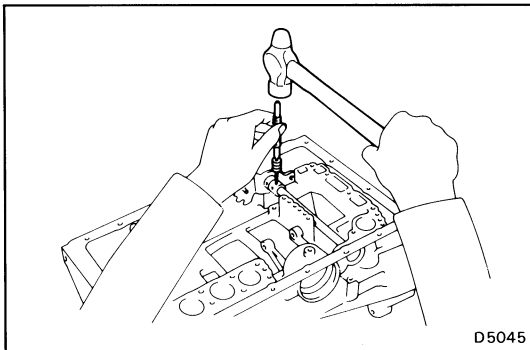

- (b) Using a pin punch, drive out the pin.
- (c) Pull the manual valve lever shaft out through the case and remove the lever.

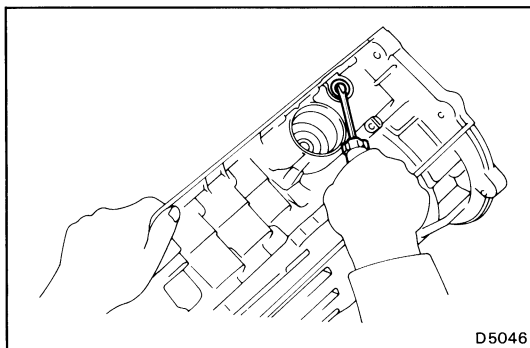

- (d) Using a screwdriver, remove the two oil seals.



# COMPONENT PARTS

## General Notes

The instructions here are organized so that you work on only one component group at a time. This will help avoid confusion from similar-looking parts of different subassemblies being on your workbench at the same time.

The component groups are inspected and repaired from the converter housing side.

As much as possible, complete the inspection, repair and assembly before proceeding to the next component group. If a component group can not be assembled because parts are being ordered, be sure to keep all parts of that group in a separate container while proceeding with disassembly, inspection, repair and assembly of other component groups.

Recommended ATF: DEXRON® II

### GENERAL CLEANING NOTES:

1. All disassembled parts should be washed clean, with any fluid passages and holes blown through with compressed air.
2. When using compressed air to dry parts, always aim away from yourself to prevent accidentally spraying automatic transmission fluid or kerosene on your face.
3. The recommended automatic transmission fluid or kerosene should be used for cleaning.

### PARTS ARRANGEMENT:

1. After cleaning, the parts should be arranged in proper order to allow efficient inspection, repairs, and reassembly.
2. When disassembling a valve body, be sure to keep each valve together with the corresponding spring.
3. New brakes and clutches that are to be used for replacement must be soaked in transmission fluid for at least two hours before assembly.

### GENERAL ASSEMBLY:

1. All oil seal rings, clutch discs, clutch plates, rotating parts, and sliding surfaces should be coated with transmission fluid prior to reassembly.
2. All gaskets and rubber O-rings should be replaced.
3. Make sure that the ends of a snap ring are not aligned with one of the cutouts and are installed in the groove correctly.
4. If a worn bushing is to be replaced, the subassembly containing that bushing must also be replaced.
5. Check thrust bearings and races for wear or damage. Replace if necessary.
6. Use petroleum jelly to keep parts in place.

# Oil Pump COMPONENTS

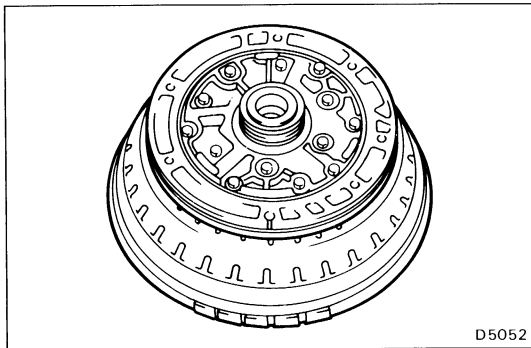
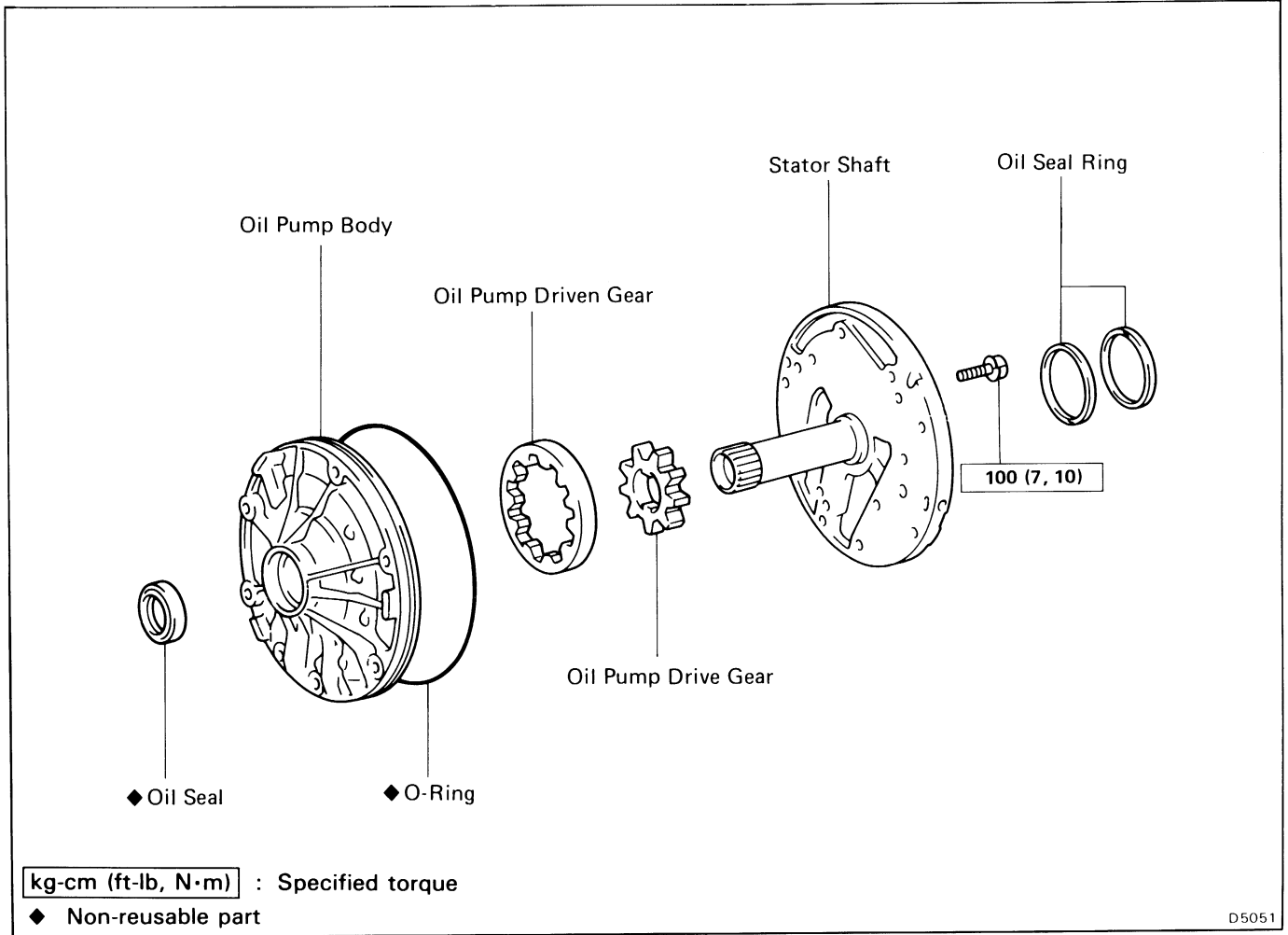

## DISASSEMBLY OF OIL PUMP

1. USE TORQUE CONVERTER AS WORK STAND

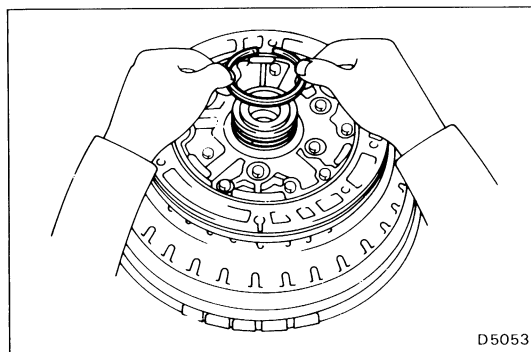

2. REMOVE OIL SEAL RINGS  
Remove the two oil seal rings.

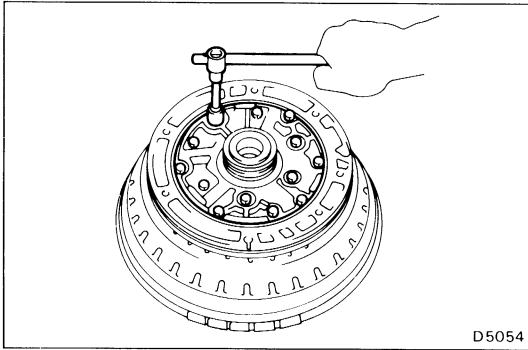

D5054

### 3. REMOVE STATOR SHAFT

Remove the thirteen bolts, and then remove the stator shaft from the oil pump body.

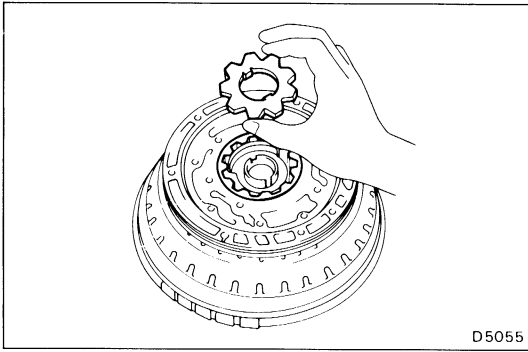

D5055

### 4. REMOVE OIL PUMP DRIVE GEAR AND DRIVEN GEAR

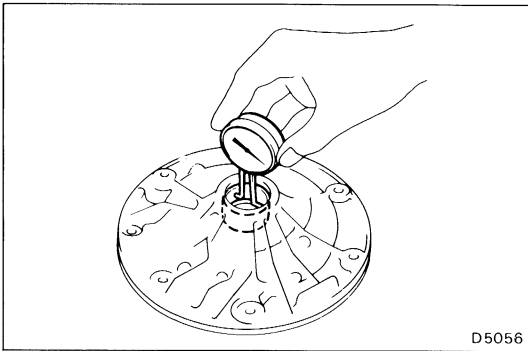

D5056

## INSPECTION OF OIL PUMP

### 1. CHECK OIL PUMP BODY BUSHING

Using a dial indicator, measure the inside diameter of the oil pump body bushing.

**Maximum inside diameter: 38.19 mm (1.5035 in.)**

If the inside diameter is greater than the maximum, replace the oil pump body.

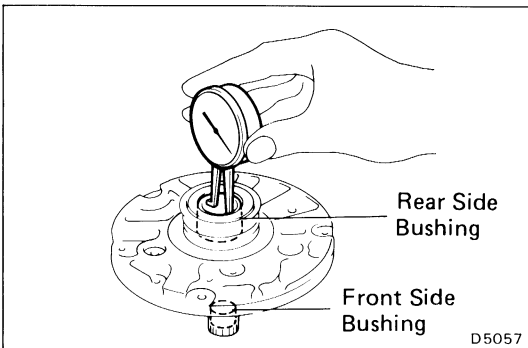

D5057

### 2. CHECK STATOR SHAFT BUSHING

Using a dial indicator, measure the inside diameter of the stator shaft bushing.

**Maximum inside diameter:**

**Front side 21.58 mm (0.8496 in.)**

**Rear side 27.08 mm (1.0661 in.)**

If the inside diameter is greater than the maximum, replace the stator shaft.

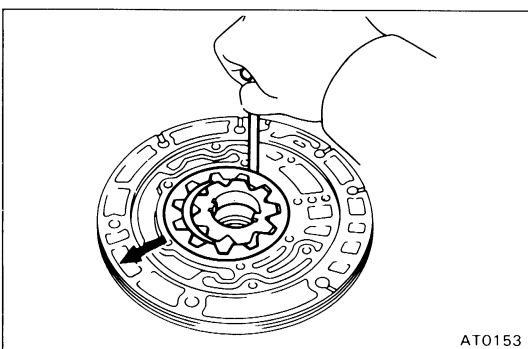

AT0153

### 3. CHECK BODY CLEARANCE OF DRIVEN GEAR

Push the driven gear to one side of the body.

Using a feeler gauge, measure the clearance.

**Standard body clearance: 0.07 – 0.15 mm  
(0.0028 – 0.0059 in.)**

**Maximum body clearance: 0.3 mm (0.012 in.)**

If the body clearance is greater than the maximum, replace the drive gear, driven gear or pump body.

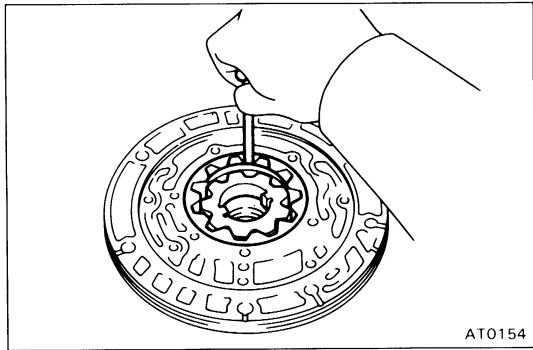

#### 4. CHECK TIP CLEARANCE OF DRIVEN GEAR

Measure between the driven gear teeth and the crescent-shaped part of the pump body.

**Standard tip clearance: 0.11 – 0.14 mm  
(0.0043 – 0.0055 in.)**

**Maximum tip clearance: 0.3 mm (0.012 in.)**

If the tip clearance is greater than the maximum, replace the drive gear, driven gear or pump body.

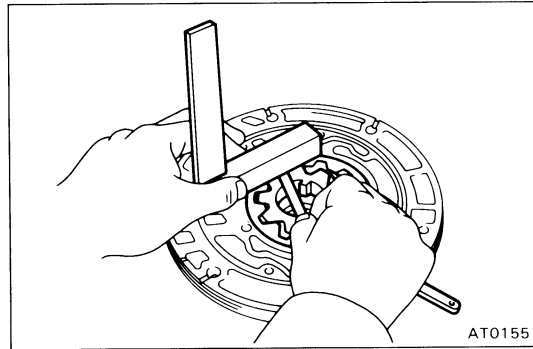

#### 5. CHECK SIDE CLEARANCE OF BOTH GEARS

Using a steel straight edge and a feeler gauge, measure the side clearance of both gears.

**Standard side clearance: 0.02 – 0.05 mm  
(0.0008 – 0.0020 in.)**

**Maximum side clearance: 0.1 mm (0.004 in.)**

If the side clearance is greater than the maximum, replace the drive gear, driven gear or pump body.

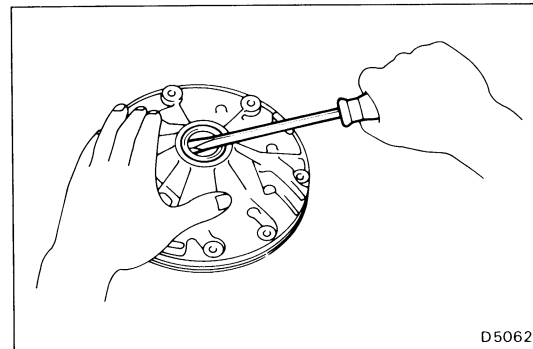

#### 6. IF NECESSARY, REPLACE OIL SEAL

(a) Pry off the oil seal with a screwdriver.

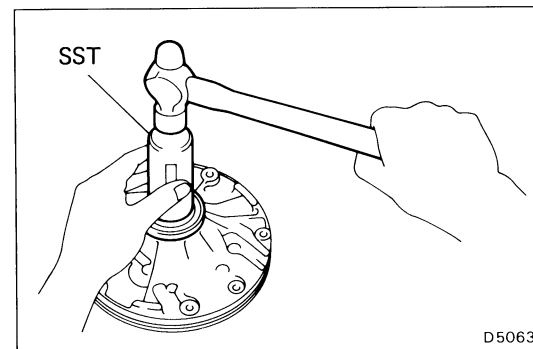

(b) Using SST, install a new oil seal.

The oil seal end should be flushed with the outer edge of the pump body.

SST 09350-30020 (09351-32140)

(c) Coat the oil seal lip with MP grease.

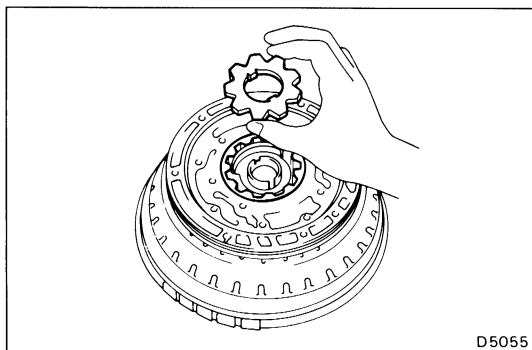

D5055

## ASSEMBLY OF OIL PUMP

### 1. INSTALL DRIVEN GEAR AND DRIVE GEAR TO OIL PUMP BODY

- (a) Place the oil pump body on the torque converter.
- (b) Coat the driven gear and drive gear with ATF.
- (c) Install the driven gear and drive gear.

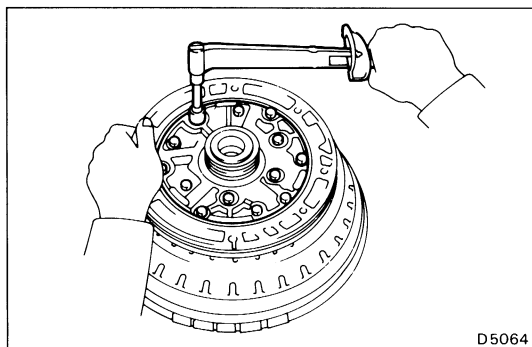

D5064

### 2. INSTALL STATOR SHAFT TO OIL PUMP BODY

- (a) Align the stator shaft with each bolt hole.
- (b) Tighten the thirteen bolts.

**Torque: 100 kg-cm (7 ft-lb, 10 N·m)**

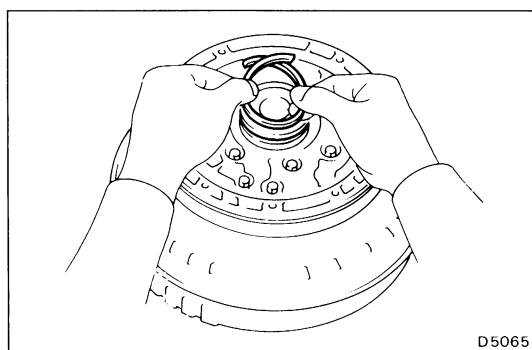

D5065

### 3. INSTALL OIL SEAL RINGS

- (a) Coat the two oil seal rings with ATF.
- (b) Contract the oil seal rings as shown, and install them onto the stator shaft.

**NOTICE: Do not spread the ring ends too much.**

**HINT: After installing the oil seal rings, check that they rotate smoothly.**

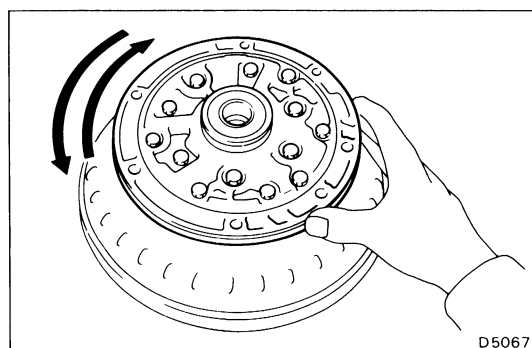

D5067

### 4. CHECK OIL PUMP DRIVE GEAR ROTATION

Make sure the drive gear rotates smoothly.

# Overdrive Planetary Gear, Overdrive Direct Clutch and Overdrive One-Way Clutch

## COMPONENTS

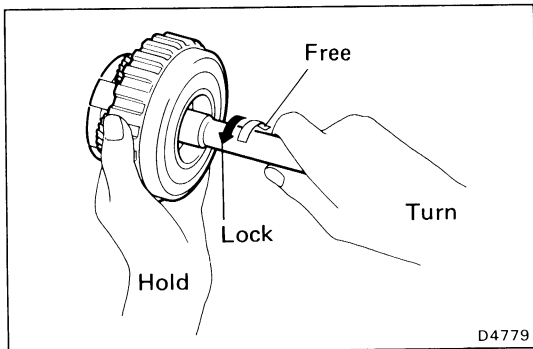
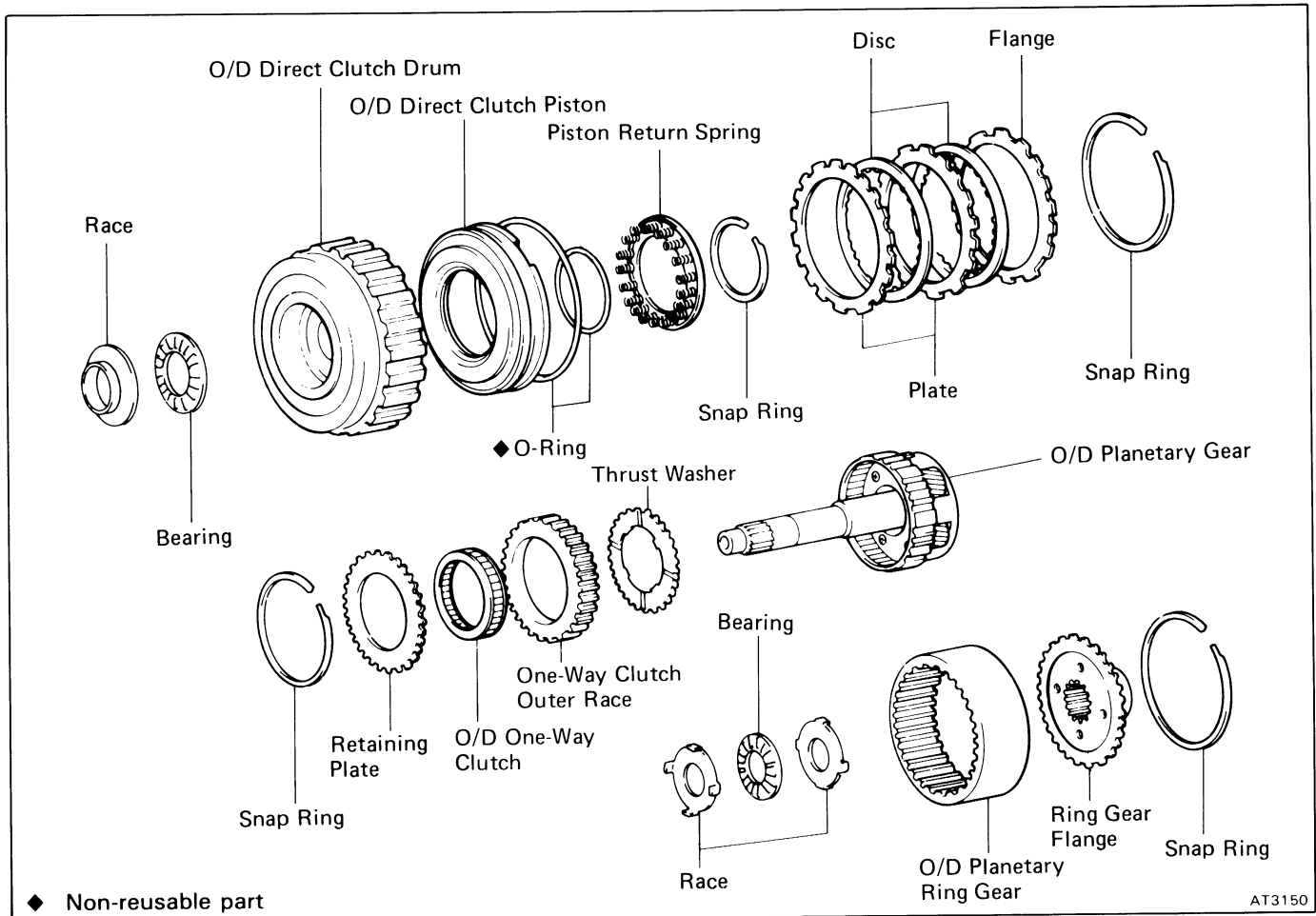

### DISASSEMBLY OF OVERDRIVE PLANETARY GEAR, OVERDRIVE DIRECT CLUTCH AND OVERDRIVE ONE-WAY CLUTCH

#### 1. CHECK OPERATION OF ONE-WAY CLUTCH

Hold the O/D direct clutch drum and turn the input shaft. The input shaft turns freely clockwise and locks counter-clockwise.

#### 2. REMOVE OVERDRIVE DIRECT CLUTCH ASSEMBLY FROM OVERDRIVE PLANETARY GEAR

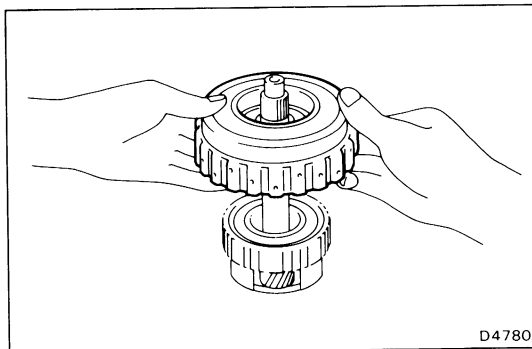

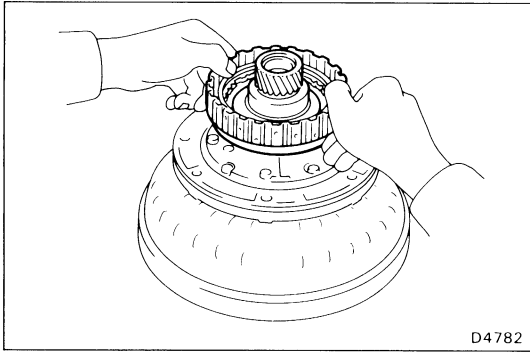

D4782

**3. CHECK PISTON STROKE OF OVERDRIVE DIRECT CLUTCH**

- (a) Place the oil pump onto the torque converter, and then place the O/D direct clutch assembly onto the oil pump.

- (b) Using SST and a dial indicator, measure the O/D direct clutch piston stroke applying and releasing the compressed air (4 – 8 kg/cm<sup>2</sup>, 57 – 114 psi or 392 – 785 kPa) as shown.

SST 09350-30020 (09350-06120)

**Piston stroke: 1.85 – 2.15 mm (0.0728 – 0.0846 in.)**

If the values are nonstandard, inspect the discs.

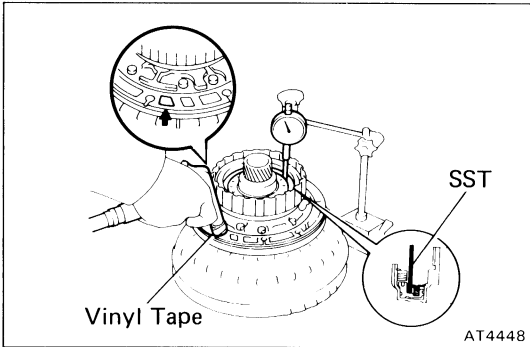

AT4448

**4. REMOVE FLANGE, PLATES AND DISCS**

- (a) Remove the snap ring from the O/D direct clutch drum.
- (b) Remove the flange, two plates and two discs.

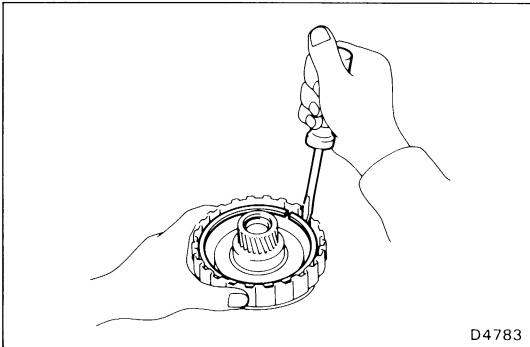

D4783

**5. REMOVE PISTON RETURN SPRING**

- (a) Place SST on the spring retainer and compress the return spring with a shop press.

SST 09350-30020 (09350-07040)

- (b) Using snap ring pliers, remove the snap ring.
- (c) Remove the piston return spring.

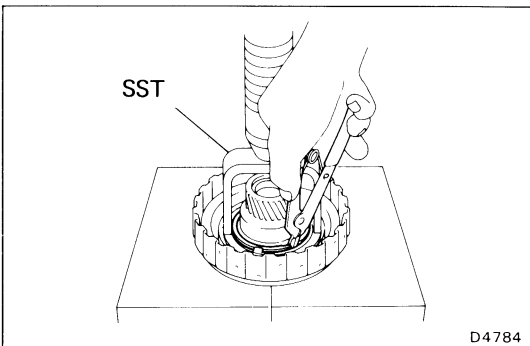

D4784

**6. REMOVE OVERDRIVE DIRECT CLUTCH PISTON**

- (a) Place the oil pump onto the torque converter and then place the O/D direct clutch onto the oil pump.
- (b) Hold the O/D direct clutch piston with hand, apply compressed air to the oil pump to remove the O/D direct clutch piston.
- (c) Remove the O/D direct clutch piston.
- (d) Remove the two O-rings from the piston.

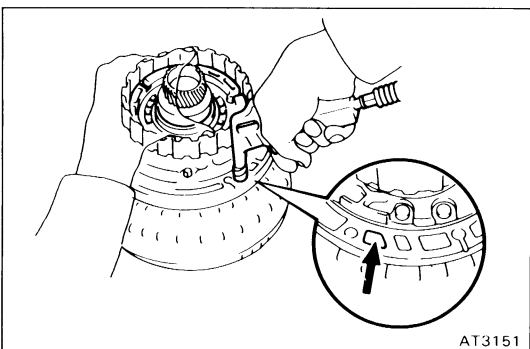

AT3151

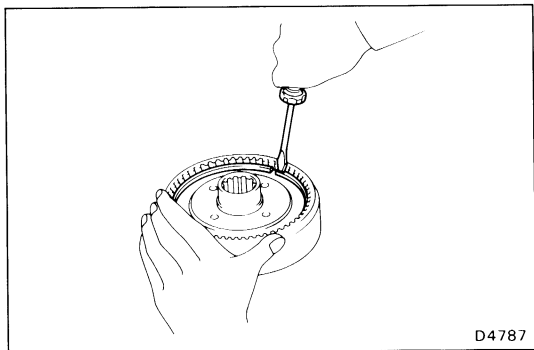
**7. REMOVE RING GEAR FLANGE**

(a) Remove the snap ring.

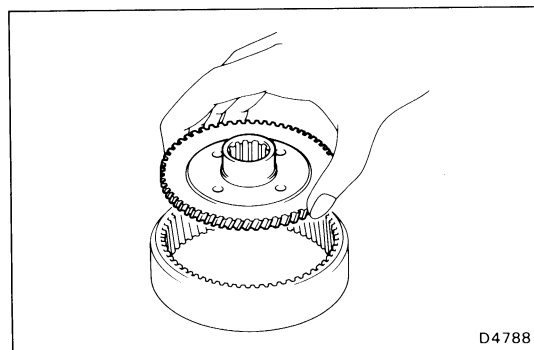

(b) Remove the ring gear flange.

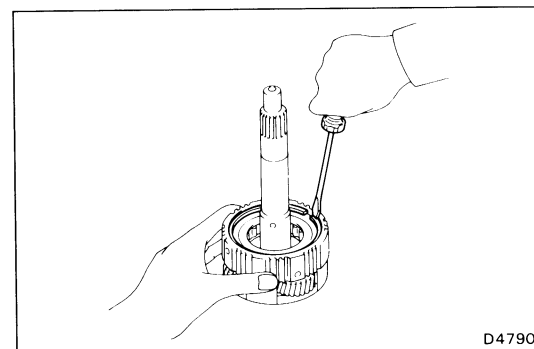
**8. REMOVE RETAINING PLATE**

(a) Remove the snap ring.

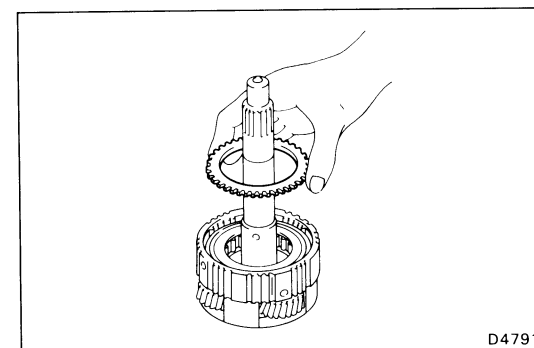

(b) Remove the retaining plate.

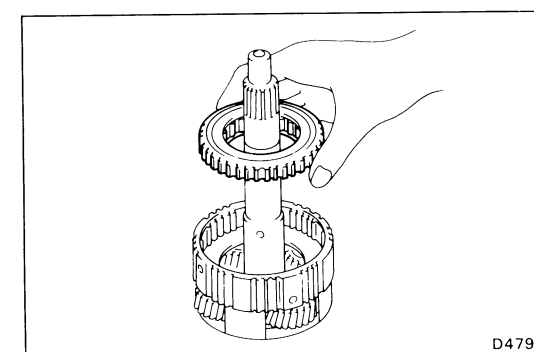
**9. REMOVE OVERDRIVE ONE-WAY CLUTCH WITH OUTER RACE**



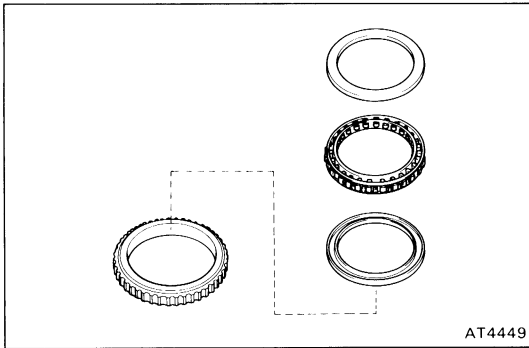

AT4449

**10. REMOVE ONE-WAY CLUTCH FROM OUTER RACE**

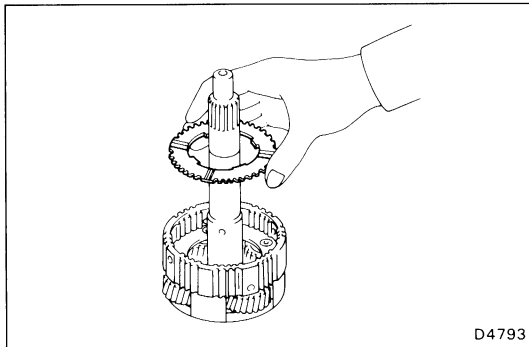

D4793

**11. REMOVE THRUST WASHER**

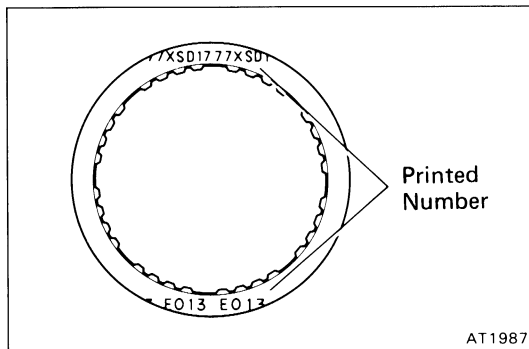

AT1987

**INSPECTION OF OVERDRIVE PLANETARY GEAR AND OVERDRIVE DIRECT CLUTCH**

**1. INSPECT DISC, PLATE AND FLANGE**

Check to see if the sliding surface of the disc, plate and flange are worn or burnt. If necessary, replace them.

**HINT:**

- If the lining of the disc is peeling off or discolored, or even if part of the printed numbers are defaced, replace all discs.
- Before assembling new discs, soak them in ATF for at least two hours.

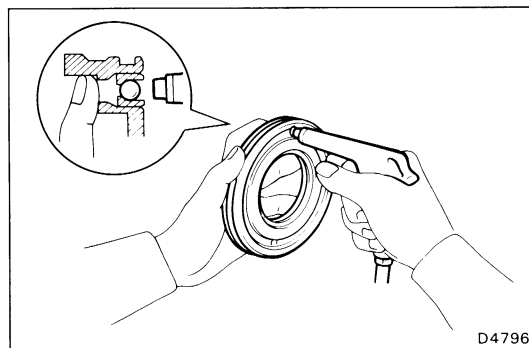

D4796

**2. CHECK OVERDRIVE DIRECT CLUTCH PISTON**

- (a) Check that check ball is free by shaking the piston.
- (b) Check that the valve does not leak by applying low-pressure compressed air.

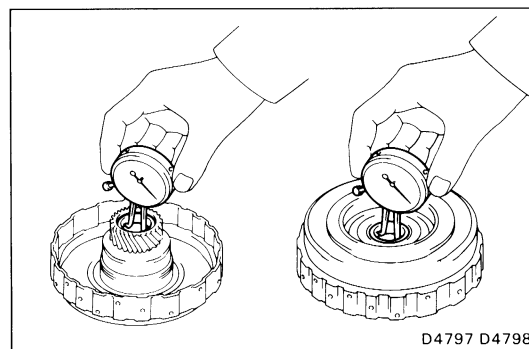

D4797 D4798

**3. CHECK OVERDRIVE DIRECT CLUTCH DRUM BUSHINGS**

Using a dial indicator, measure the inside diameter of the clutch drum bushings.

**Maximum inside diameter: 27.11 mm (1.0673 in.)**

If the inside diameter is greater than the maximum, replace the clutch drum.

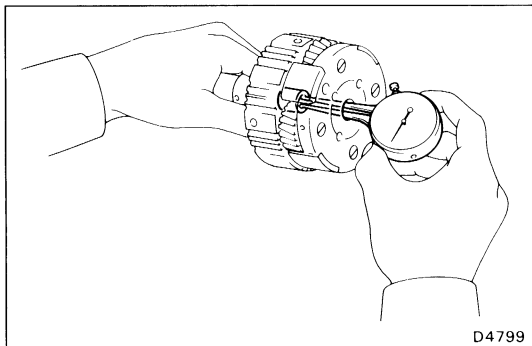

D4799

#### 4. CHECK OVERDRIVE PLANETARY GEAR BUSHING

Using a dial indicator, measure the inside diameter of the planetary gear bushing.

**Maximum inside diameter: 11.27 mm (0.4437 in.)**

If the inside diameter is greater than the maximum, replace the planetary gear.

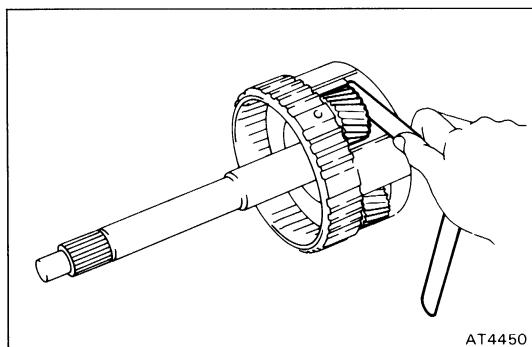

AT4450

#### 5. MEASURE PLANETARY PINION GEAR THRUST CLEARANCE

Using a feeler gauge, measure the planetary pinion gear thrust clearance.

**Standard clearance: 0.20 – 0.60 mm  
(0.0079 – 0.0236 in.)**

**Maximum clearance: 1.00 mm (0.0394 in.)**

If the clearance is greater than the maximum, replace the planetary gear assembly.

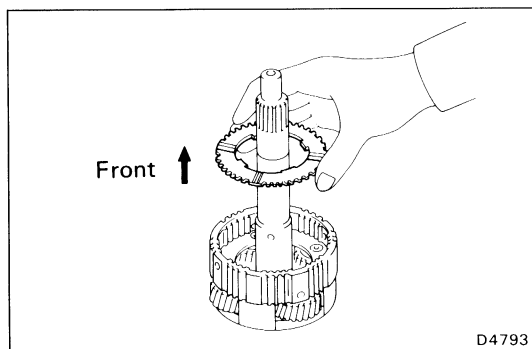

D4793

### ASSEMBLY OF OVERDRIVE PLANETARY GEAR, OVERDRIVE DIRECT CLUTCH AND OVERDRIVE ONE-WAY CLUTCH

#### 1. INSTALL THRUST WASHER TO OVERDRIVE PLANETARY GEAR

Install the thrust washer to the overdrive planetary gear, the grooved side facing upward.

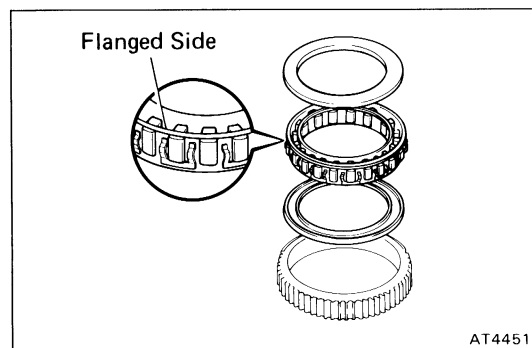

AT4451

#### 2. INSTALL OVERDRIVE ONE-WAY CLUTCH

(a) Install the one-way clutch into the outer race, the flanged side of the one-way clutch facing upward.

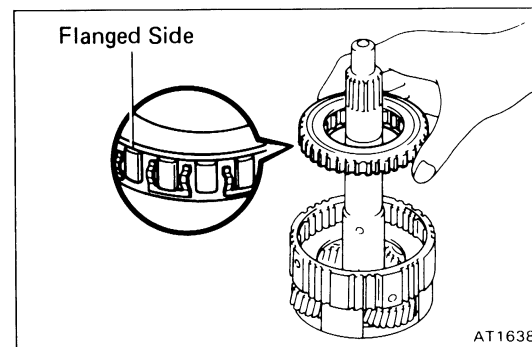

AT1638

(b) Install the overdrive one-way clutch with the outer race to the overdrive planetary gear.

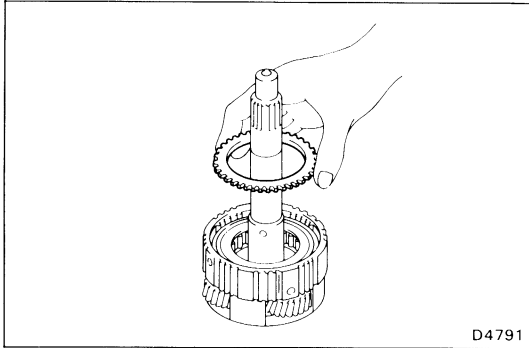
**3. INSTALL RETAINING PLATE**

- (a) Install the retaining plate.

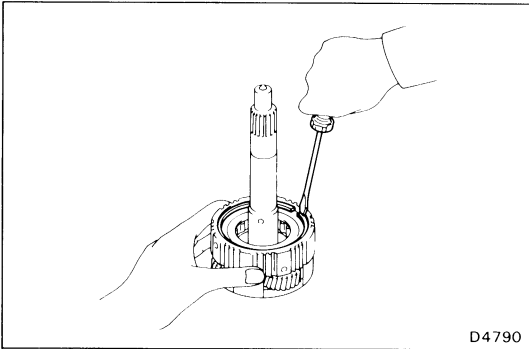

- (b) Install the snap ring.

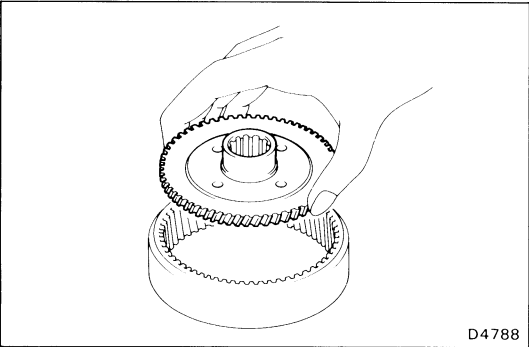
**4. INSTALL RING GEAR FLANGE TO OVERDRIVE PLANETARY RING GEAR**

- (a) Install the ring gear flange as shown.

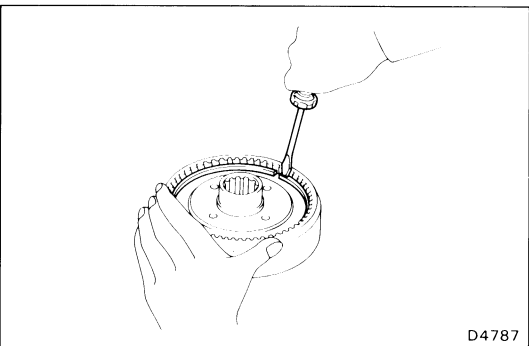

- (b) Install the snap ring.

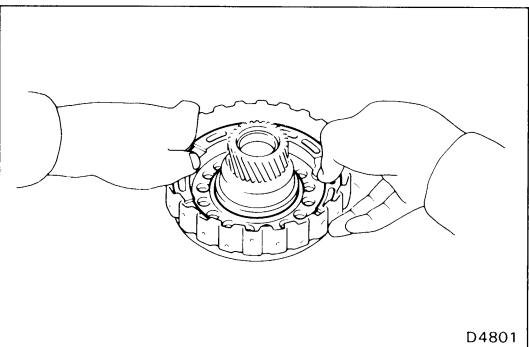
**5. INSTALL OVERDRIVE DIRECT CLUTCH PISTON**

- (a) Coat new O-rings with ATF and install them on the O/D direct clutch piston.
- (b) Being careful not to damage the O-rings, press in the direct clutch piston into the clutch drum with both hands.

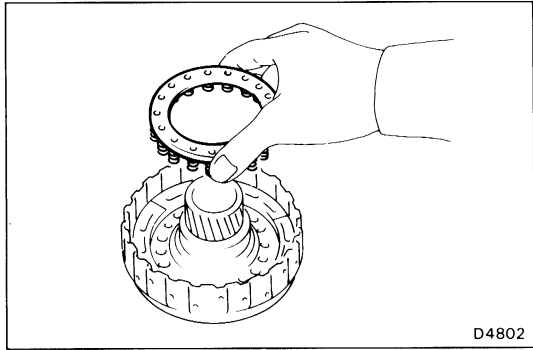

D4802

**6. INSTALL PISTON RETURN SPRING**

(a) Install the piston return spring to the piston.

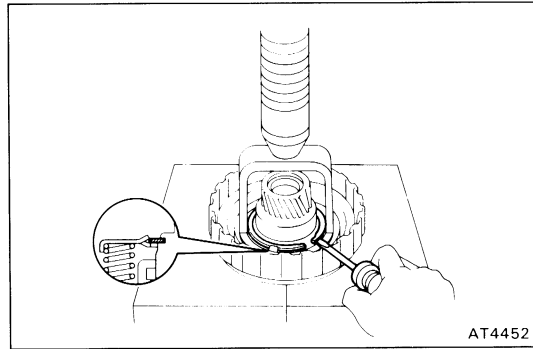

AT4452

(b) Place SST on the spring retainer, and compress the return spring with a shop press.

SST 09350-30020 (09350-07040)

(c) Install the snap ring with a screwdriver. Be sure the end gap of the snap ring is not aligned with the spring retainer claw.

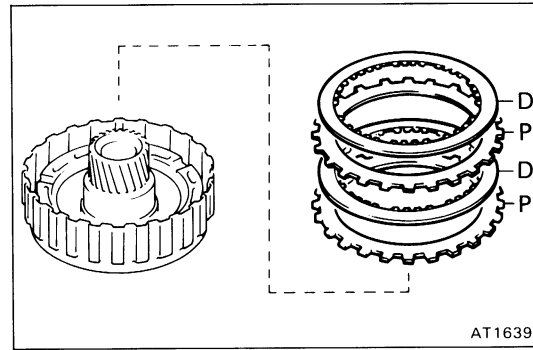

AT1639

**7. INSTALL PLATES, DISCS AND FLANGE**

(a) Install the plates and discs.

Install in order: P=Plate D=Disc  
P—D—P—D

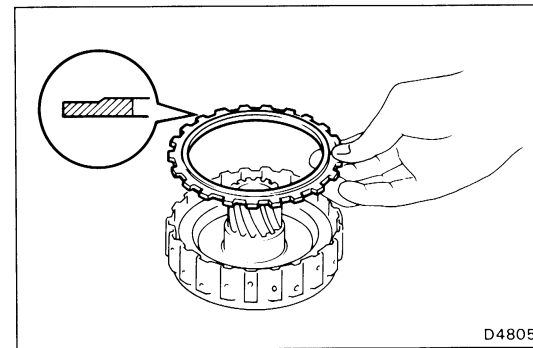

D4805

(b) Install the flange, the flat end facing downward.

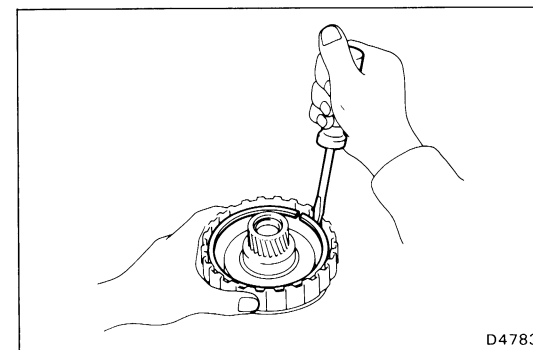

D4783

(c) Install the snap ring.

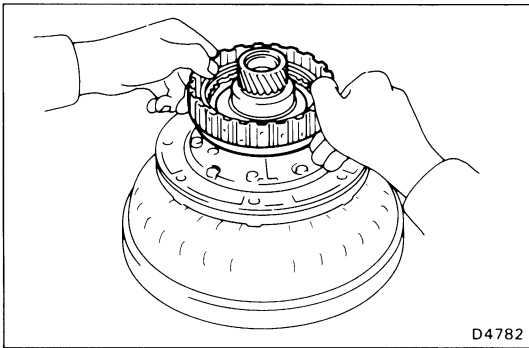

D4782

**8. CHECK PISTON STROKE OF OVERDRIVE DIRECT CLUTCH**

- (a) Place the oil pump onto the torque converter, and then place the O/D direct clutch assembly onto the oil pump.

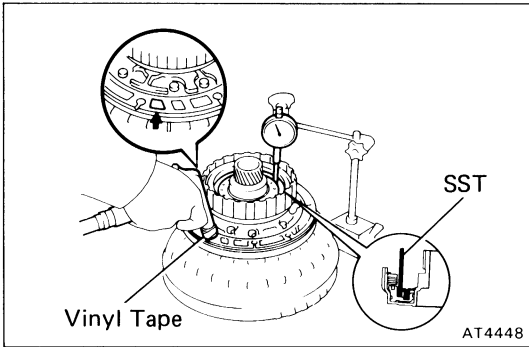

AT4448

- (b) Using SST and a dial indicator, measure the overdrive direct clutch piston stroke applying and releasing the compressed air (4 — 8 kg/cm<sup>2</sup>, 57 — 114 psi or 392 — 785 kPa) as shown.

SST 09350-30020 (09350-06120)

**Piston stroke: 1.85 — 2.15 mm (0.0728 — 0.0846 in.)**

If the piston stroke is less than the limit, parts may be mis-assembled and reinstall them.

If the piston stroke is nonstandard, select another flange.

**NOTE:** There are six different thicknesses for the flange.

Flange thickness mm (in.)

No.	Thickness	No.	Thickness
16	3.6 (0.142)	19	3.3 (0.130)
17	3.5 (0.138)	20	3.2 (0.126)
18	3.4 (0.134)	21	3.1 (0.122)

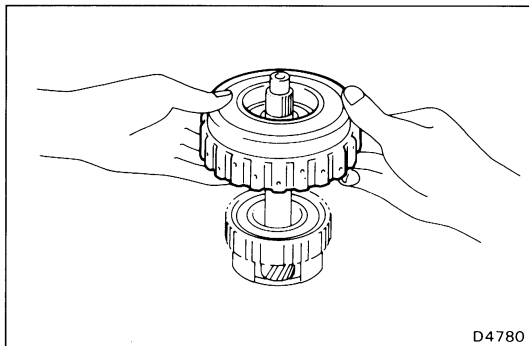

D4780

**9. INSTALL OVERDRIVE DIRECT CLUTCH ASSEMBLY**

- (a) Align the flukes of discs in the direct clutch.
- (b) Install the direct clutch assembly onto the O/D planetary gear.

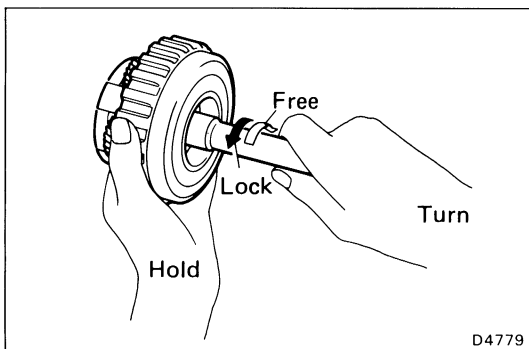

D4779

**10. CHECK OPERATION OF ONE-WAY CLUTCH**

Hold the O/D direct clutch drum and turn the input shaft. The input shaft turns freely clockwise and locks counter-clockwise.

# Overdrive Brake COMPONENTS

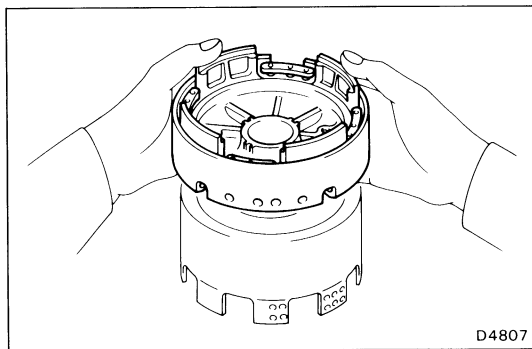
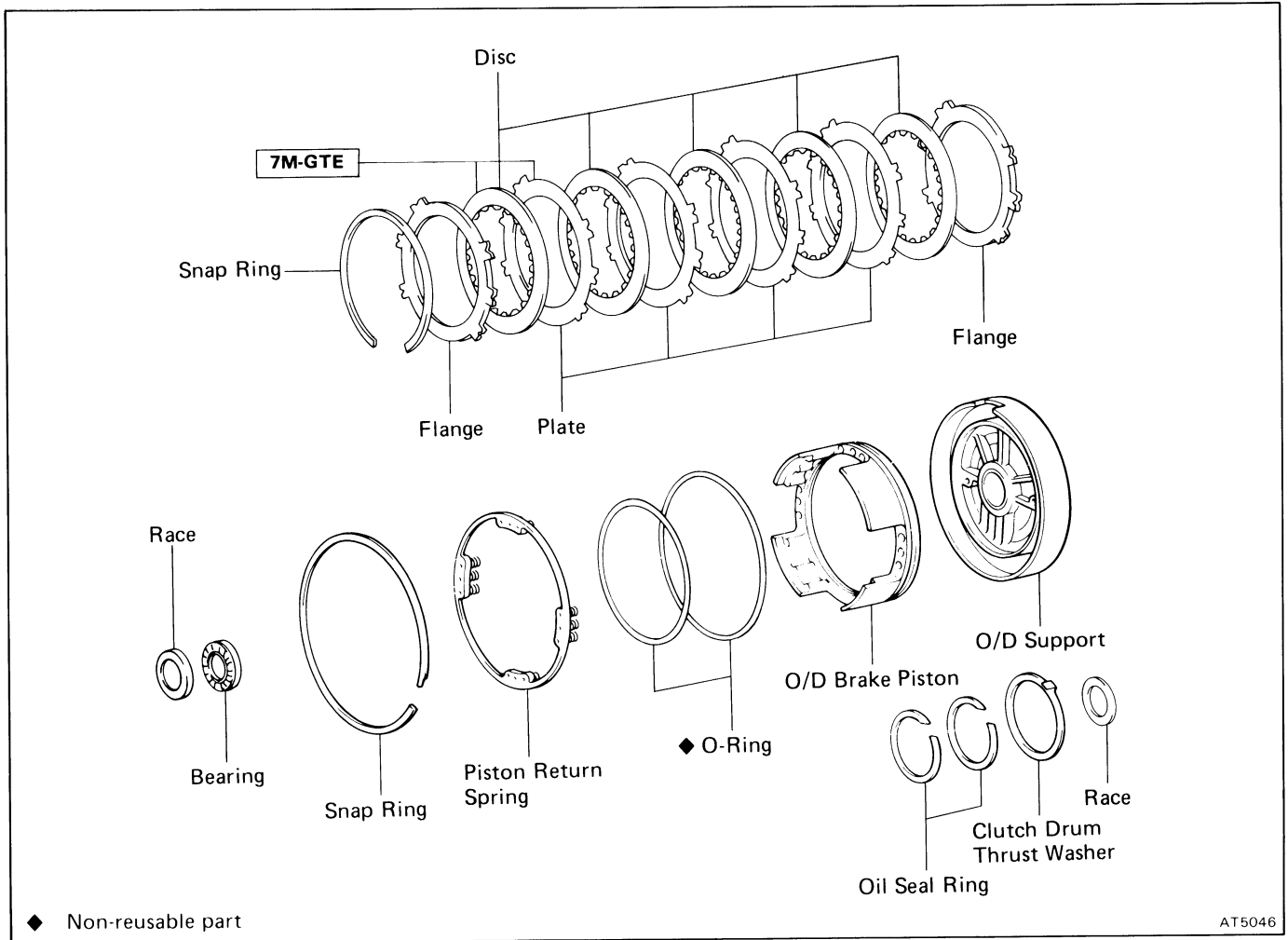

## DISASSEMBLY OF OVERDRIVE BRAKE

### 1. CHECK OVERDRIVE BRAKE PISTON MOVING

(a) Place the O/D support assembly onto the direct clutch assembly.

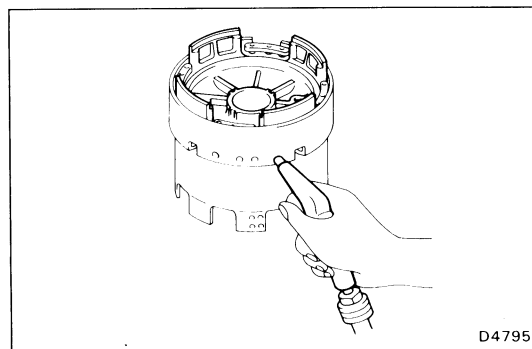

(b) Apply compressed air into the oil passage as shown, and be sure that the O/D brake piston moves smoothly.

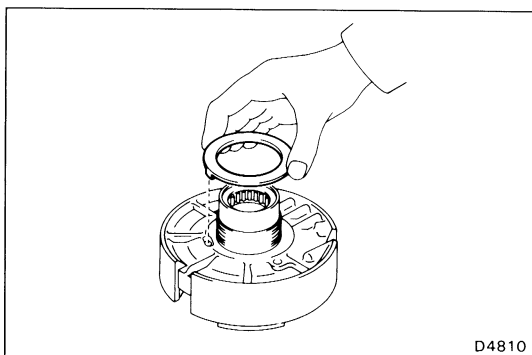

**2. REMOVE CLUTCH DRUM THRUST WASHER FROM OVER-DRIVE SUPPORT**

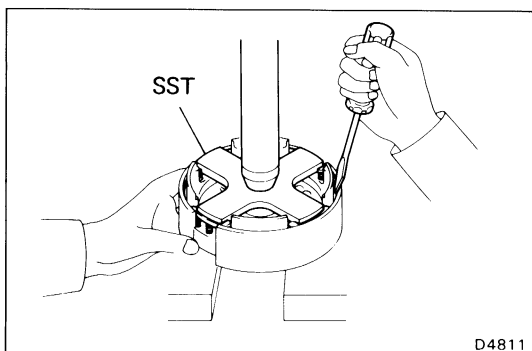

**3. REMOVE PISTON RETURN SPRING**

- (a) Place SST on the spring retainer, and compress the return spring with a shop press.

SST 09350-30020 (09350-07030)

- (b) Remove the snap ring with a screwdriver.
- (c) Remove the piston return spring.

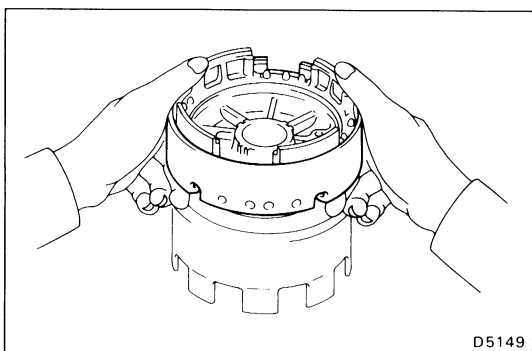

**4. REMOVE OVERDRIVE BRAKE PISTON**

- (a) Place the O/D support onto the direct clutch assembly.

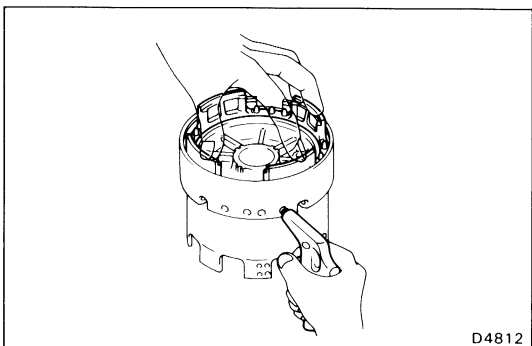

- (b) Hold the O/D brake piston so it does not slant and apply compressed air into the passage to remove the O/D brake piston.

- (c) Remove the O/D brake piston.
- (d) Remove the two O-rings from the piston.

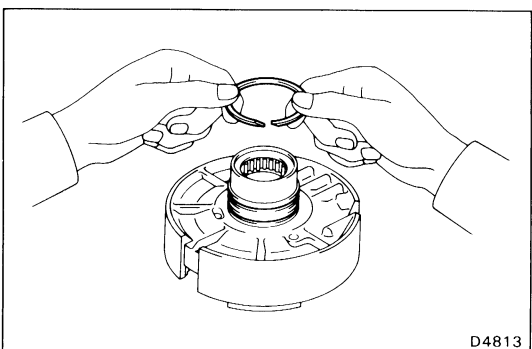

**5. REMOVE OIL SEAL RINGS**

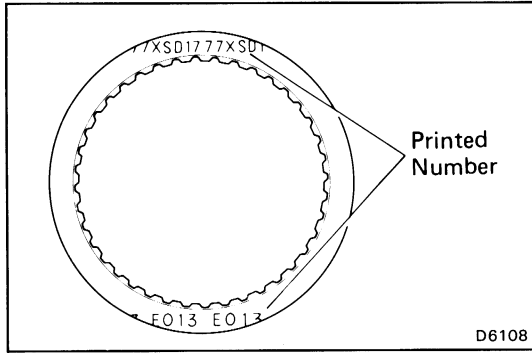

## INSPECTION OF OVERDRIVE BRAKE

### INSPECT DISC, PLATE AND FLANGE

Check to see if the sliding surface of the disc, plate and flange are worn or burnt. If necessary, replace them.

#### HINT:

- If the lining of the disc is peeling off or discolored, or even if parts of the printed numbers are defaced, replace all discs.
- Before assembling new discs, soak them in ATF for at least two hours.

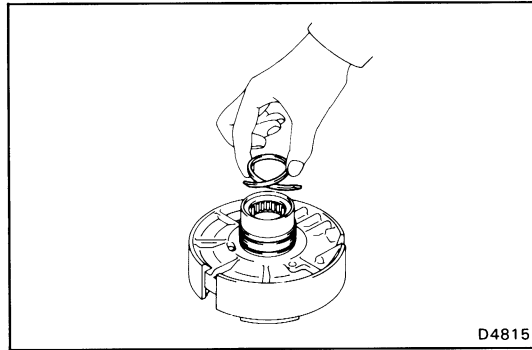

## ASSEMBLY OF OVERDRIVE BRAKE

### 1. INSTALL OIL SEAL RINGS

- Coat the two oil seal rings with ATF.
- Contract the oil seal rings as shown, and install them onto the O/D support.

**NOTICE:** Do not spread the ring ends more than necessary.

**HINT:** After installing the oil seal rings, check that they rotate smoothly.

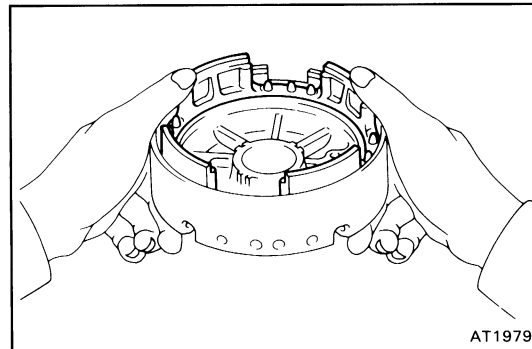

### 2. INSTALL OVERDRIVE BRAKE PISTON

- Coat two new O-rings with ATF and install them on the O/D brake piston.
- Being careful not to damage the O-rings, press in the brake piston into the O/D support with both hands.

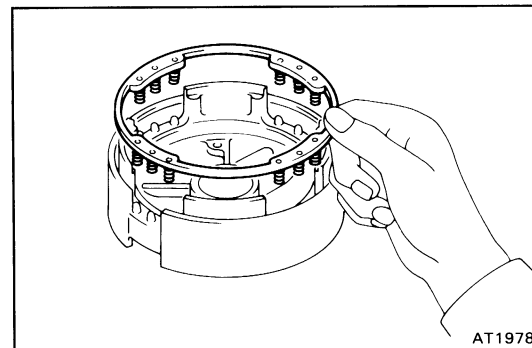

### 3. INSTALL PISTON RETURN SPRING

- Install the piston return spring.

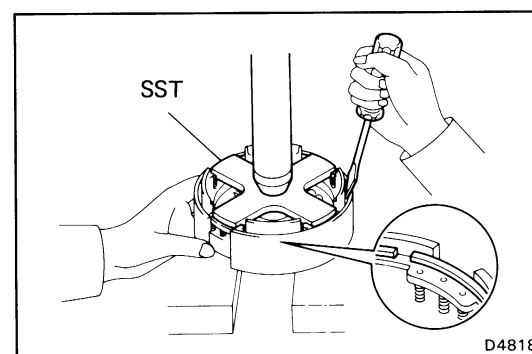

- Place SST on the spring retainer, and compress the return spring with a shop press.

SST 09350-30020 (09350-07030)

- Install the snap ring with a screwdriver. Be sure the end gap of the snap ring is not aligned with the cutout portion of the O/D support.

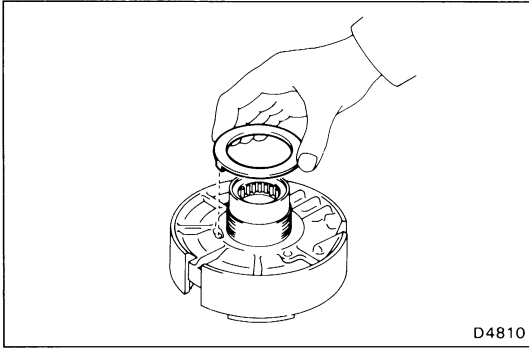

**4. INSTALL CLUTCH DRUM THRUST WASHER**

Coat the thrust washer with petroleum jelly and install it onto the O/D support.

**HINT:** Make sure that the lug shape matches the hole on the O/D support.

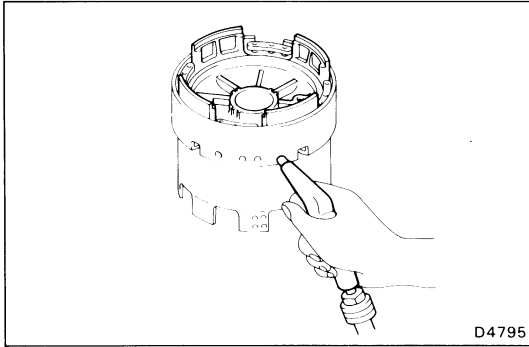
**5. CHECK OVERDRIVE BRAKE PISTON MOVING**

- (a) Place the O/D support assembly onto the direct clutch assembly.
- (b) Apply compressed air into the oil passage as shown, and be sure that the O/D brake piston moves smoothly.

# Direct Clutch COMPONENTS

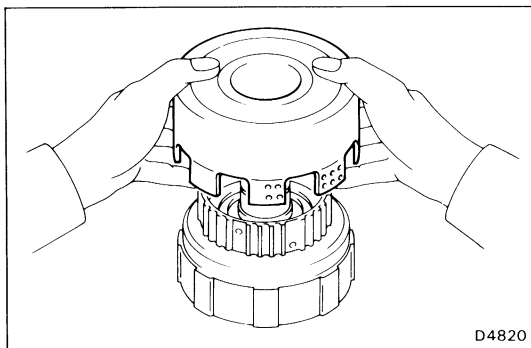
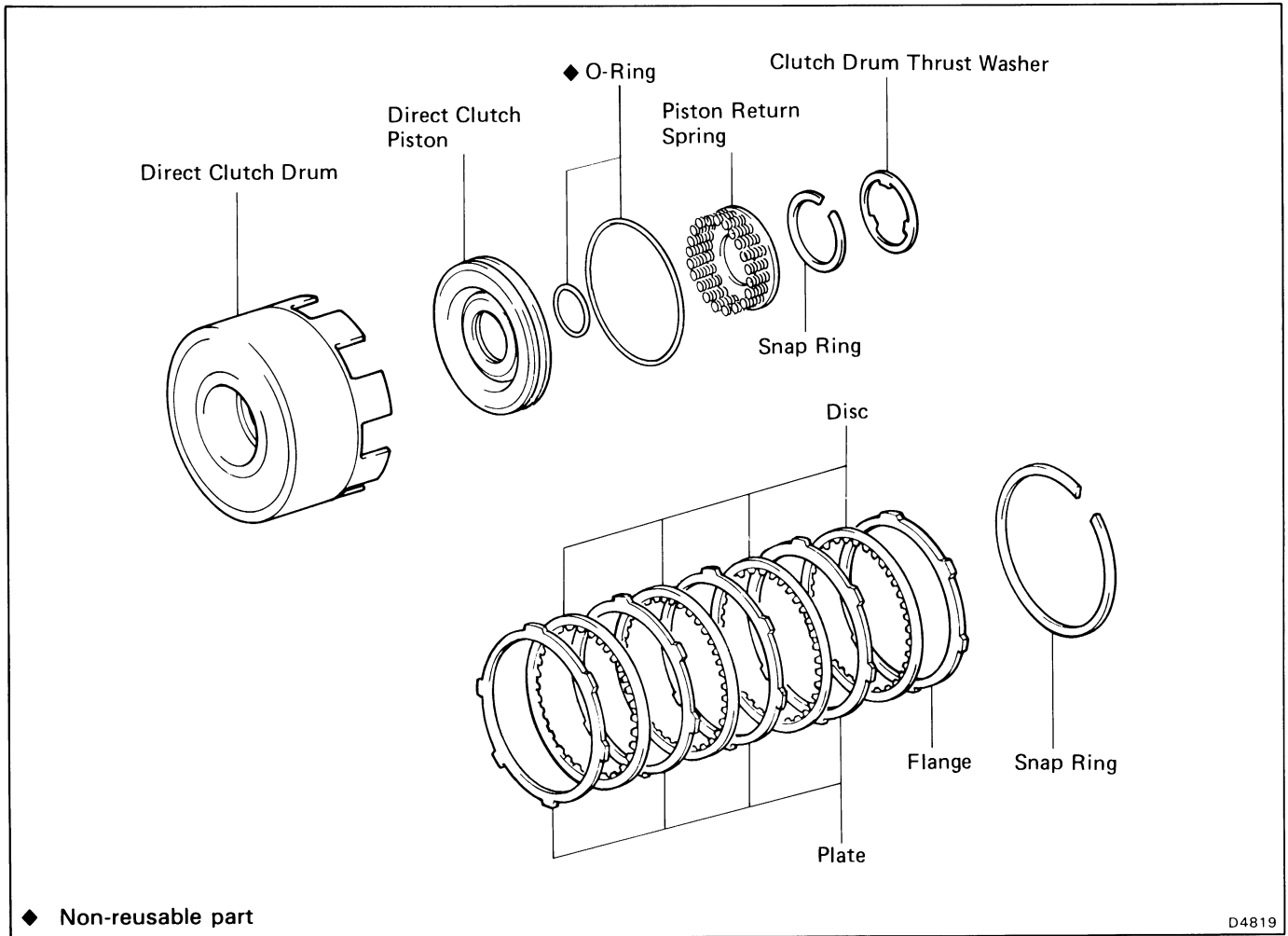

## DISASSEMBLY OF DIRECT CLUTCH

1. REMOVE DIRECT CLUTCH DRUM ASSEMBLY FROM FORWARD CLUTCH ASSEMBLY

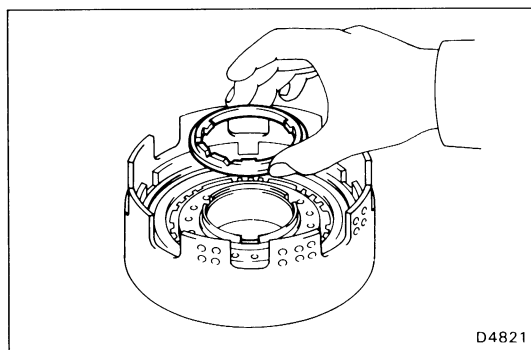

2. REMOVE CLUTCH DRUM THRUST WASHER FROM DIRECT CLUTCH ASSEMBLY

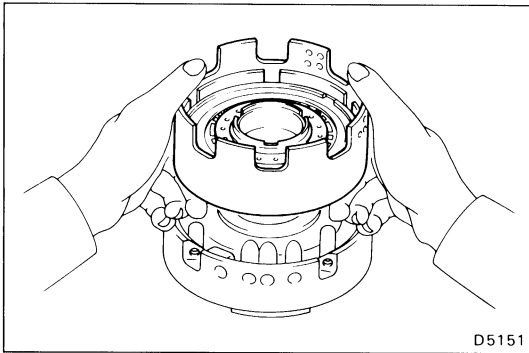

D5151

### 3. CHECK PISTON STROKE OF DIRECT CLUTCH

- (a) Place the direct clutch assembly onto the O/D support assembly.

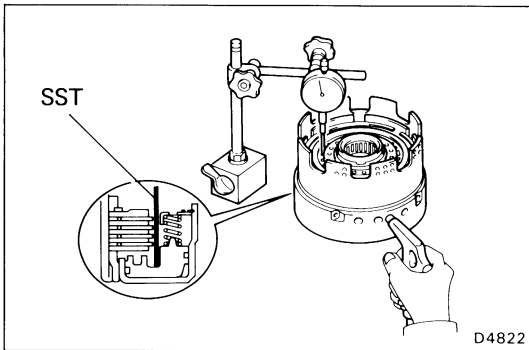

D4822

- (b) Using SST and a dial indicator, measure the direct clutch piston stroke applying and releasing the compressed air (4 — 8 kg/cm<sup>2</sup>, 57 — 114 psi or 392 — 785 kPa) as shown.

SST 09350-30020 (09350-06120)

**Piston stroke: 1.37 — 1.60 mm (0.0539 — 0.0630 in.)**

If the values are nonstandard, inspect the discs.

### 4. REMOVE FLANGE, PLATES AND DISCS

- (a) Remove the snap ring from the direct clutch drum.  
 (b) Remove the flange, four plates and four discs.

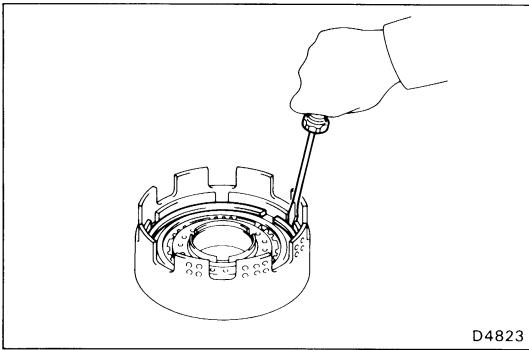

D4823

### 5. REMOVE PISTON RETURN SPRING

- (a) Place SST on the spring retainer and compress the return spring with a shop press.

SST 09350-30020 (09350-07040)

- (b) Using snap ring pliers, remove the snap ring.  
 (c) Remove the piston return spring.

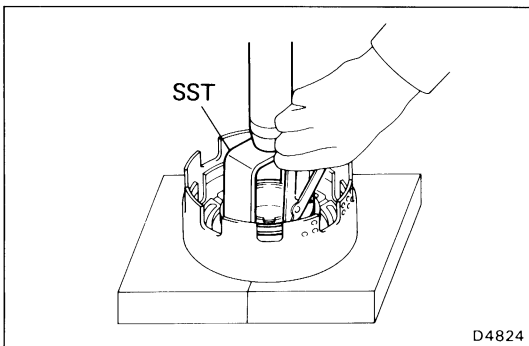

D4824

### 6. REMOVE DIRECT CLUTCH PISTON

- (a) Place the direct clutch drum onto the O/D support.  
 (b) Hold the direct clutch piston with hand, apply compressed air to the O/D support to remove the direct clutch piston.  
 (c) Remove the direct clutch piston.  
 (d) Remove the two O-rings from the piston.

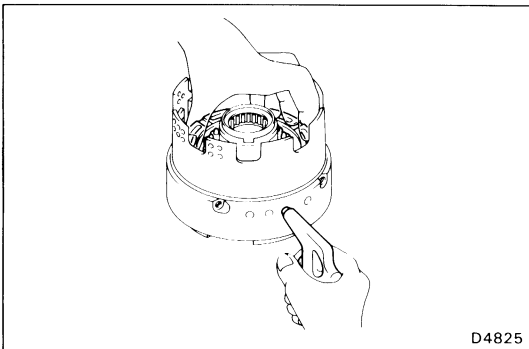

D4825

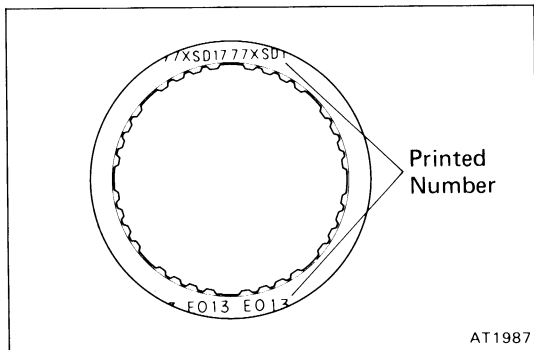

## INSPECTION OF DIRECT CLUTCH

### 1. INSPECT DISC, PLATE AND FLANGE

Check to see if the sliding surface of the disc, plate and flange are worn or burnt. If necessary, replace them.

#### HINT:

- If the lining of the disc is peeling off or discolored, or even if parts of the printed numbers are defaced, replace all discs.
- Before assembling new discs, soak them in ATF for at least two hours.

### 2. CHECK DIRECT CLUTCH PISTON

- Check that check ball is free by shaking the piston.
- Check that the valve does not leak by applying low-pressure compressed air.

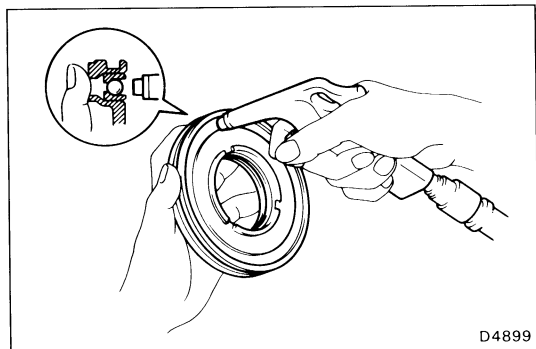

### 3. CHECK DIRECT CLUTCH DRUM BUSHING

Using a dial indicator, measure the inside diameter of the clutch drum bushing.

**Maximum inside diameter: 53.99 mm (2.1256 in.)**

If the inside diameter is greater than the maximum, replace the clutch drum.

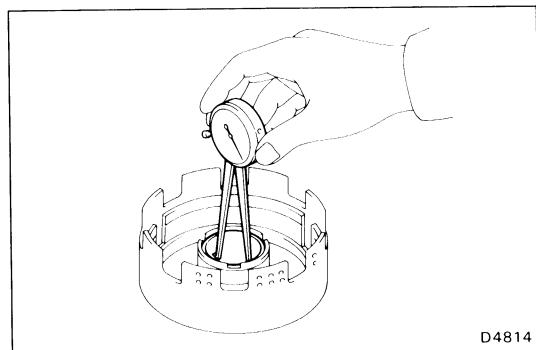

## ASSEMBLY OF DIRECT CLUTCH

### 1. INSTALL DIRECT CLUTCH PISTON TO DIRECT CLUTCH DRUM

- Coat new O-rings with ATF and install them on the direct clutch piston.
- Being careful not to damage the O-rings, press in the direct clutch piston into the clutch drum with both hands.

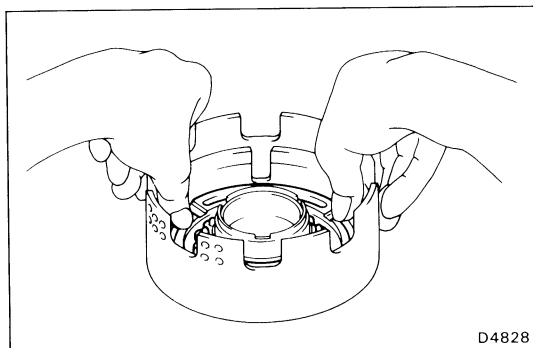

### 2. INSTALL PISTON RETURN SPRING

- Install the piston return spring.

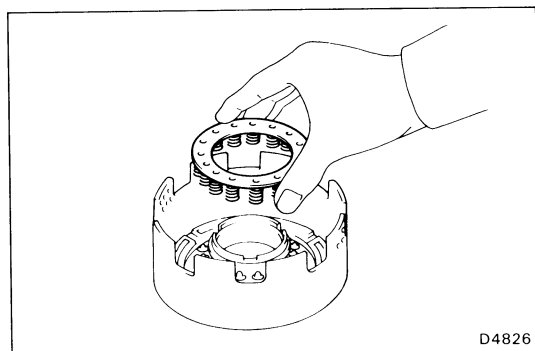

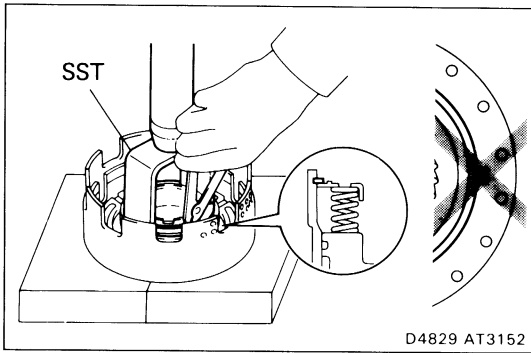

(b) Place SST on the spring retainer, and compress the return spring with a shop press.

SST 09350-30020 (09350-07040)

(c) Install the snap ring with snap ring pliers. Be sure the end gap of the snap ring is not aligned with the spring retainer claw.

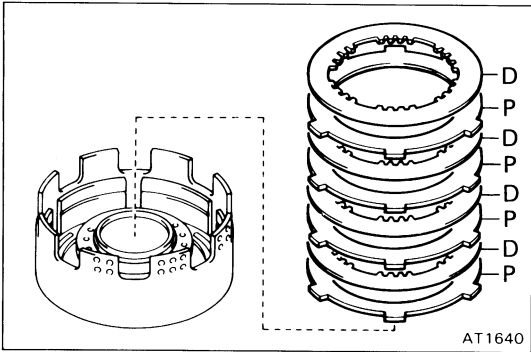

**3. INSTALL PLATES, DISCS AND FLANGE**

(a) Install the plates and discs.

Install in order: P=Plate D=Disc  
P-D-P-D-P-D-P-D

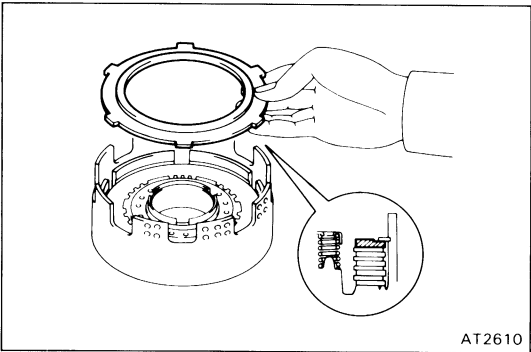

(b) Install the flange, the flat end facing downward.

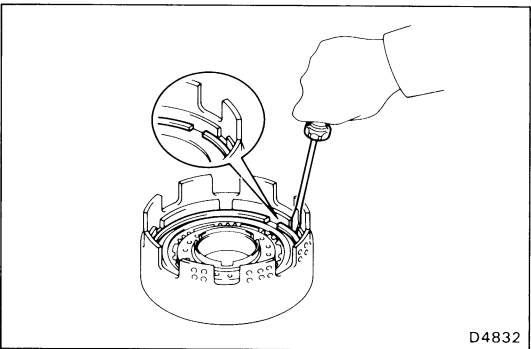

(c) Install the snap ring with a screwdriver. Be sure the end gap of the snap ring is not aligned with the cutout portion of the direct clutch drum.

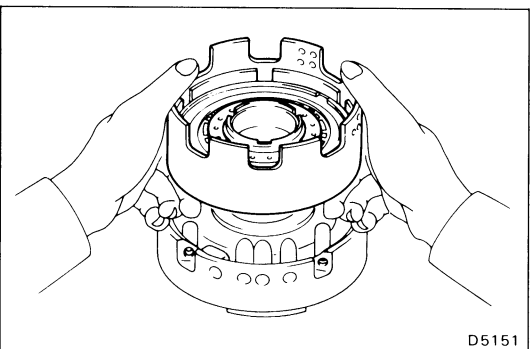

**4. CHECK PISTON STROKE OF DIRECT CLUTCH**

(a) Place the direct clutch assembly onto the O/D support assembly.

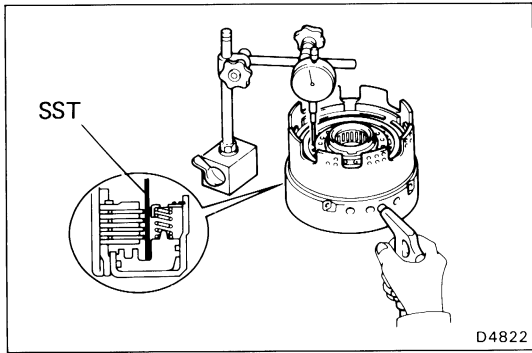

D4822

(b) Using SST and a dial indicator, measure the direct clutch piston stroke applying and releasing the compressed air (4 – 8 kg/cm<sup>2</sup>, 57 – 114 psi or 392 – 785 kPa) as shown.

SST 09350-30020 (09350-06120)

**Piston stroke: 1.37 – 1.60 mm (0.0539 – 0.0630 in.)**

If the piston stroke is less than the limit, parts may have been assembled incorrectly, check and reassemble again.

If the piston stroke is nonstandard, select another flange.

**HINT:** There are eight different thicknesses for the flange.

Flange thickness		mm (in.)	
No.	Thickness	No.	Thickness
33	3.0 (0.118)	29	3.4 (0.134)
32	3.1 (0.122)	28	3.5 (0.138)
31	3.2 (0.126)	27	3.6 (0.142)
30	3.3 (0.130)	34	3.7 (0.146)

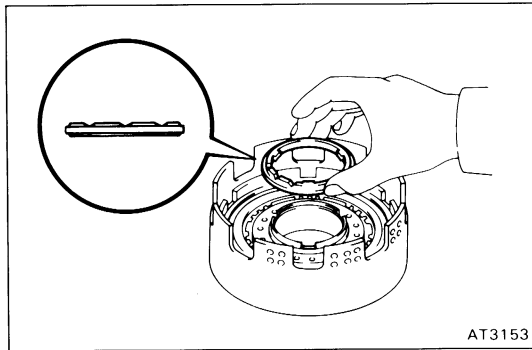

AT3153

**5. INSTALL CLUTCH DRUM THRUST WASHER**

Coat the thrust washer with petroleum jelly and install it onto the direct clutch.

**HINT:** Make sure that the lug shapes match the cutout portions on the direct clutch.

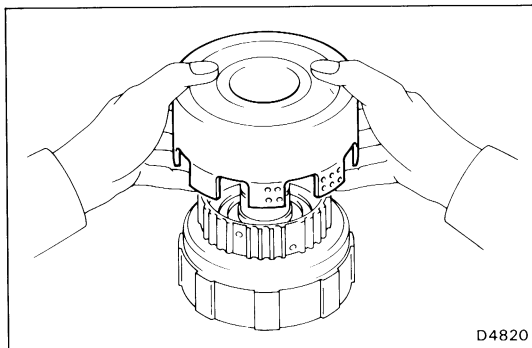

D4820

**6. INSTALL DIRECT CLUTCH ASSEMBLY TO FORWARD CLUTCH ASSEMBLY**

- (a) Align the flukes of discs in the direct clutch.
- (b) Install the direct clutch assembly onto the forward clutch assembly.

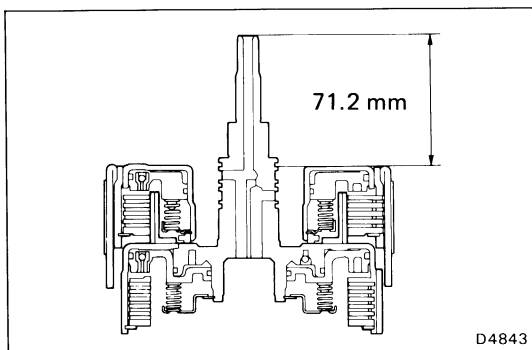

D4843

(c) Check that the distance from the direct clutch end to the forward clutch end is 71.2 mm (2.803 in.).

If the distance is less than the above value, parts may have been assembled incorrectly, check and reassemble again.

# Forward Clutch COMPONENTS

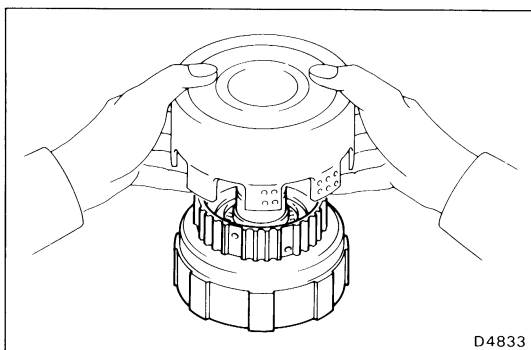
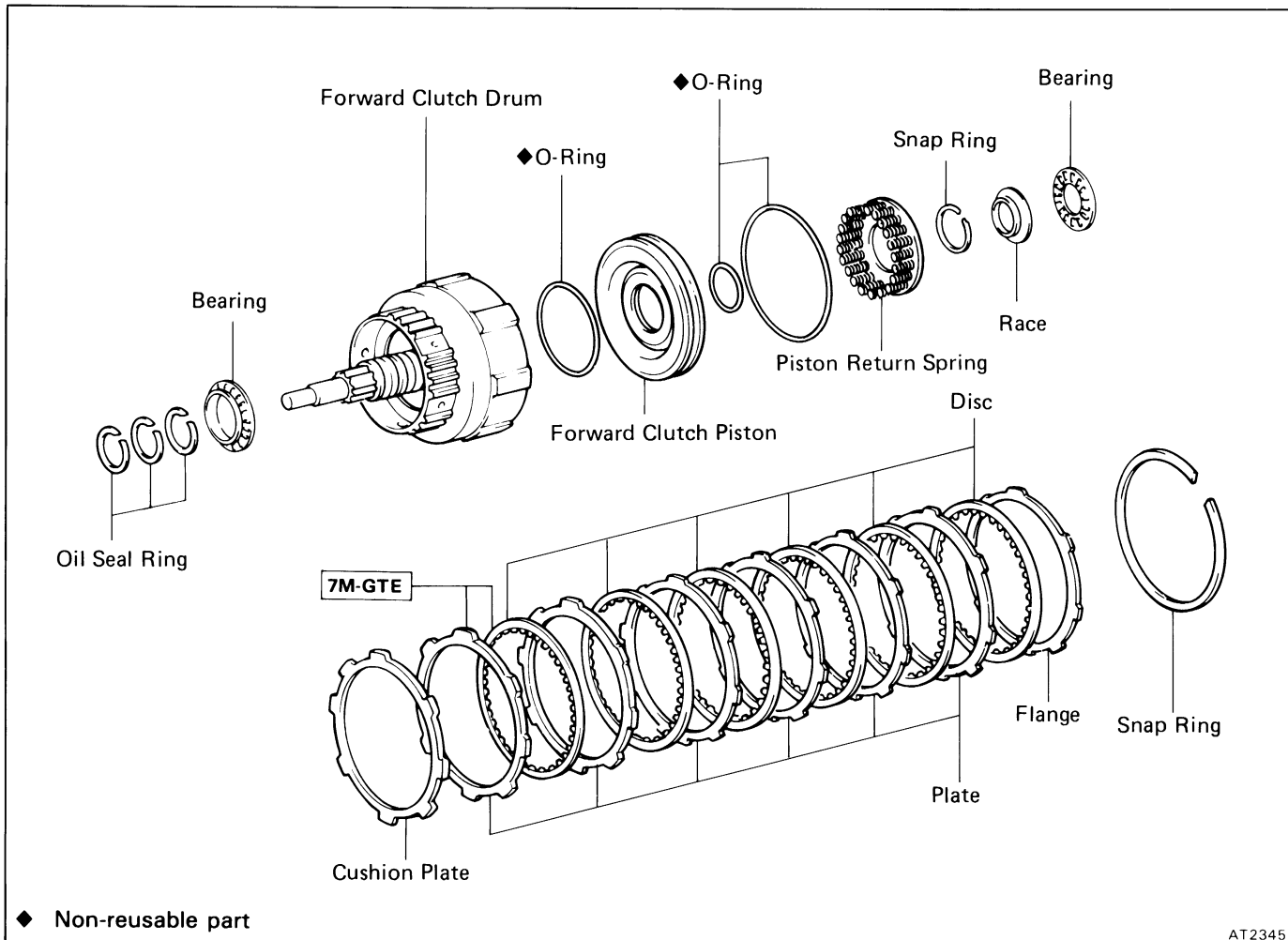

## DISASSEMBLY OF FORWARD CLUTCH

1. REMOVE FORWARD CLUTCH ASSEMBLY FROM DIRECT CLUTCH ASSEMBLY

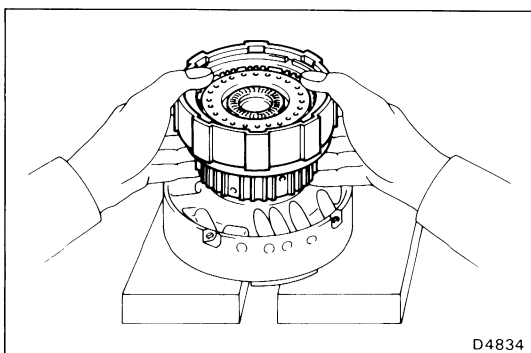

2. PLACE FORWARD CLUTCH ONTO OVERDRIVE SUPPORT
  - (a) Place wooden blocks, etc. to prevent forward clutch shaft from touching the work stand, and place the O/D support on them.
  - (b) Place the forward clutch onto the O/D support.

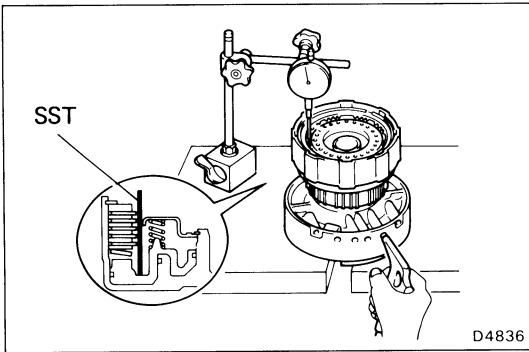

### 3. CHECK PISTON STROKE OF FORWARD CLUTCH

Using SST and a dial indicator, measure the forward clutch piston stroke applying and releasing the compressed air (4 — 8 kg/cm<sup>2</sup>, 57 — 114 psi or 392 — 785 kPa) as shown.

SST 09350-30020 (09350-06120)

Piston stroke:

7M-GE 3.42 — 3.93 mm (0.1346 — 0.1547 in.)

7M-GTE 3.73 — 4.59 mm (0.1469 — 0.1807 in.)

If the values are nonstandard, inspect the discs.

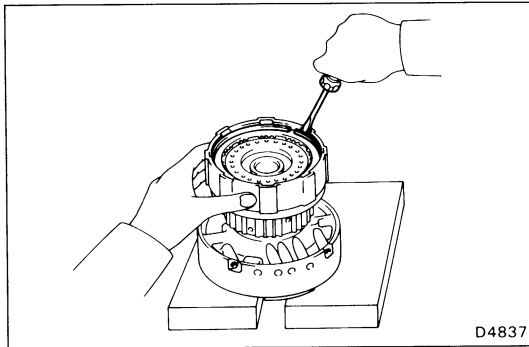

### 4. REMOVE FLANGE, PLATES AND DISCS

(a) Remove the snap ring from the forward clutch drum.

(b) Remove the flange, plates and discs.

7M-GE: One flange, five plates and five discs

7M-GTE: One flange, six plates and six discs

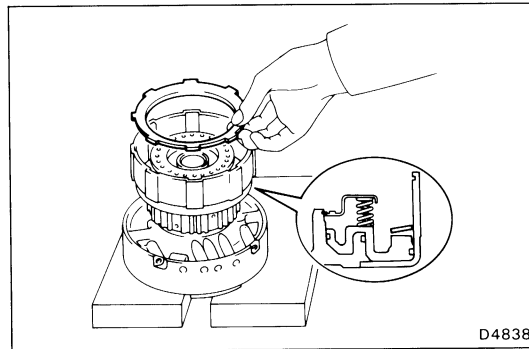

### 5. REMOVE CUSHION PLATE

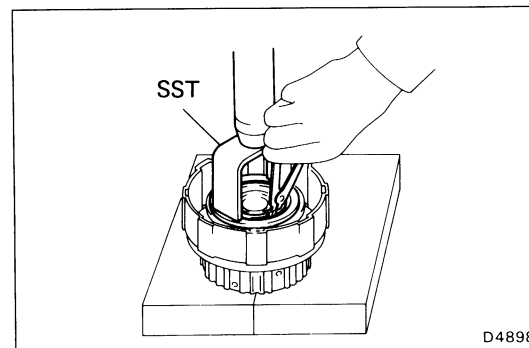

### 6. REMOVE PISTON RETURN SPRING

(a) Place SST on the spring retainer and compress the return spring with a shop press.

SST 09350-30020 (09350-07040)

(b) Using snap ring pliers, remove the snap ring.

(c) Remove the piston return spring.

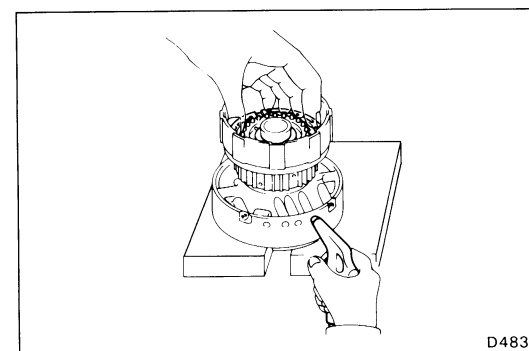

### 7. REMOVE FORWARD CLUTCH PISTON

(a) Place the forward clutch drum onto the O/D support.

(b) Hold the forward clutch piston with hand, apply compressed air to the O/D support to remove the forward clutch piston.

(c) Remove the forward clutch piston.

(d) Remove the two O-rings from the piston.



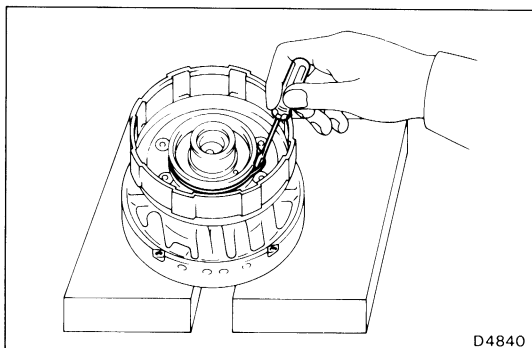

## 8. REMOVE O-RING FROM FORWARD CLUTCH DRUM

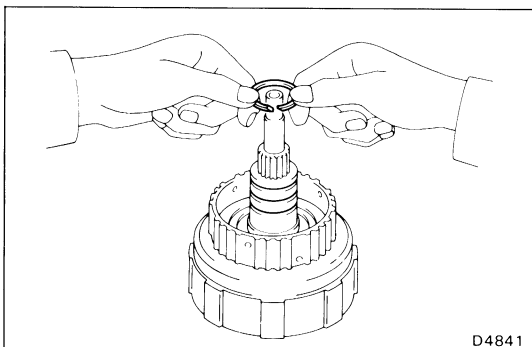

## 9. REMOVE OIL SEAL RINGS

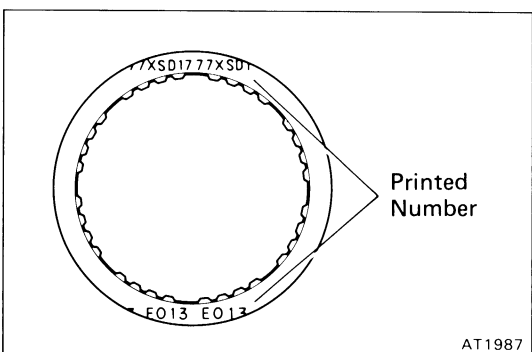

## INSPECTION OF FORWARD CLUTCH

### 1. INSPECT DISC, PLATE AND FLANGE

Check to see if the sliding surface of the disc, plate and flange are worn or burnt. If necessary, replace them.

#### HINT:

- If the lining of the disc is peeling off or discolored, or even if part of the printed numbers are defaced, replace all discs.
- Before assembling new discs, soak them in ATF for at least two hours.

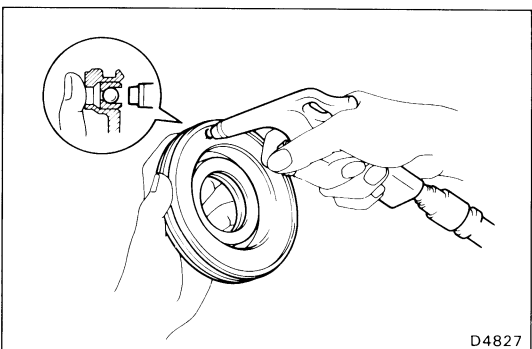

### 2. CHECK FORWARD CLUTCH PISTON

- Check that check ball is free by shaking the piston.
- Check that the valve does not leak by applying low-pressure compressed air.

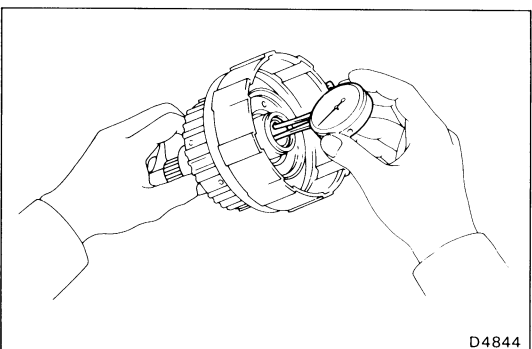

### 3. CHECK FORWARD CLUTCH DRUM BUSHING

Using a dial indicator, measure the inside diameter of the forward clutch drum bushing.

**Maximum inside diameter: 24.08 mm (0.9480 in.)**

If the inside diameter is greater than the maximum, replace the forward clutch drum.

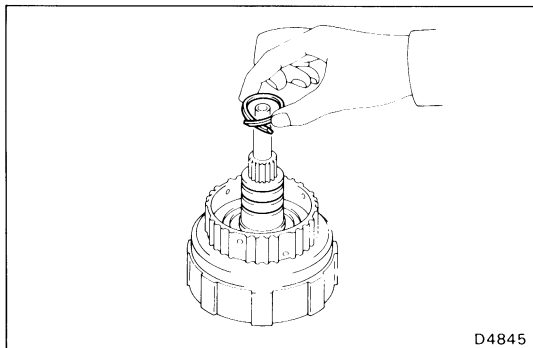

D4845

## ASSEMBLY OF FORWARD CLUTCH

### 1. INSTALL OIL SEAL RINGS

- (a) Coat the three oil seal rings with ATF.
- (b) Contract the oil seal rings as shown, and install them onto the forward clutch drum.

**NOTICE:** Do not spread the ring ends more than necessary.

**HINT:** After installing the oil seal rings, check that they rotate smoothly.

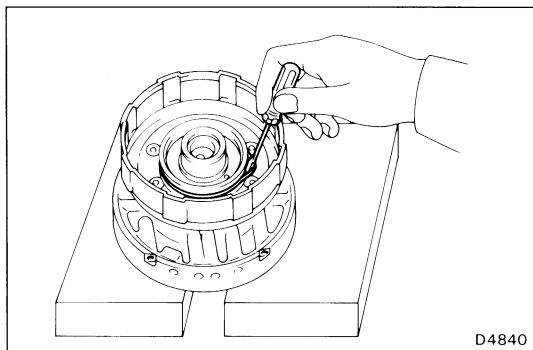

D4840

### 2. INSTALL NEW O-RING TO FORWARD CLUTCH DRUM

Coat a new O-ring with ATF and install it on the forward clutch drum.

### 3. INSTALL FORWARD CLUTCH PISTON

- (a) Coat new O-rings with ATF and install them on the forward clutch piston.

- (b) Being careful not to damage the O-rings, press the clutch piston into the forward clutch drum with both hands.

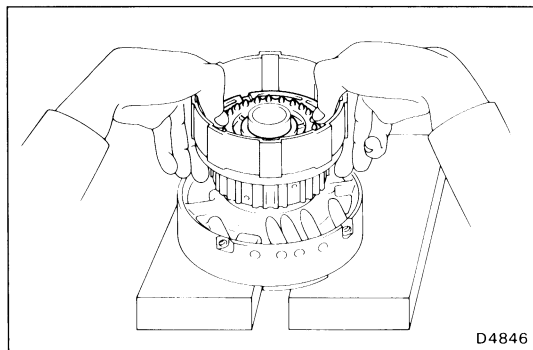

D4846

### 4. INSTALL PISTON RETURN SPRING

- (a) Install the piston return spring.

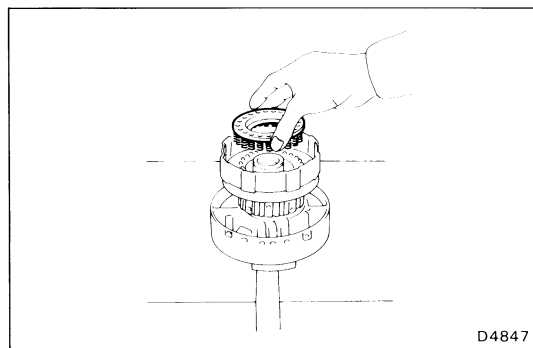

D4847

- (b) Place SST on the spring retainer, and compress the return spring with a shop press.

SST 09350-30020 (09350-07040)

- (c) Install the snap ring with snap ring pliers. Be sure the end gap of the snap ring is not aligned with the spring retainer claw.

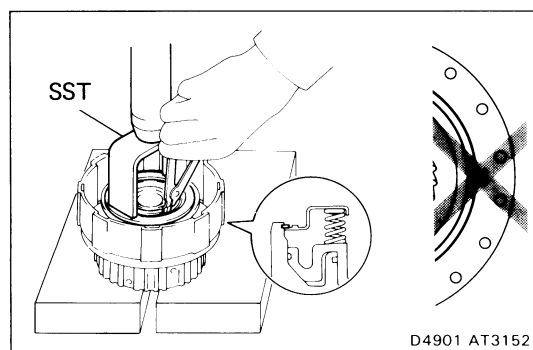

D4901 AT3152

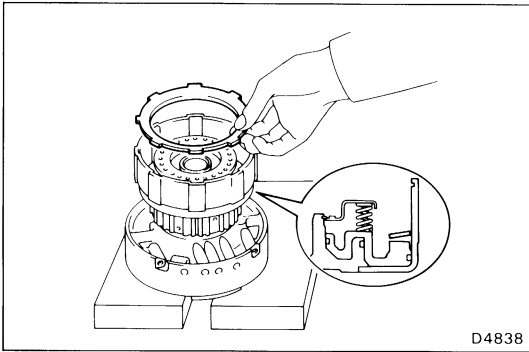

5. INSTALL CUSHION PLATE ROUNDED END DOWN AS SHOWN

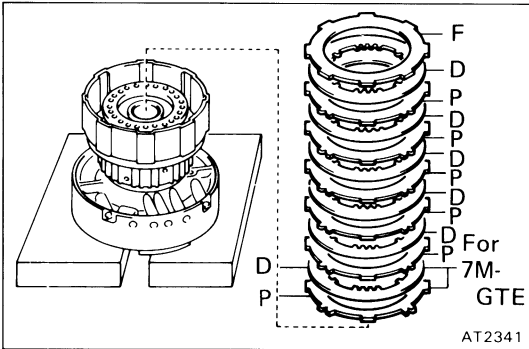

6. INSTALL PLATES, DISCS AND FLANGE

- (a) Install in order: P=Plate D=Disc  
 7M-GE: P-D-P-D-P-D-P-D-P-D  
 7M-GTE: P-D-P-D-P-D-P-D-P-D-P-D
- (b) And then install the flange, the rounded edge facing downward.

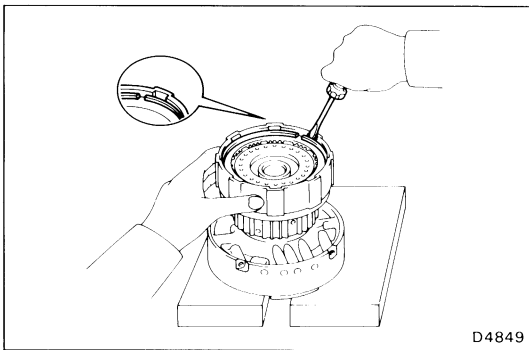

- (c) Install the snap ring with a screwdriver. Be sure the end gap of the snap ring is not aligned with the cutout portion of the forward clutch drum.

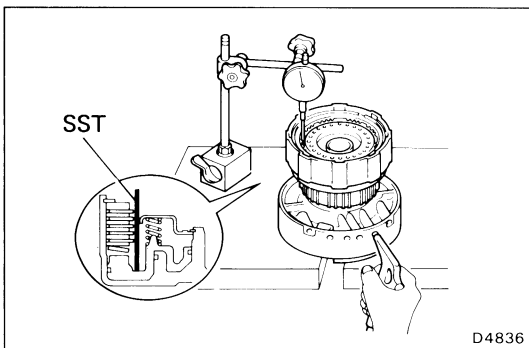

7. CHECK PISTON STROKE OF FORWARD CLUTCH

Using SST and a dial indicator, measure the forward clutch piston stroke applying and releasing the compressed air (4 — 8 kg/cm<sup>2</sup>, 57 — 114 psi or 392 — 785 kPa) as shown. SST 09350-30020 (09350-06120)

Piston stroke:

- 7M-GE 3.42 — 3.93 mm (0.1346 — 0.1547 in.)
- 7M-GTE 3.73 — 4.59 mm (0.1469 — 0.1807 in.)

If the piston stroke is less than the limit, parts may have been assembled incorrectly, check and reassemble again.

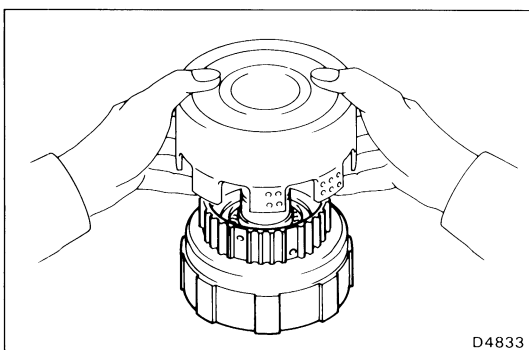

8. INSTALL DIRECT CLUTCH ASSEMBLY TO FORWARD CLUTCH ASSEMBLY

- (a) Make sure that the thrust washer is installed to the direct clutch drum.
- (b) Align the flukes of discs in the direct clutch.
- (c) Install the direct clutch assembly onto the forward clutch assembly.

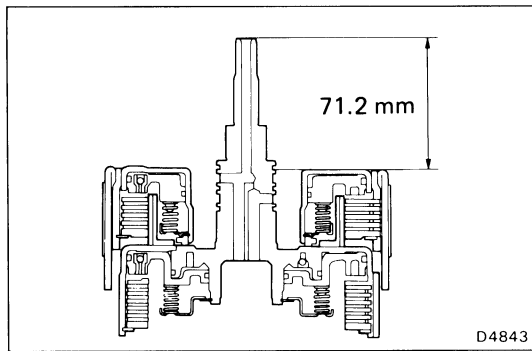

(d) Check that the distance from the direct clutch end to the forward clutch end is 71.2 mm (2.803 in.).

If the distance is less than the above value, parts may have been assembled incorrectly, check and reassemble again.

## Second Coast Brake COMPONENTS

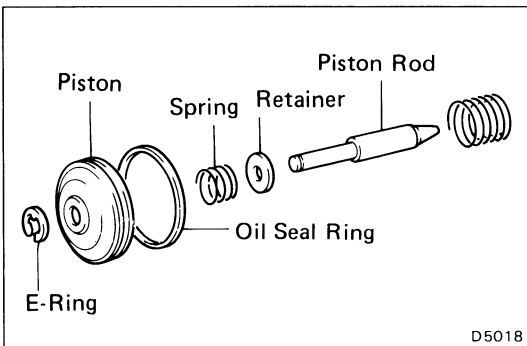
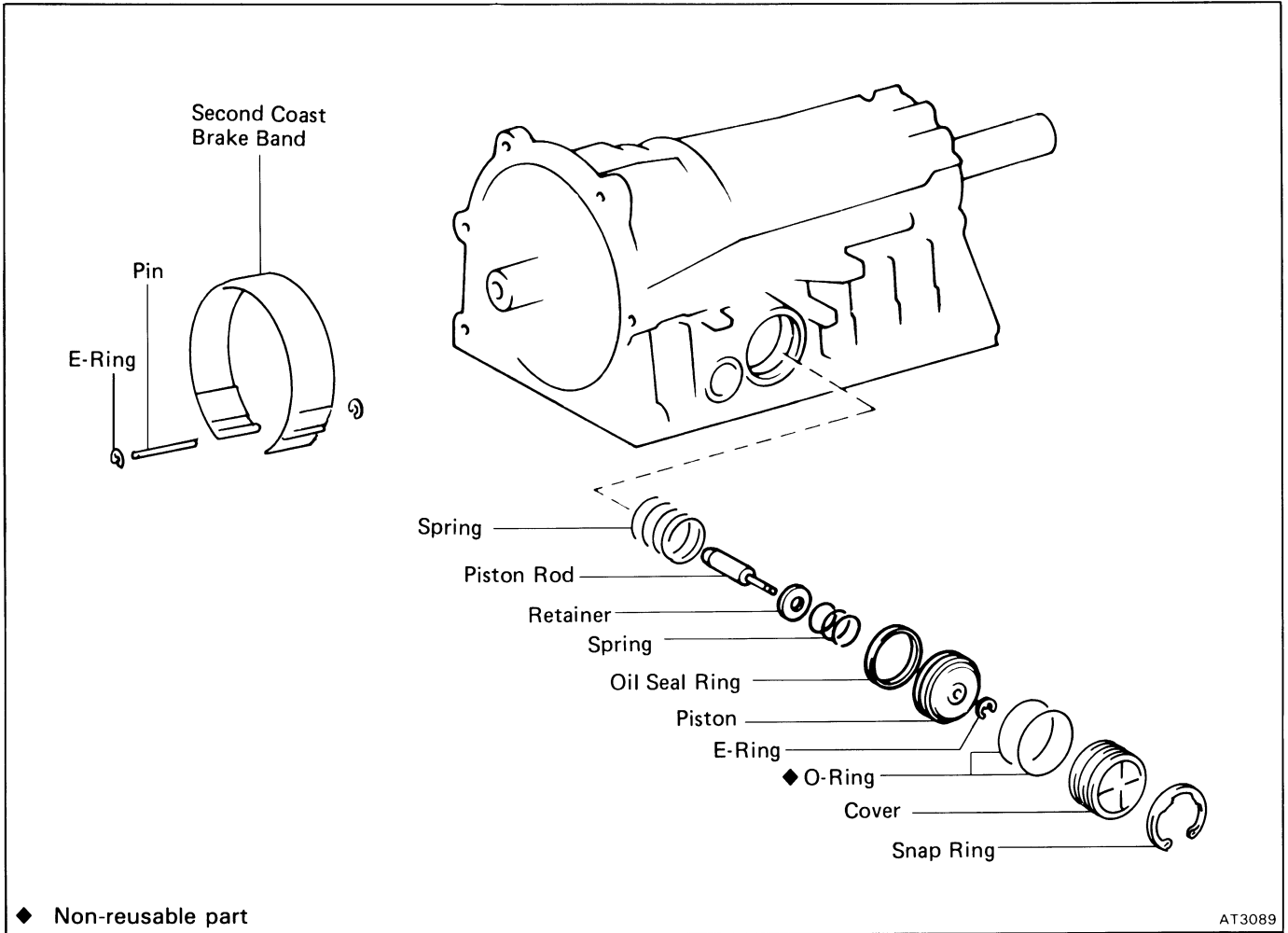

### DISASSEMBLY OF SECOND COAST BRAKE PISTON

#### DISASSEMBLE SECOND COAST BRAKE PISTON

- (a) Remove the E-ring.
- (b) Remove the piston, spring and retainer from the piston rod.
- (c) Remove the oil seal ring from the piston.

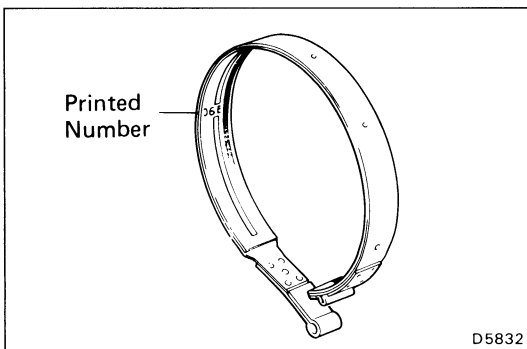

### INSPECTION OF SECOND COAST BRAKE BAND

#### INSPECT BRAKE BAND

If the lining of the brake band is peeling off or discolored, or even if parts of the printed numbers are defaced, replace the brake band.

**HINT:** Before assembling new band, soak it in ATF for at least two hours.

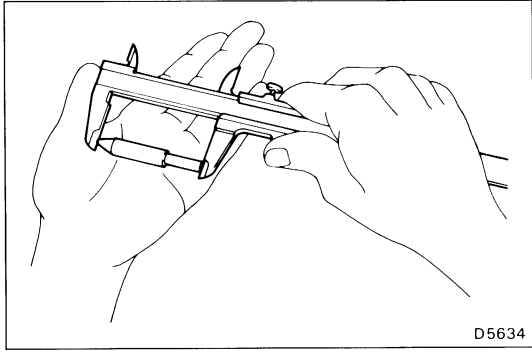

## ASSEMBLY OF SECOND COAST BRAKE PISTON

### 1. SELECT PISTON ROD

If the band is OK with piston rod stroke not within the standard value, select the piston rod.

There are two different lengths for piston rod.

**Piston rod length: 71.4 mm (2.811 in.)**  
**72.9 mm (2.870 in.)**

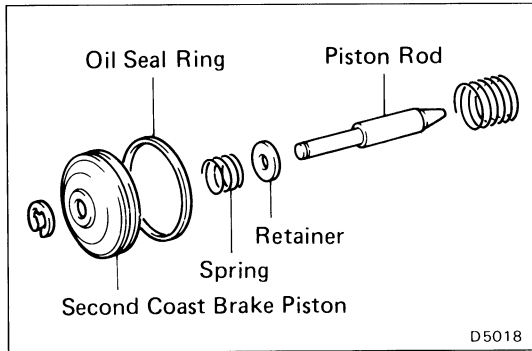

### 2. ASSEMBLE SECOND COAST BRAKE PISTON

- (a) Coat the oil seal ring with ATF and install it to the second coast brake piston.
- (b) Install the retainer, spring and piston to the piston rod.
- (c) Install the E-ring.

## Front Planetary Gear COMPONENTS

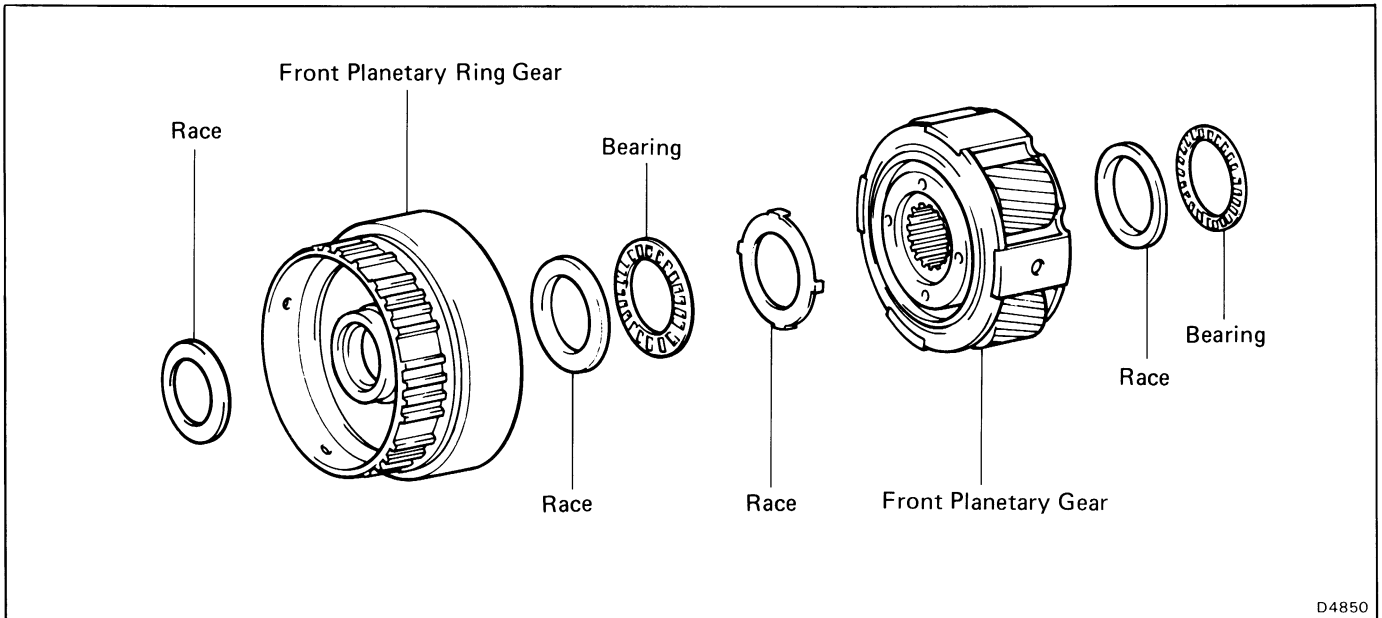

D4850

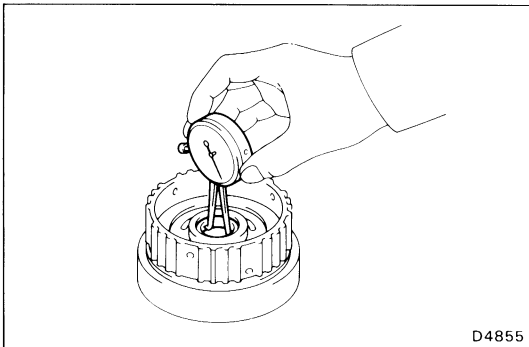

D4855

### INSPECTION OF FRONT PLANETARY GEAR

#### 1. CHECK FRONT PLANETARY RING GEAR BUSHING

Using a dial indicator, measure the inside diameter of the planetary ring gear bushing.

**Maximum inside diameter: 24.08 mm (0.9480 in.)**

If the inside diameter is greater than the maximum, replace the planetary ring gear.

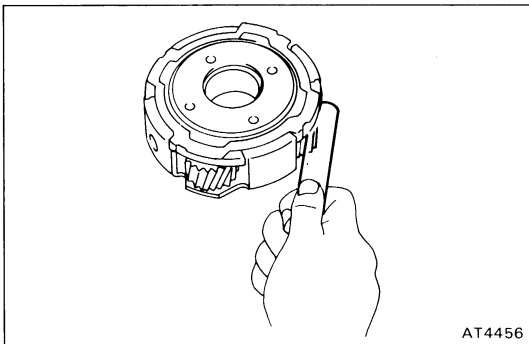

AT4456

#### 2. MEASURE PLANETARY PINION GEAR THRUST CLEARANCE

Using a feeler gauge, measure the planetary pinion gear thrust clearance.

**Standard clearance: 0.20 — 0.60 mm  
(0.0079 — 0.0236 in.)**

**Maximum clearance: 1.00 mm (0.0394 in.)**

If the clearance is greater than the maximum, replace the planetary gear assembly.

## Planetary Sun Gear and No. 1 One-Way Clutch COMPONENTS

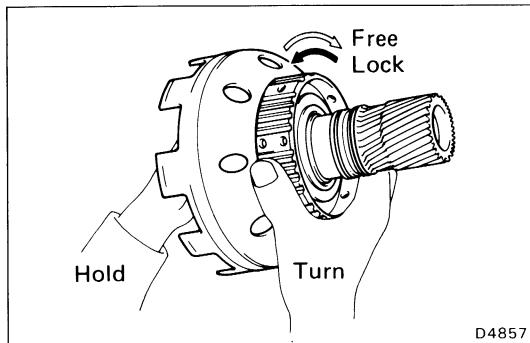
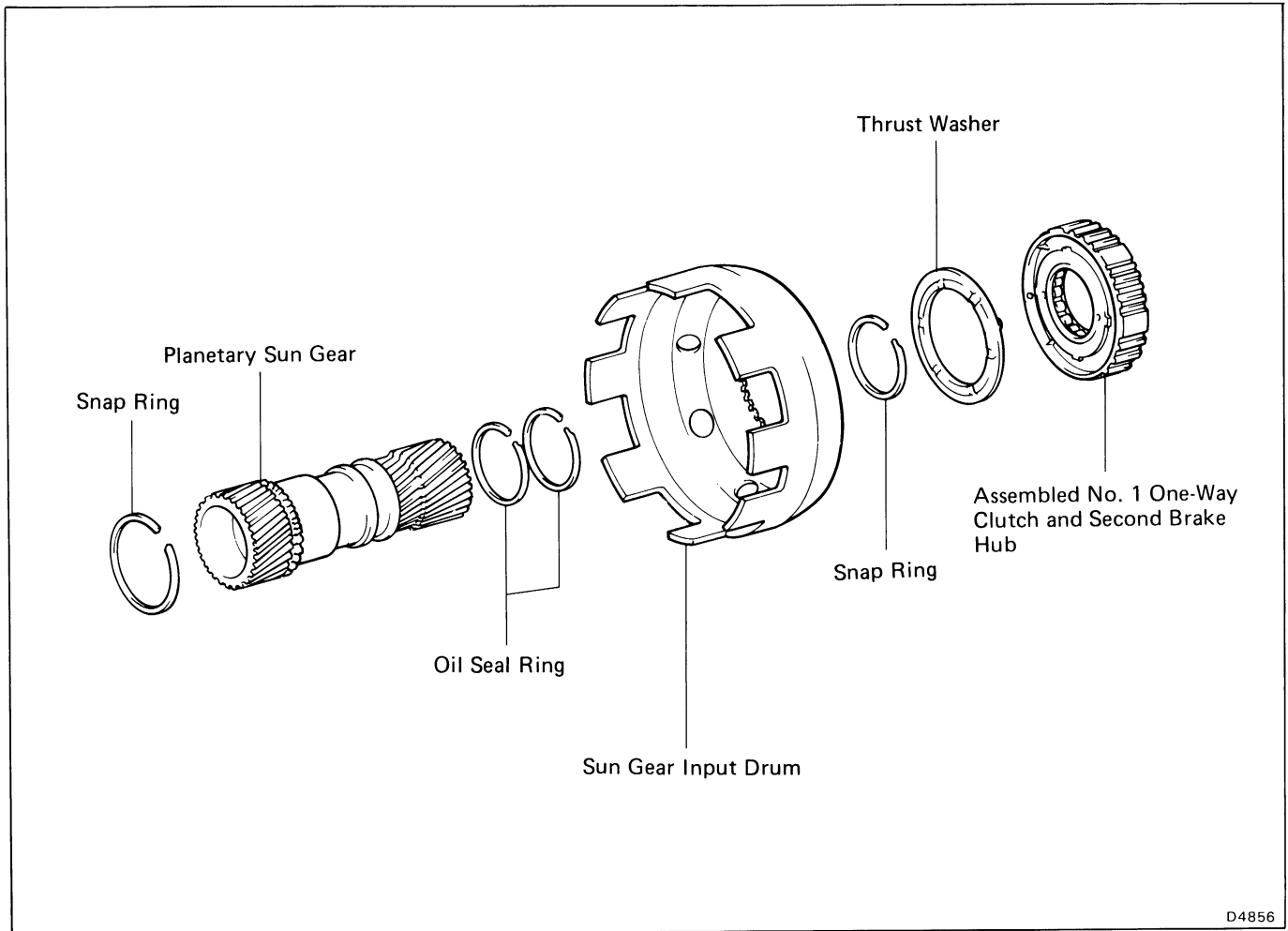

### DISASSEMBLY OF PLANETARY SUN GEAR AND NO. 1 ONE-WAY CLUTCH

#### 1. CHECK OPERATION OF NO. 1 ONE-WAY CLUTCH

Hold the planetary sun gear and turn the second brake hub. The second brake hub turns freely clockwise and locks counterclockwise.

#### 2. REMOVE ASSEMBLED NO. 1 ONE-WAY CLUTCH AND SECOND BRAKE HUB

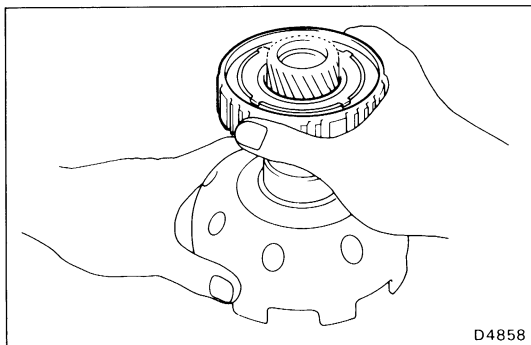



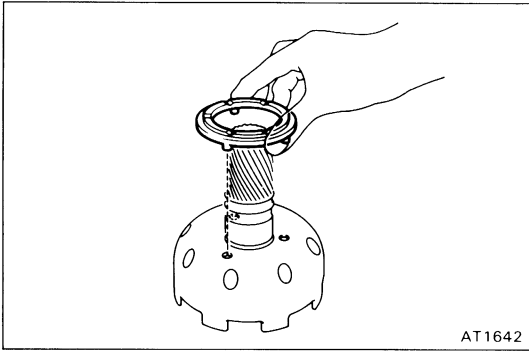

**3. REMOVE THRUST WASHER FROM SUN GEAR INPUT DRUM**

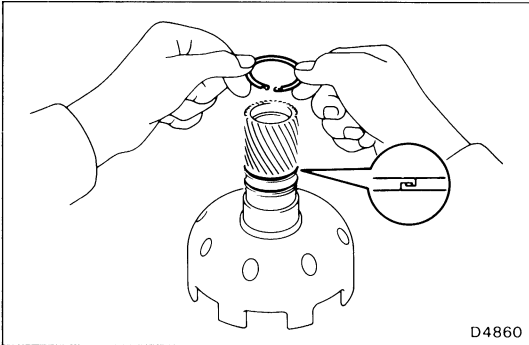

**4. REMOVE OIL SEAL RINGS**

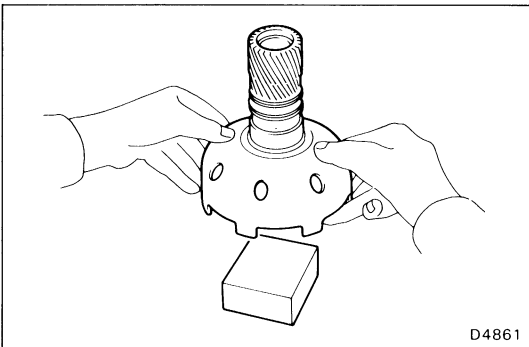

**5. REMOVE SUN GEAR INPUT DRUM FROM PLANETARY SUN GEAR**

(a) Use a wooden block, etc. as work stand.

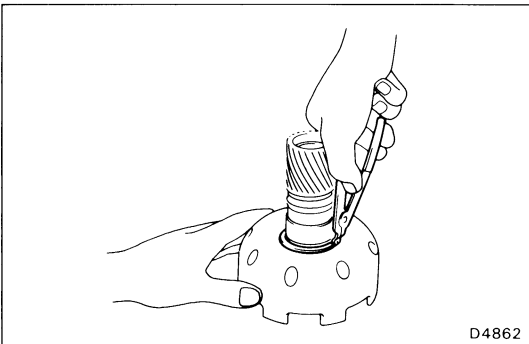

(b) Using snap ring pliers, remove the snap ring.

(c) Remove the sun gear input drum from the planetary sun gear.

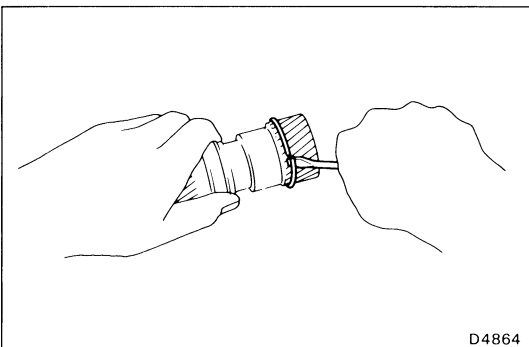

**6. REMOVE SNAP RING FROM PLANETARY SUN GEAR**

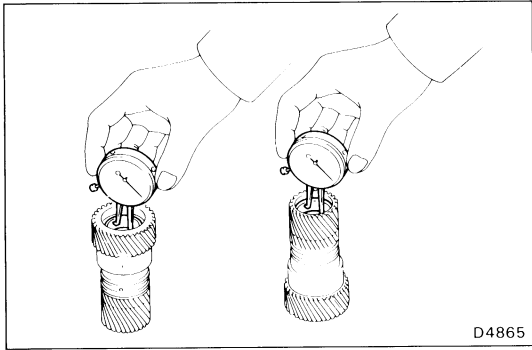

D4865

## INSPECTION OF PLANETARY SUN GEAR

### CHECK PLANETARY SUN GEAR BUSHINGS

Using a dial indicator, measure the inside diameter of the planetary sun gear bushings.

**Maximum inside diameter: 27.08 mm (1.0661 in.)**

If the inside diameter is greater than the maximum, replace the planetary sun gear.

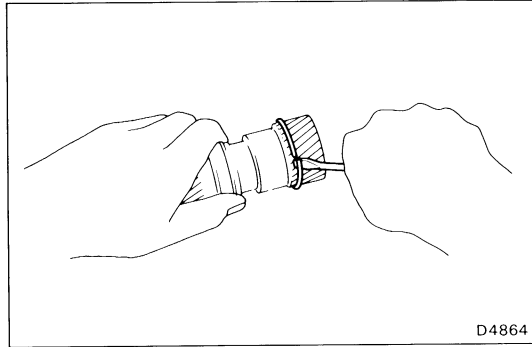

D4864

## ASSEMBLY OF PLANETARY SUN GEAR AND NO. 1 ONE-WAY CLUTCH

### 1. INSTALL SNAP RING TO PLANETARY SUN GEAR

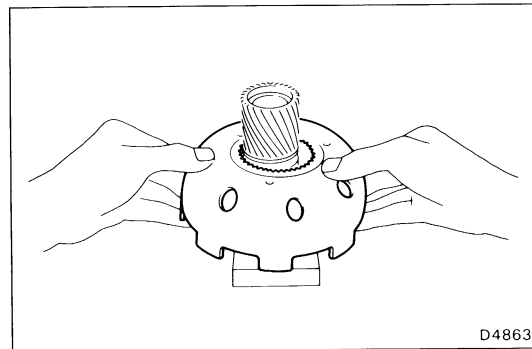

D4863

### 2. INSTALL SUN GEAR INPUT DRUM

- (a) Place a wooden block, etc. as a work stand and place the planetary sun gear onto it.
- (b) Install the sun gear input drum onto the planetary sun gear.

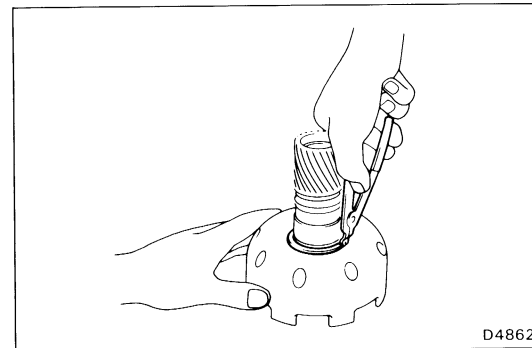

D4862

- (c) Install the snap ring with snap ring pliers.

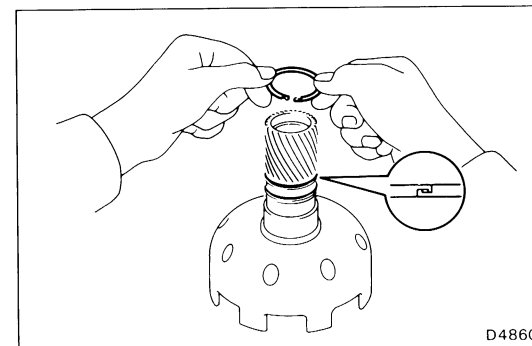

D4860

### 3. INSTALL OIL SEAL RINGS

- (a) Coat the two oil seal rings with ATF.
- (b) Install the two oil seal rings onto the planetary sun gear.

**NOTICE: Do not spread the ring ends too much.**

**HINT:** After installing the oil seal rings, check that they rotate smoothly.

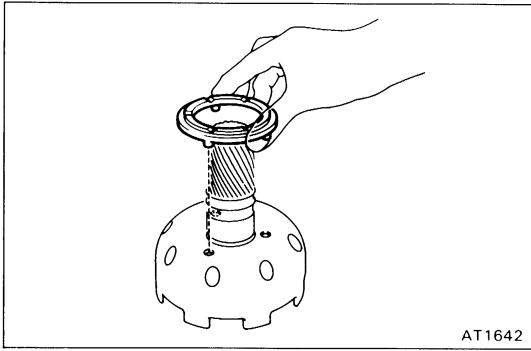

**4. INSTALL THRUST WASHER**

**HINT:** Make sure that the lug shapes match the holes on the sun gear input drum.

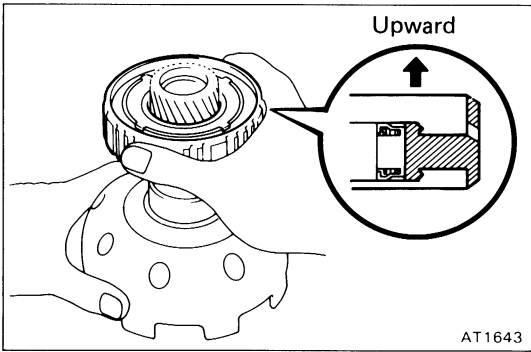

**5. INSTALL ASSEMBLED NO. 1 ONE-WAY CLUTCH AND SECOND BRAKE HUB ONTO PLANETARY SUN GEAR AS SHOWN**

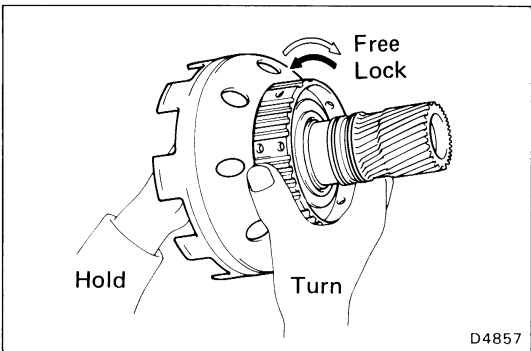

**6. CHECK OPERATION OF NO. 1 ONE-WAY CLUTCH**

Hold the planetary sun gear and turn the second brake hub. The second brake hub turns freely clockwise and locks counterclockwise.

## Second Brake COMPONENTS

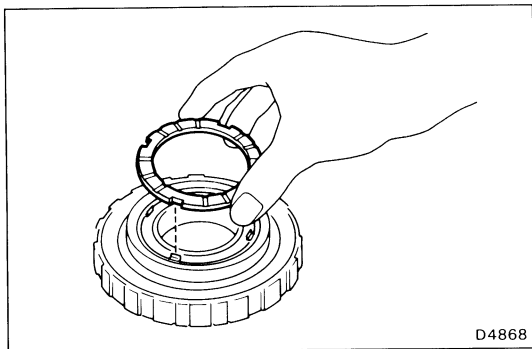
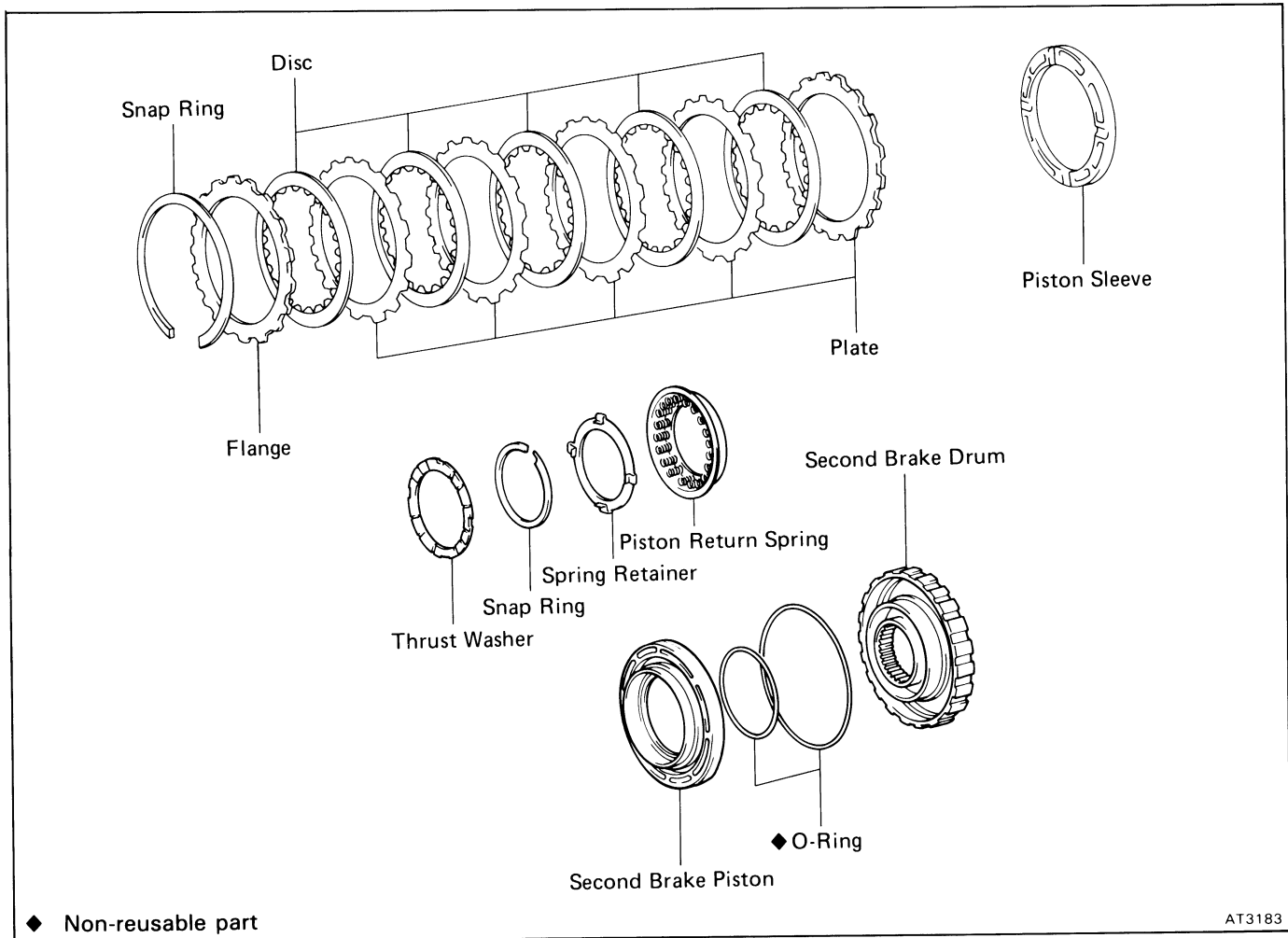

### DISASSEMBLY OF SECOND BRAKE

1. REMOVE THRUST WASHER FROM SECOND BRAKE DRUM

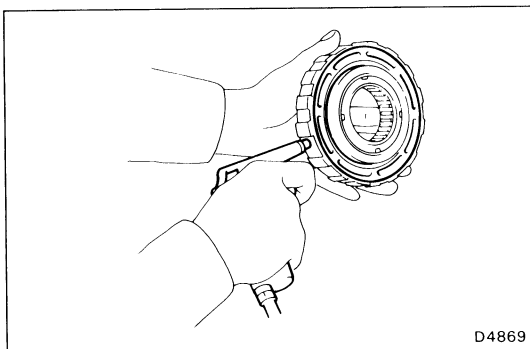

2. CHECK SECOND BRAKE PISTON MOVING

Make sure the second brake piston moves smoothly when applying and releasing low-pressure compressed air to the second brake drum.

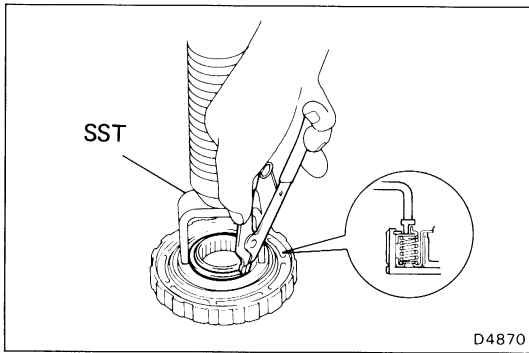

### 3. REMOVE PISTON RETURN SPRING

- (a) Place SST on the spring retainer, and compress the return spring with a shop press.

SST 09350-30020 (09350-07040)

- (b) Remove the snap ring with snap ring pliers.  
 (c) Remove the spring retainer.

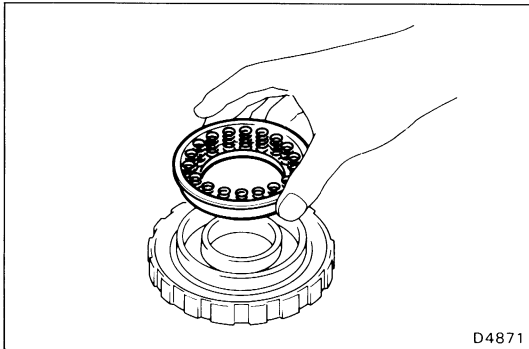

- (d) Remove the piston return spring.

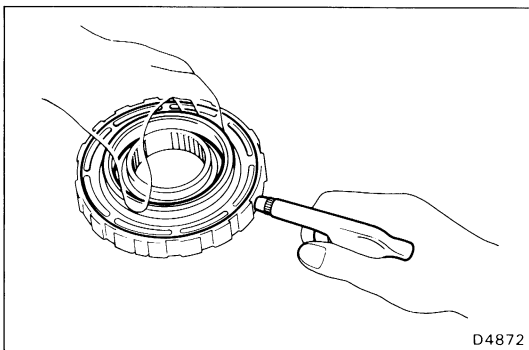

### 4. REMOVE SECOND BRAKE PISTON

- (a) Hold the second brake piston with hand, apply compressed air to the second brake drum to remove the second brake piston.  
 (b) Remove the second brake piston.  
 (c) Remove the two O-rings from the piston.

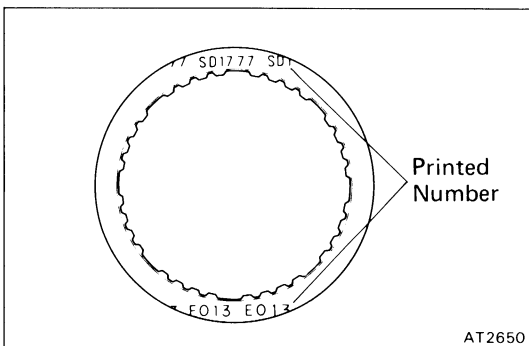

## INSPECTION OF SECOND BRAKE

### INSPECT DISC, PLATE AND FLANGE

Check to see if the sliding surface of the disc, plate and flange are worn or burnt. If necessary, replace them.

#### HINT:

- If the lining of the disc is peeling off or discolored, or even if parts of the printed numbers are defaced, replace all discs.
- Before assembling new discs, soak them in ATF for at least two hours.

## ASSEMBLY OF SECOND BRAKE

### 1. INSTALL SECOND BRAKE PISTON

- (a) Coat new O-rings with ATF and install them on the second brake piston.  
 (b) Being careful not to damage the O-rings, press in the second brake piston into the second brake drum with both hands.

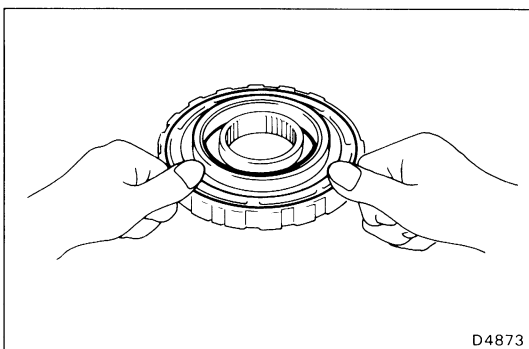

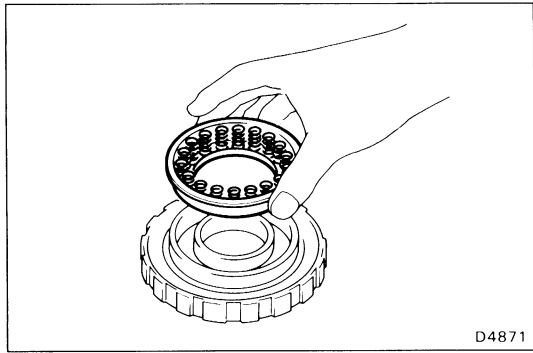

## 2. INSTALL PISTON RETURN SPRING

- (a) Install the piston return spring.
- (b) Install the spring retainer.

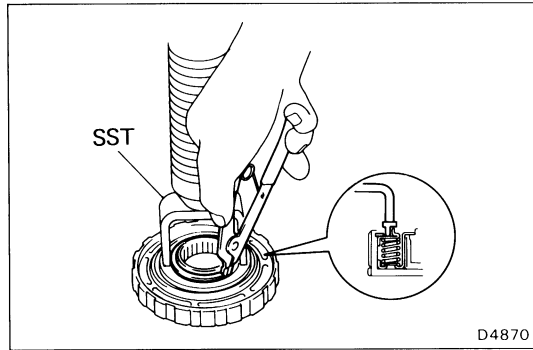

- (c) Place SST on the spring retainer, and compress the return spring with a shop press.

SST 09350-30020 (09350-07040)

- (d) Install the snap ring with snap ring pliers.

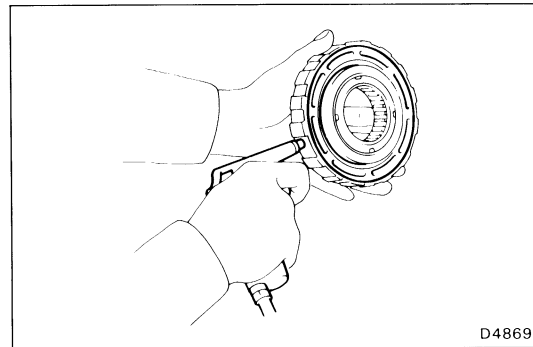

## 3. CHECK SECOND BRAKE PISTON MOVING

Make sure the second brake piston moves smoothly when applying and releasing low-pressure compressed air to the second brake drum.

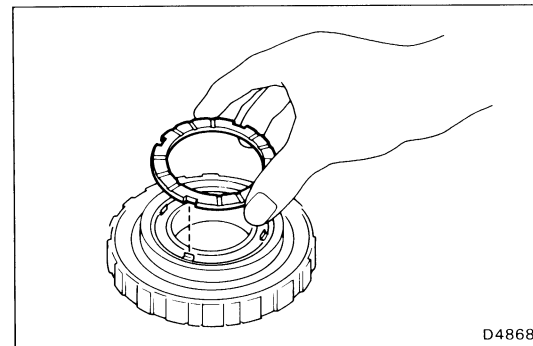

## 4. INSTALL THRUST WASHER

Coat the thrust washer with petroleum jelly and install it.

**HINT:** Make sure that the cutout portions of thrust washer match teeth of the spring retainer.

## First and Reverse Brake COMPONENTS

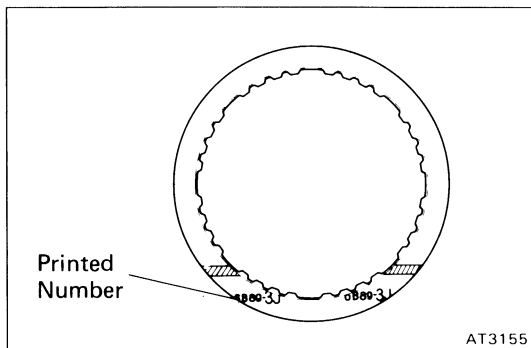
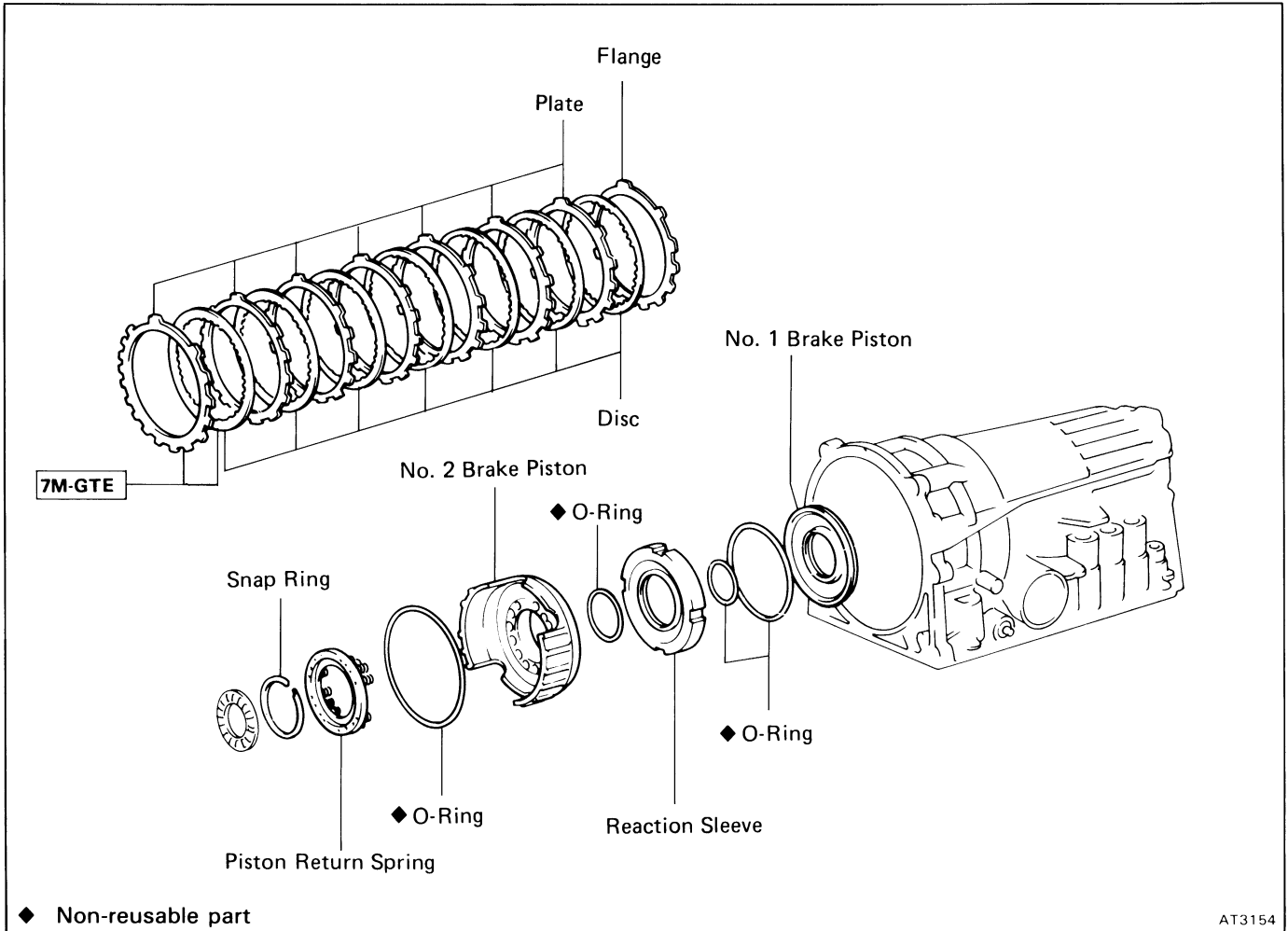

### INSPECTION OF FIRST AND REVERSE BRAKE

#### INSPECT DISC, PLATE AND FLANGE

Check to see if the sliding surface of the disc, plate and flange are worn or burnt. If necessary, replace them.

#### HINT:

- If the lining of the disc is peeling off or discolored, or even if parts of the printed numbers are defaced, replace all discs.
- Before assembling new discs, soak them in ATF for at least two hours.

# Rear Planetary Gear, No. 2 One-Way Clutch and Output Shaft COMPONENTS

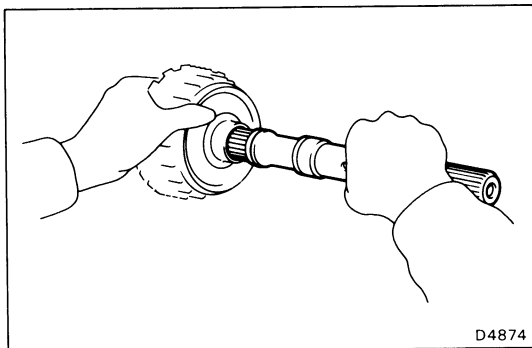
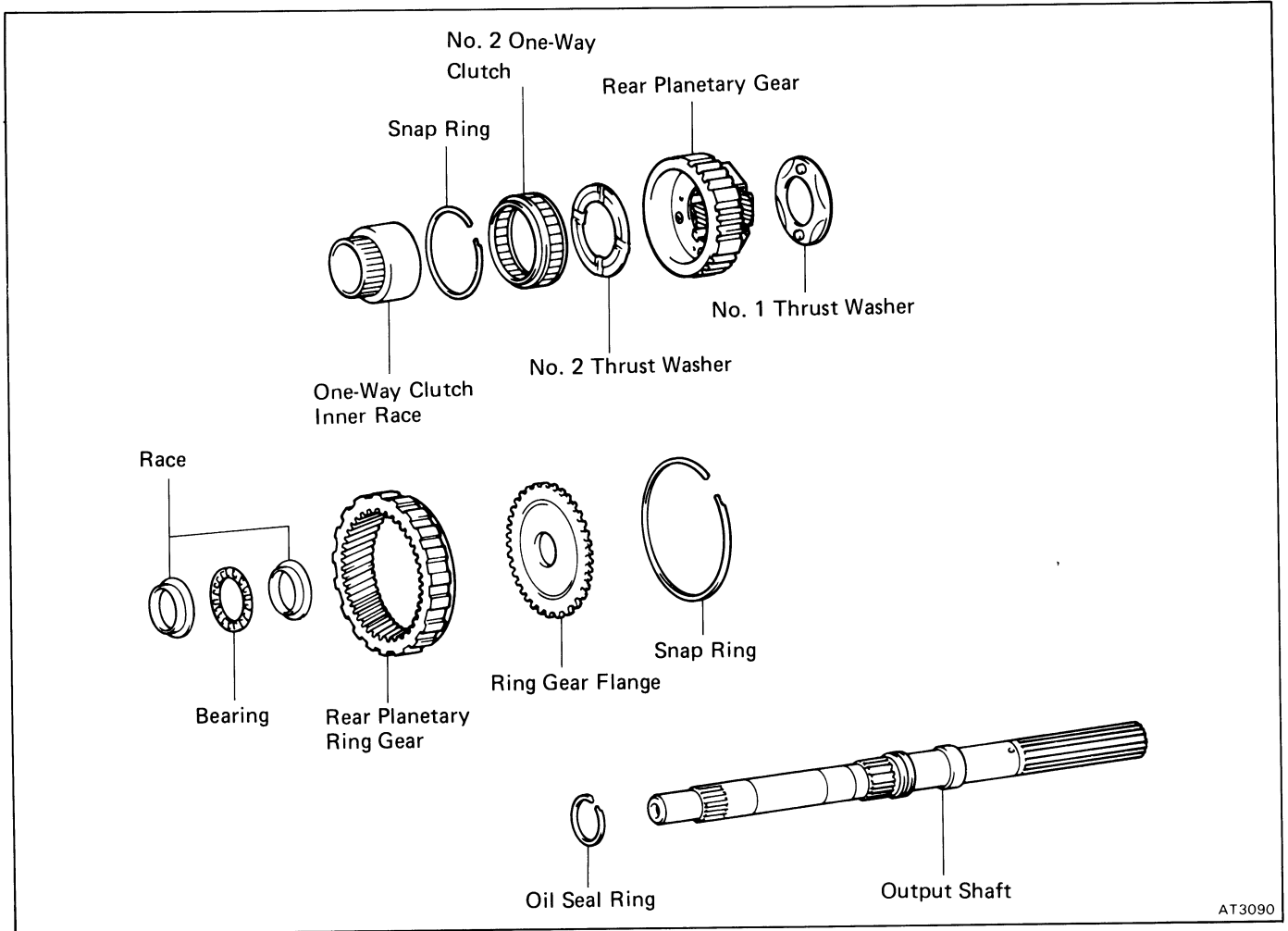

## DISASSEMBLY OF REAR PLANETARY GEAR, NO. 2 ONE-WAY CLUTCH AND OUTPUT SHAFT

1. REMOVE OUTPUT SHAFT FROM REAR PLANETARY GEAR ASSEMBLY

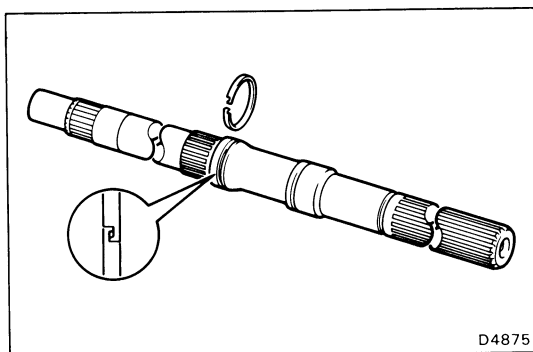

2. REMOVE OIL SEAL RING FROM OUTPUT SHAFT

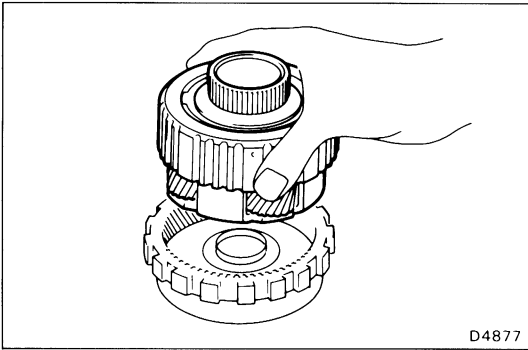
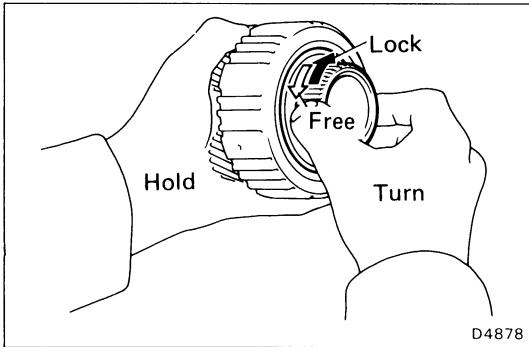

**3. REMOVE REAR PLANETARY GEAR FROM REAR PLANETARY RING GEAR****4. CHECK OPERATION OF NO. 2 ONE-WAY CLUTCH**

Hold the planetary gear and turn the one-way clutch inner race. The one-way clutch inner race turns freely counter-clockwise and locks clockwise.

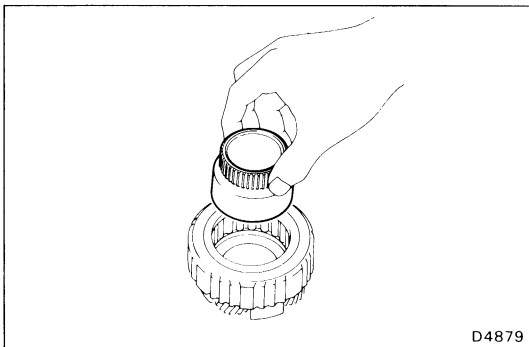
**5. REMOVE NO. 2 ONE-WAY CLUTCH**

(a) Remove the one-way clutch inner race from the rear planetary gear.

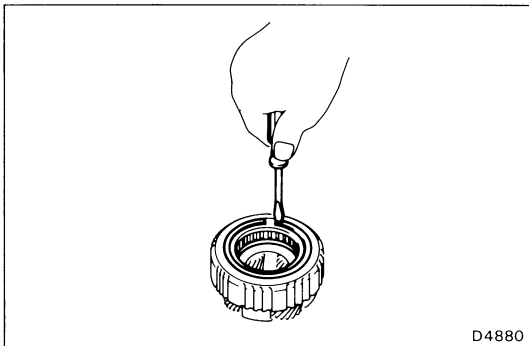

(b) Remove the snap ring with a screwdriver.

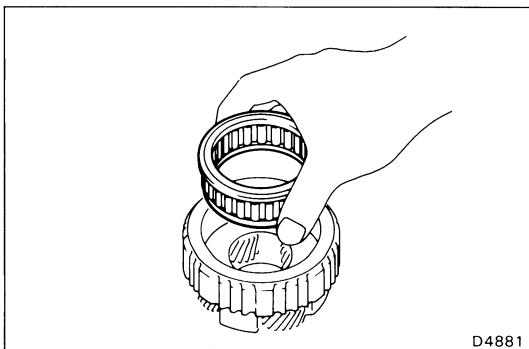

(c) Remove No. 2 one-way clutch with retainers from the planetary gear.

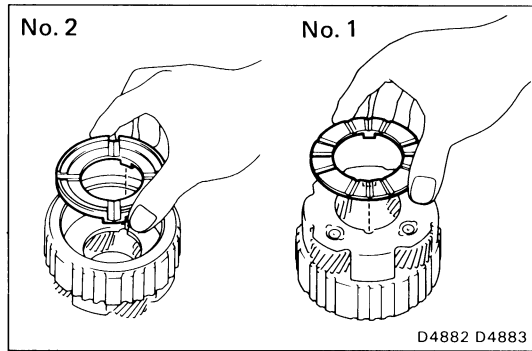

## 6. REMOVE NO. 2 AND NO. 1 THRUST WASHERS

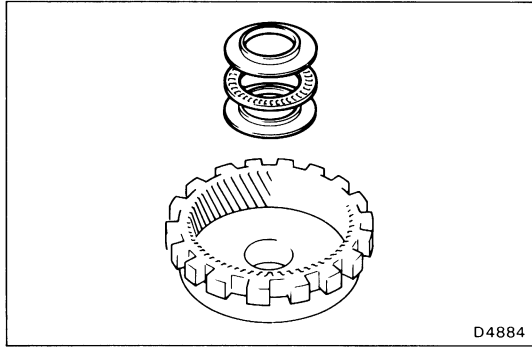

## 7. REMOVE RACES AND BEARING FROM REAR PLANETARY RING GEAR

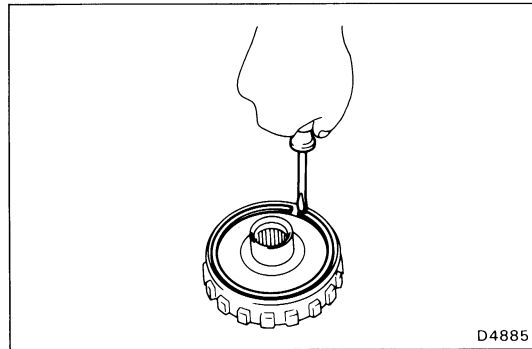

## 8. REMOVE RING GEAR FLANGE

(a) Remove the snap ring with a screwdriver.

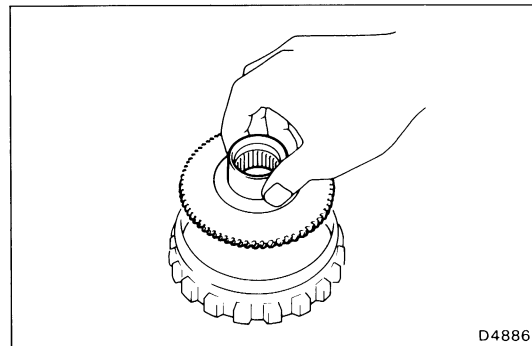

(b) Remove the ring gear flange.

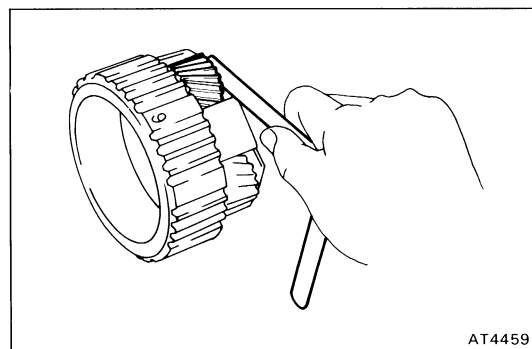

## INSPECTION OF REAR PLANETARY GEAR

### MEASURE PLANETARY PINION GEAR THRUST CLEARANCE

Using a feeler gauge, measure the planetary pinion gear thrust clearance.

**Standard clearance:** 0.20 — 0.60 mm  
(0.0079 — 0.0236 in.)

**Maximum clearance:** 1.00 mm (0.0394 in.)

If the clearance is greater than the maximum, replace the planetary gear assembly.

## ASSEMBLY OF REAR PLANETARY GEAR, NO. 2 ONE-WAY CLUTCH AND OUTPUT SHAFT

### 1. INSTALL RING GEAR FLANGE

- (a) Install the ring gear flange.
- (b) Install the snap ring.

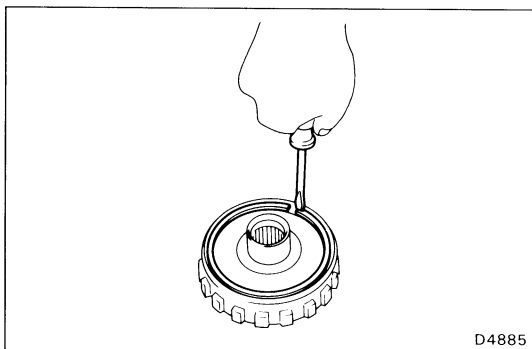

D4885

### 2. INSTALL RACES AND BEARING

Coat the races and bearing with petroleum jelly, and install them onto the rear planetary ring gear.

HINT: Races and bearing diameter

mm (in.)

	Inside	Outside
Race (A)	28.8 (1.134)	44.8 (1.764)
Bearing	30.1 (1.185)	44.7 (1.760)
Race (B)	27.8 (1.094)	44.8 (1.764)

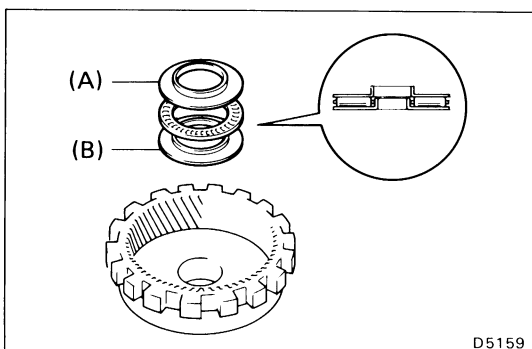

D5159

### 3. INSTALL NO. 1 AND NO. 2 THRUST WASHERS

- (a) Coat the thrust washers with petroleum jelly.
- (b) Install the thrust washers onto both sides of the rear planetary gear.

HINT: Make sure that the lug shapes match the cutout portions on the rear planetary gear.

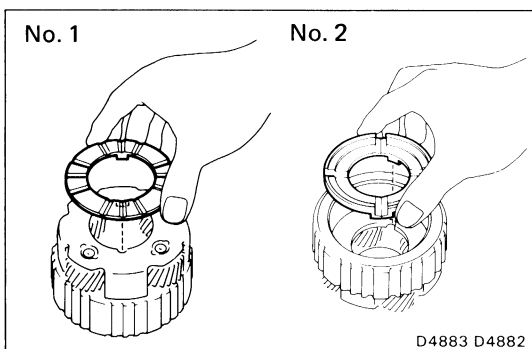

D4883 D4882

### 4. INSTALL NO. 2 ONE-WAY CLUTCH

- (a) Install the one-way clutch and two retainers into the rear planetary gear as shown in the figure.

HINT: Make sure that the open ends of the guides on the one-way clutch are faced upward.

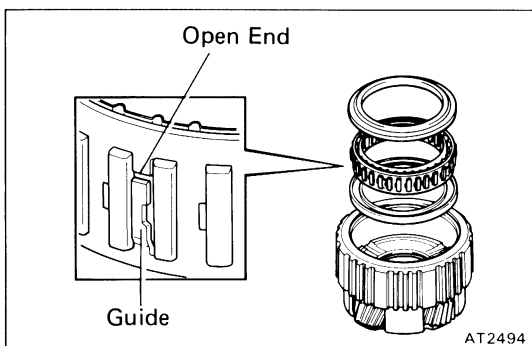

AT2494

- (b) Install the snap ring.

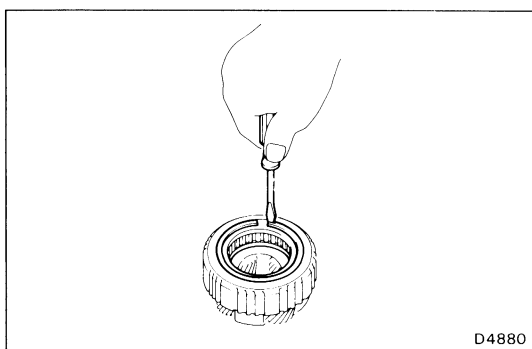

D4880

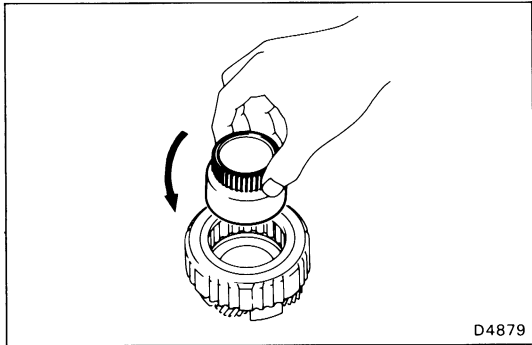

- (c) While turning counterclockwise, install the one-way clutch inner race to the rear planetary gear.

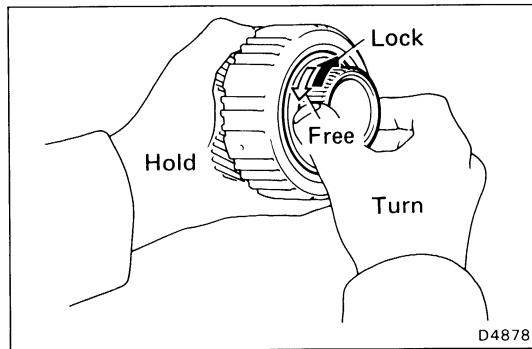

#### 5. CHECK OPERATION OF NO. 2 ONE-WAY CLUTCH

Hold the planetary gear and turn the one-way clutch inner race. The one-way clutch inner race turns freely counterclockwise and locks clockwise.

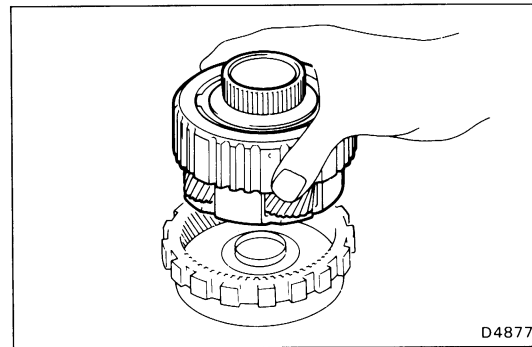

#### 6. INSTALL REAR PLANETARY GEAR ONTO REAR PLANETARY RING GEAR

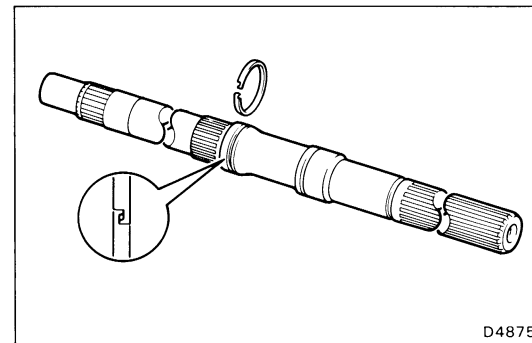

#### 7. INSTALL OIL SEAL RING

Coat the oil seal ring with ATF and install it to the output shaft.

**NOTICE:** Do not spread the ring ends too much.

**HINT:** After installing the oil seal ring, check that it rotates smoothly.

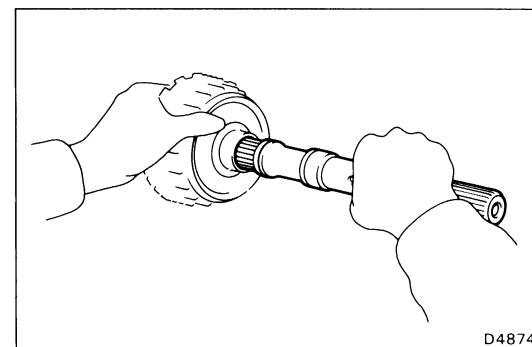

#### 8. INSTALL OUTPUT SHAFT INTO REAR PLANETARY GEAR ASSEMBLY

# Valve Body COMPONENTS

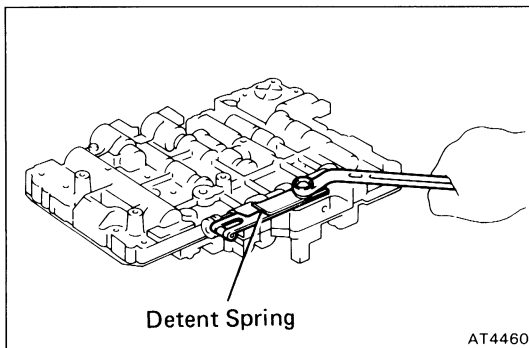
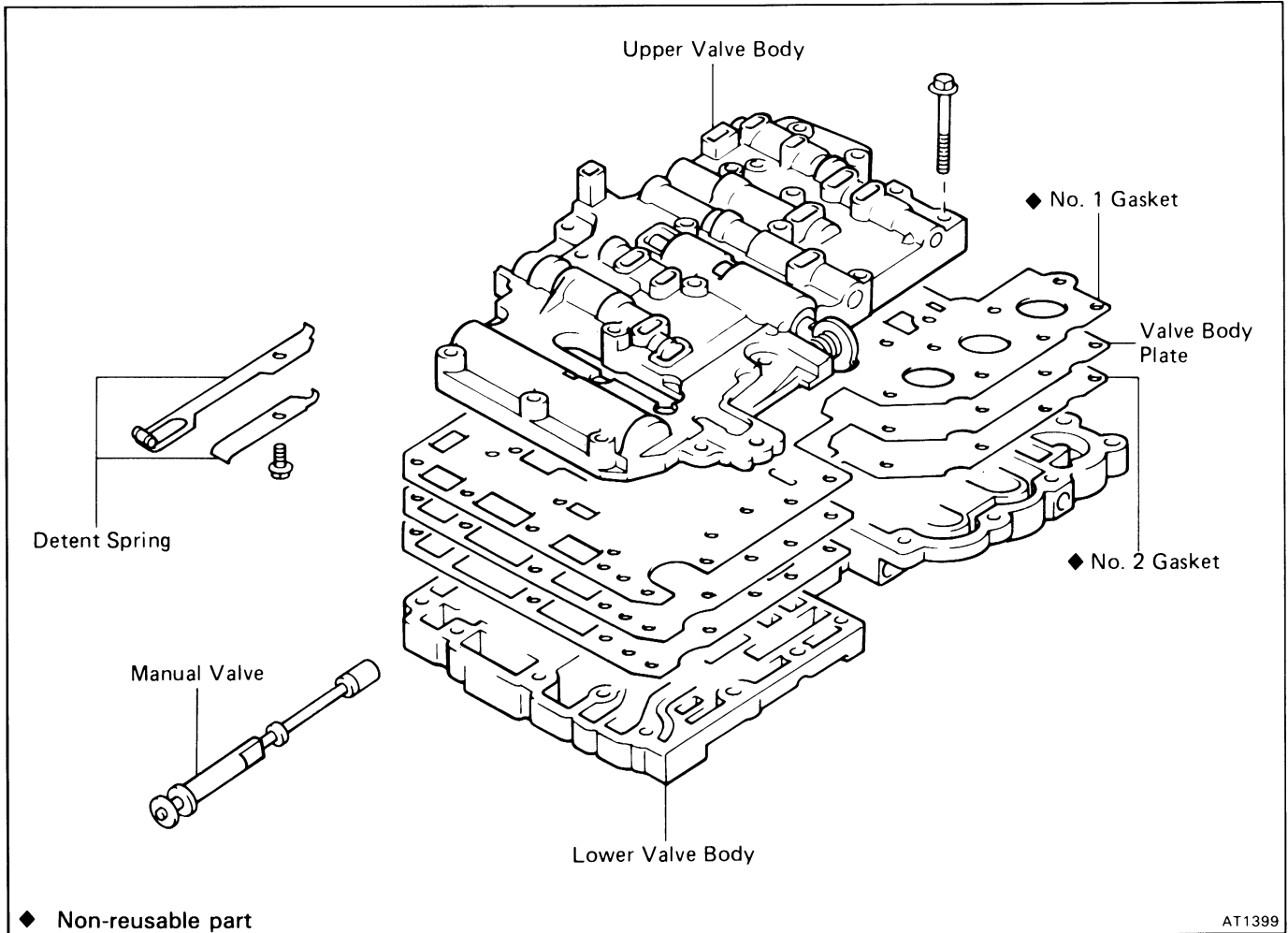

## (Disassembly of Valve Body)

1. UNBOLT AND REMOVE DETENT SPRING

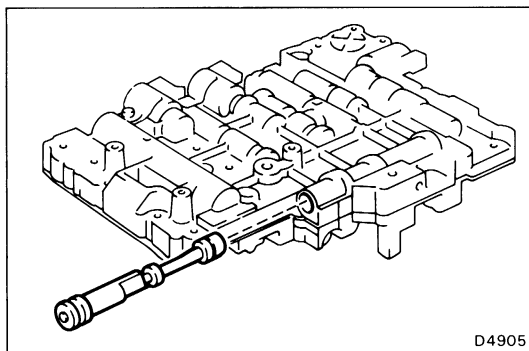

2. REMOVE MANUAL VALVE

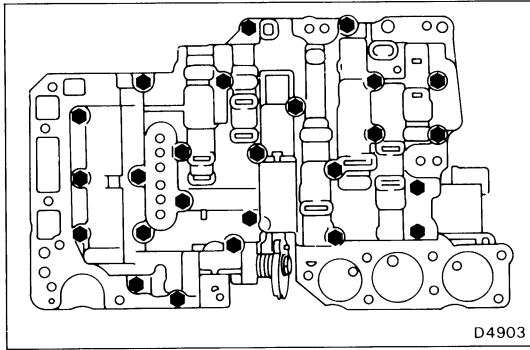

3. **TURN OVER ASSEMBLY AND REMOVE TWENTY-FIVE BOLTS**

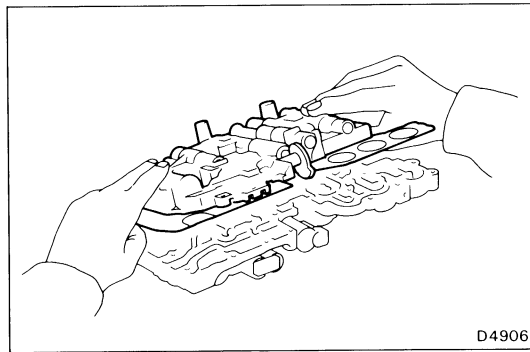

4. **LIFT OFF UPPER VALVE BODY AND PLATE AS A SINGLE UNIT**

Hold the valve body plate to the upper valve body.

**HINT:** Be careful that the check balls and strainer do not fall out.

# (Upper Valve Body) COMPONENTS

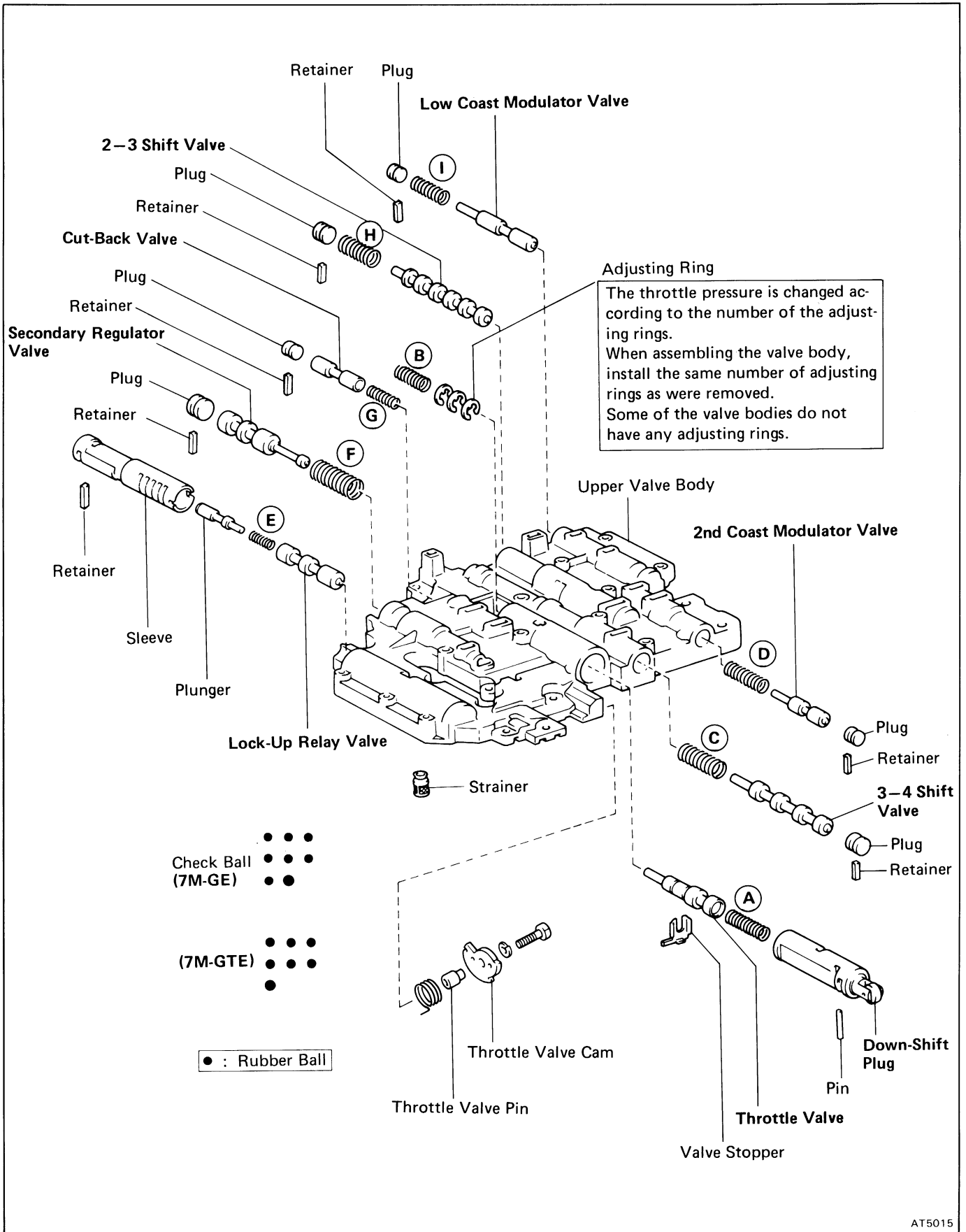

**SPECIFICATIONS OF VALVE BODY SPRINGS**

Spring	Free length mm (in.)	Coil outer diameter mm (in.)	Total No. of coils	Color
(A) Down-shift plug	27.3 (1.075)	8.7 (0.343)	12.5	Yellow
(B) Throttle valve	20.6 (0.811) or 23.3 (0.917)	9.2 (0.362) 9.2 (0.362)	9.5 9.5	Blue White
(C) 3 – 4 shift valve	30.8 (1.213)	9.7 (0.382)	10.5	Purple
(D) Second coast modulator valve	7M-GE 25.3 (0.996) 7M-GTE 29.6 (1.165)	8.6 (0.339) 8.3 (0.327)	11.5 12.5	Orange Red
(E) Lock-up relay valve	21.4 (0.843)	5.5 (0.217)	17.5	Light Gray
(F) Secondary regulator valve	30.9 (1.217)	11.2 (0.441)	10.5	Blue
(G) Cut-back valve	21.8 (0.858)	6.0 (0.236)	13.5	None
(H) 2 – 3 shift valve	30.8 (1.213)	9.7 (0.382)	10.5	Purple
(I) Low coast modulator valve	27.8 (1.094)	8.3 (0.327)	10.5	Pink

**HINT:** During reassembly, please refer to the spring specifications above to help differentiate the different springs.

**SECTIONAL VIEW OF VALVE BODY**

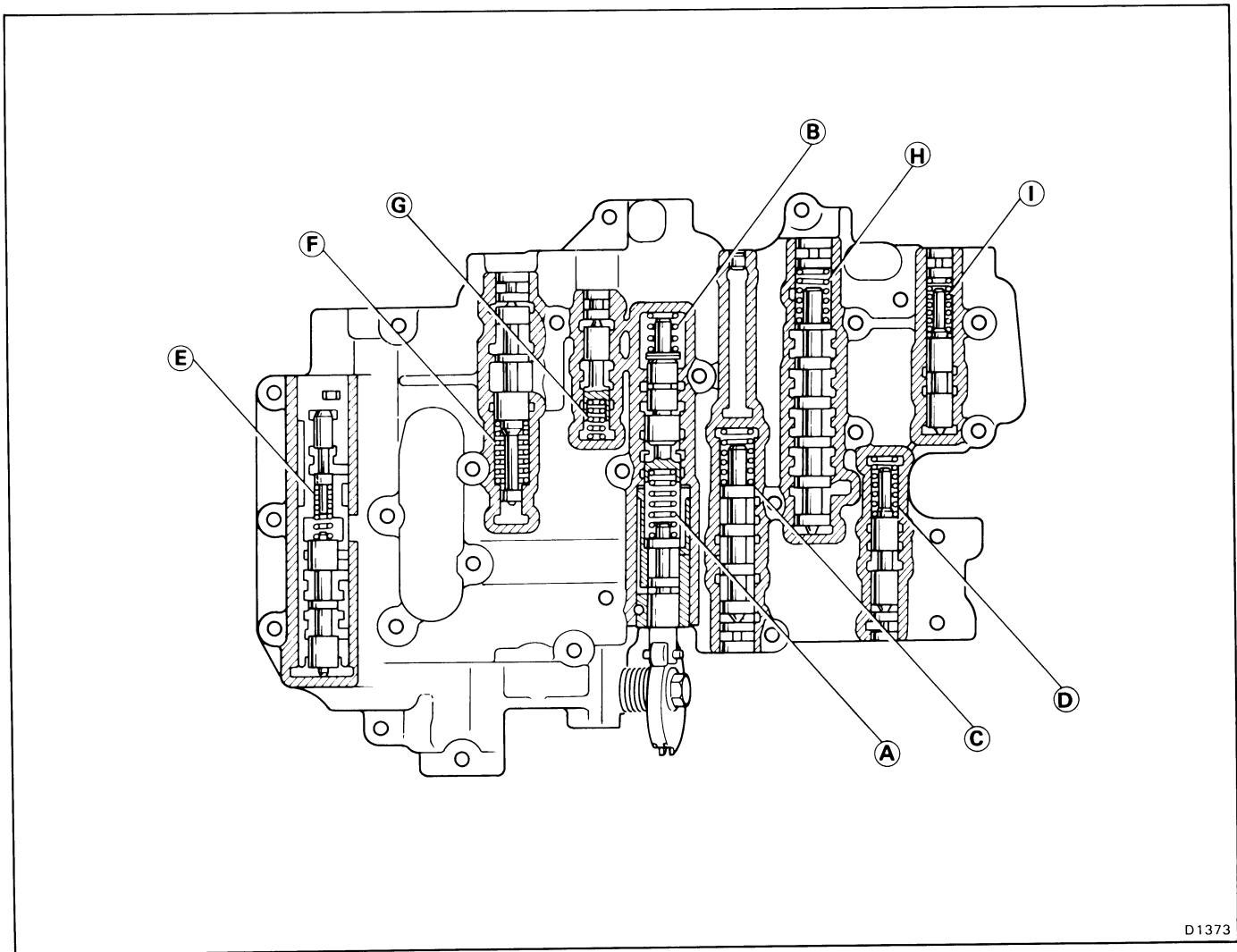



### LOCATION OF RETAINERS, PIN, STOPPER, CHECK BALLS AND STRAINER

#### 1. RETAINER, STOPPER AND PIN

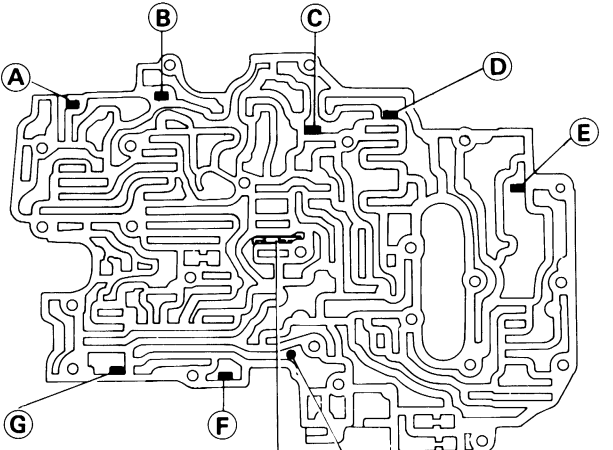

Diagram showing the locations of retainers, stoppers, and pins in the valve body. Labels A through G indicate specific components. A 'Valve Stopper' and 'Pin' are also labeled at the bottom of the diagram.

		mm (in.)		
Retainer	Height	Width	Thickness	
(A) Low coast modulator valve	14.5 (0.571)	5.0 (0.197)	3.2 (0.126)	
(B) 2-3 shift valve	14.0 (0.551)	5.0 (0.197)	3.2 (0.126)	
(C) Cut-back valve	15.0 (0.591)	5.0 (0.197)	3.2 (0.126)	
(D) Secondary regulator valve	14.0 (0.551)	5.0 (0.197)	3.2 (0.126)	
(E) Lock-up relay valve	21.2 (0.835)	5.0 (0.197)	3.2 (0.126)	
(F) 3-4 shift valve	16.5 (0.650)	6.0 (0.236)	3.2 (0.126)	
(G) 2nd coast modulator valve	16.5 (0.650)	6.0 (0.236)	3.2 (0.126)	

D4912

#### 2. CHECK BALL

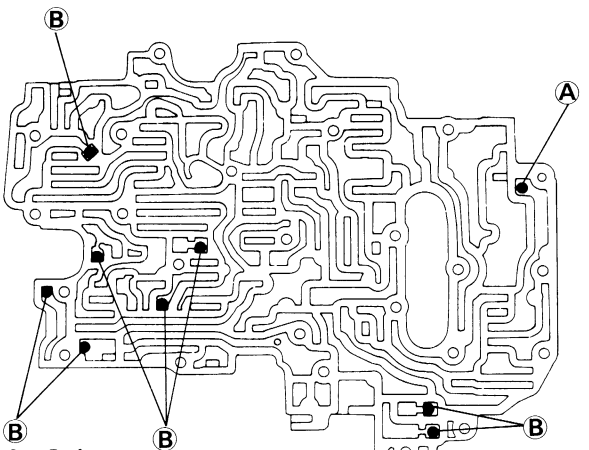

Diagram showing the locations of check balls in the valve body. Labels A and B indicate specific components. A note '7M-GE Only' is present near label B.

Check ball	Diameter	mm (in.)
(A) Rubber ball	6.35	(0.2500)
(B) Rubber ball	5.54	(0.2181)

AT5651

#### 3. STRAINER

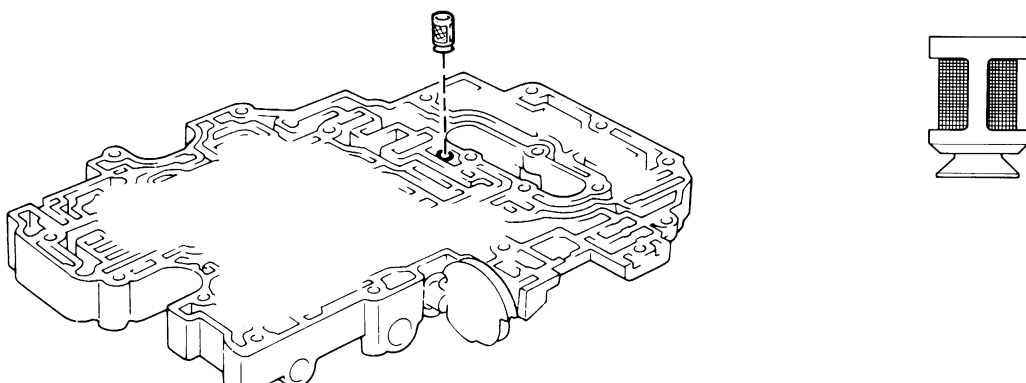
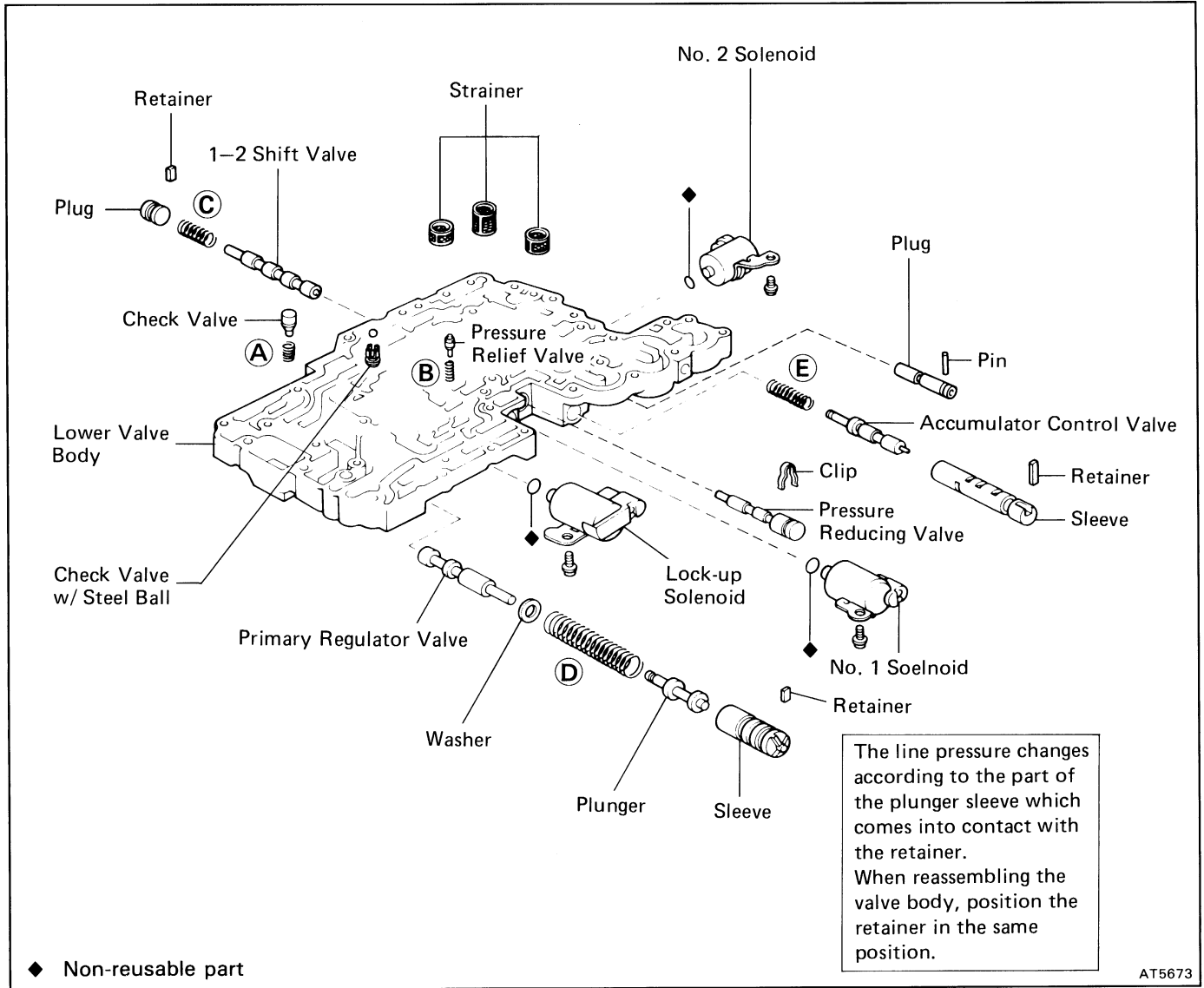

Diagram showing the location of the strainer in the valve body. A detailed view of the strainer component is shown to the right.

AT3243 AT4462

# (Lower Valve Body) COMPONENTS



**SPECIFICATIONS OF VALVE BODY SPRINGS**

Spring		Free length mm (in.)	Coil outer diameter mm (in.)	Total No. of coils	Color
(A)	Check valve	20.2 (0.795)	12.1 (0.476)	6.5	None
(B)	Pressure relief valve	11.2 (0.441)	6.4 (0.252)	7.5	None
(C)	1–2 shift valve	30.8 (1.213)	9.7 (0.382)	10.5	Purple
(D)	Primary regulator valve	66.7 (2.626)	18.6 (0.732)	12.5	None
(E)	Accumulator control valve	33.9 (1.335)	8.8 (0.346)	12.0	Pink

HINT: During reassembly, please refer to the spring specifications above to help differentiate the different springs.

**SECTIONAL VIEW OF VALVE BODY**

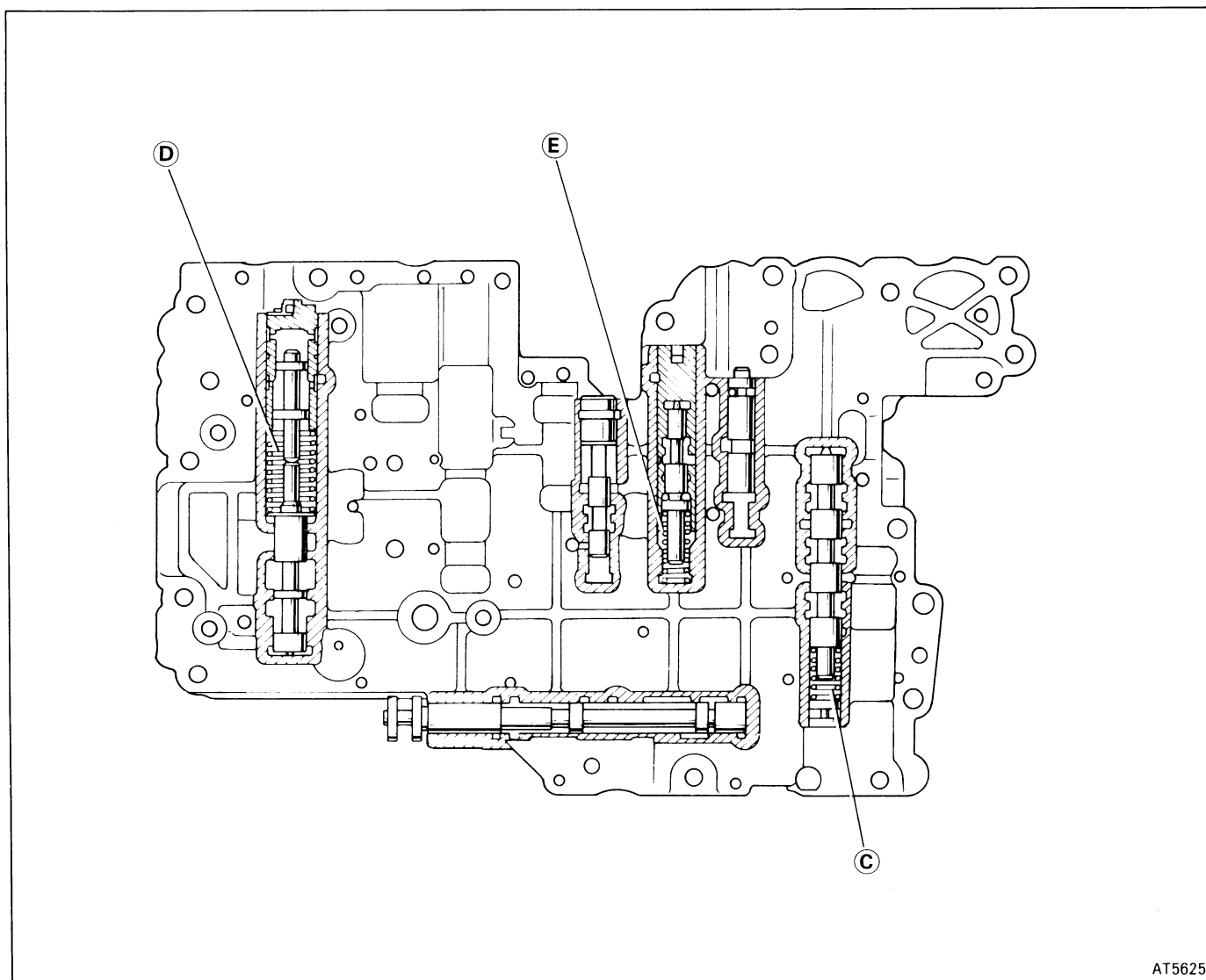

# LOCATION OF RETAINERS, CLIP, PIN, CHECK BALLS, STRAINERS, SPRINGS AND VALVES

## 1. RETAINER, CLIP AND PIN

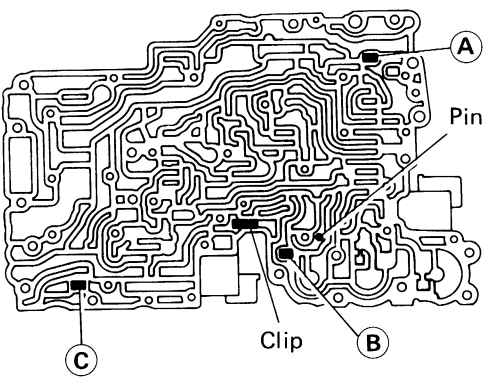

mm (in.)

	Retainer	Height	Width	Thickness
(A)	1-2 shift valve	16.5 (0.650)	6.0 (0.236)	3.2 (0.126)
(B)	Accumulator control valve	21.2 (0.835)	5.0 (0.197)	3.2 (0.126)
(C)	Primary regulator valve	16.2 (0.638)	5.0 (0.197)	3.2 (0.126)

AT5626

## 2. CHECK BALL

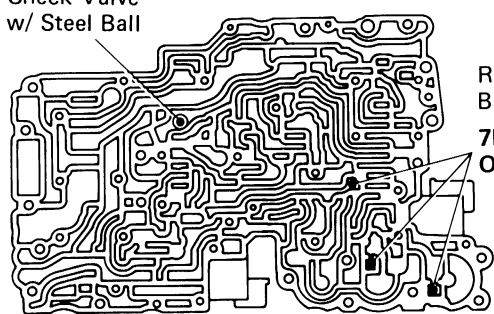

Check Valve w/ Steel Ball

Rubber Ball  
7M-GTE Only

	Check ball	Diameter	mm (in.)
	Rubber ball	5.54	(0.2181)
	Steel ball	6.35	(0.2500)

AT2346

## 3. STRAINER, SPRING AND VALVE

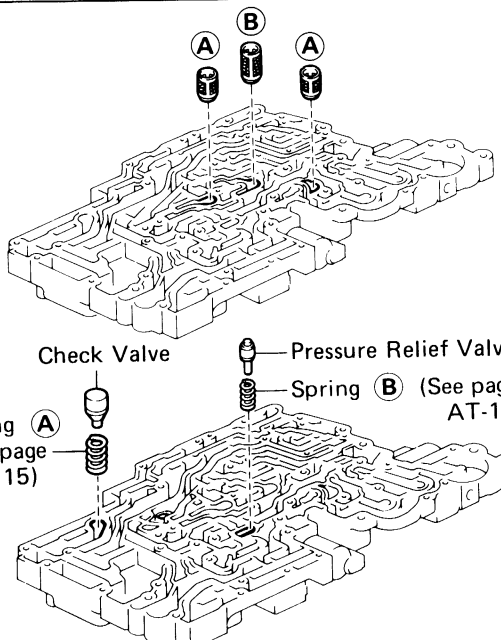

(A) (B) (A)

(A) (B)

mm (in.)

	Strainer	Height	Diameter
(A)	Solenoid oil strainer	11.0 (0.433)	10.3 (0.406)
(B)	Throttle oil strainer	19.5 (0.768)	10.3 (0.406)

Check Valve

Pressure Relief Valve

Spring (A) (See page AT-115)

Spring (B) (See page AT-115)

D4908

D4914

AT3296

## (Assembly of Valve Body)

(See page AT-109)

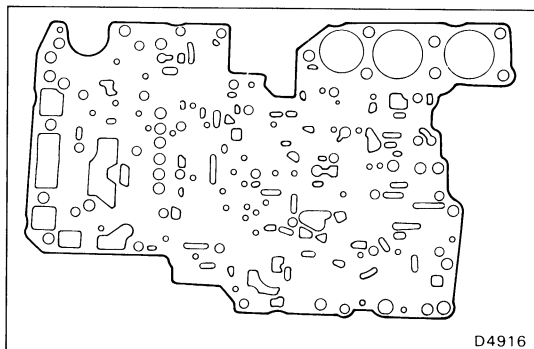

1. **POSITION NEW NO. 1 GASKET ON UPPER VALVE BODY**  
Align a new No. 1 gasket at each bolt hole.
2. **POSITION VALVE BODY PLATE ON NO. 1 GASKET**  
Align the plate at each bolt hole.

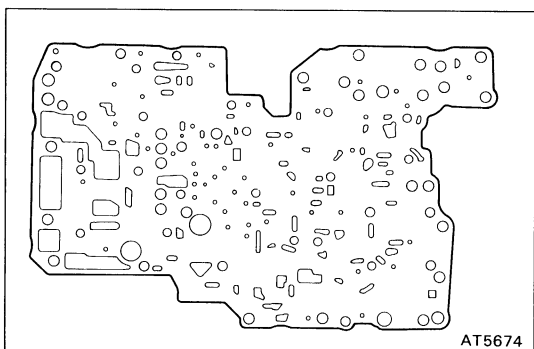

3. **POSITION NEW NO. 2 GASKET ON PLATE**  
Align a new No. 2 gasket at each bolt hole.

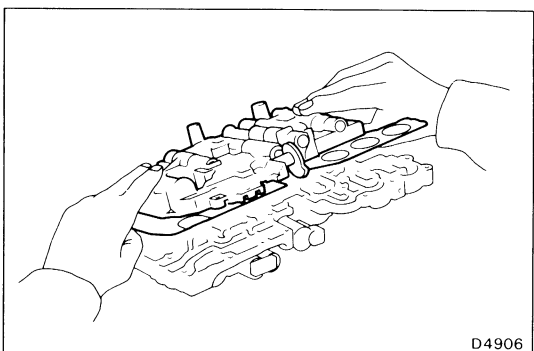

4. **PLACE UPPER VALVE BODY WITH PLATE AND GASKETS ON TOP OF LOWER VALVE BODY**  
Align each bolt hole and gasket in the valve body.

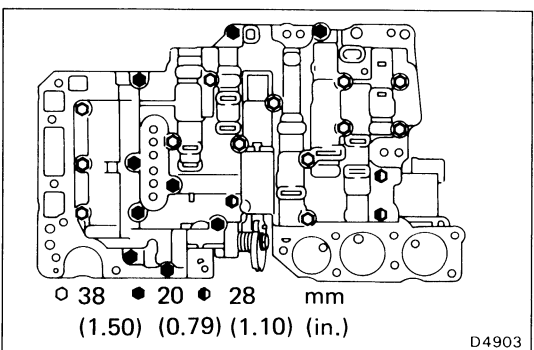

5. **INSTALL THE TWENTY-FIVE BOLTS TO UPPER VALVE BODY**  
HINT: Each bolt length (mm, in.) is indicated in the figure.  
Torque: 65 kg-cm (56 in.-lb, 6.4 N·m)

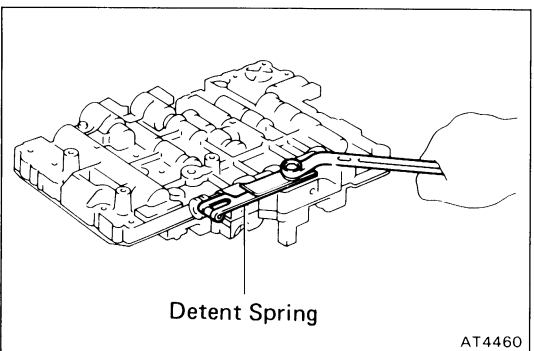

6. **INSTALL MANUAL VALVE**
7. **INSTALL DETENT SPRING**  
Torque: 100 kg-cm (7 ft-lb, 10 N·m)

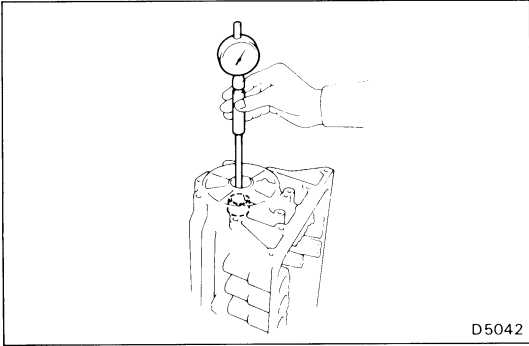

## Transmission Case

### INSPECTION OF TRANSMISSION CASE

#### INSPECT TRANSMISSION CASE BUSHING

Using a cylinder gauge, measure the inside diameter of the transmission case rear bushing.

**Maximum inside diameter: 38.19 mm (1.5035 in.)**

If the inside diameter is greater than the maximum, replace the transmission case.

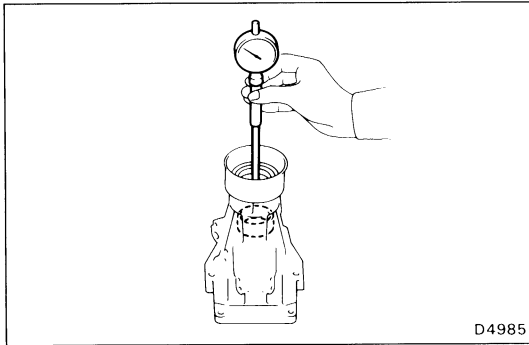

## Extension Housing

### INSPECTION OF EXTENSION HOUSING

#### 1. INSPECT EXTENSION HOUSING BUSHING

Using a cylinder gauge, measure the inside diameter of the extension housing bushing.

**Maximum inside diameter: 40.09 mm (1.5783 in.)**

If the inside diameter is greater than the maximum, replace the extension housing.

#### 2. IF NECESSARY, REPLACE OIL SEAL

(a) Using SST, remove the oil seal.

SST 09308-00010 or

09308-10010 with output shaft installed

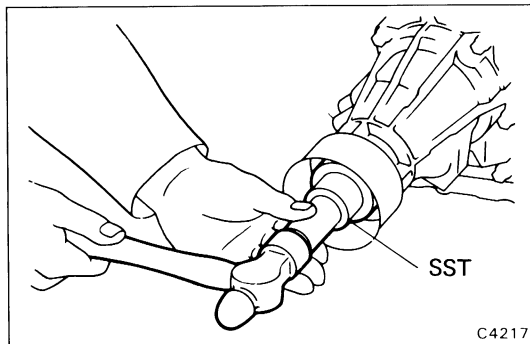
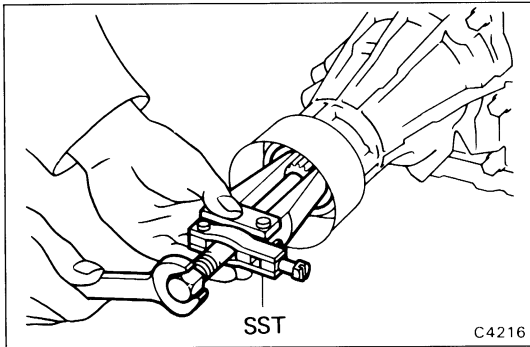

(b) Using SST, drive in a new oil seal as far as it will go.

SST 09325-40010

(c) Coat the oil seal lip with MP grease.

## INSTALLATION OF COMPONENT PARTS

(See pages AT-46 to 48)

Disassembly, inspection and assembly of each component group have been indicated in the preceding chapter. Before assembly, make sure again that all component groups are assembled correctly.

If something wrong is found in a certain component group during assembly, inspect and repair this group immediately.

Recommended ATF: DEXRON® II

### GENERAL NOTES:

1. The automatic transmission is composed of highly precision-finished parts, necessitating careful inspection before assembly because even a small nick could cause fluid leakage or affect performance.
2. Before assembling new clutch discs, soak them in automatic transmission fluid for at least two hours.
3. Apply automatic transmission fluid on sliding or rotating surfaces of parts before assembly.
4. Use petroleum jelly to keep small parts in their place.
5. Do not use adhesive cements on gaskets and similar parts.
6. When assembling the transmission, sure to use new gaskets and O-rings.
7. Dry all parts with compressed air — never use shop rags.
8. When working with FIPG material, you must be observe the following.
  - Using a razor blade and gasket scraper, remove all the old packing (FIPG) material from the gasket surfaces.
  - Thoroughly clean all components to remove all the loose material.
  - Clean both sealing surfaces with a non-residue solvent.
  - Parts must be assembled within 10 minutes of application. Otherwise, the packing (FIPG) material must be removed and reapplied.

INSTALLATION POSITION AND DIRECTION OF BEARINGS AND RACES

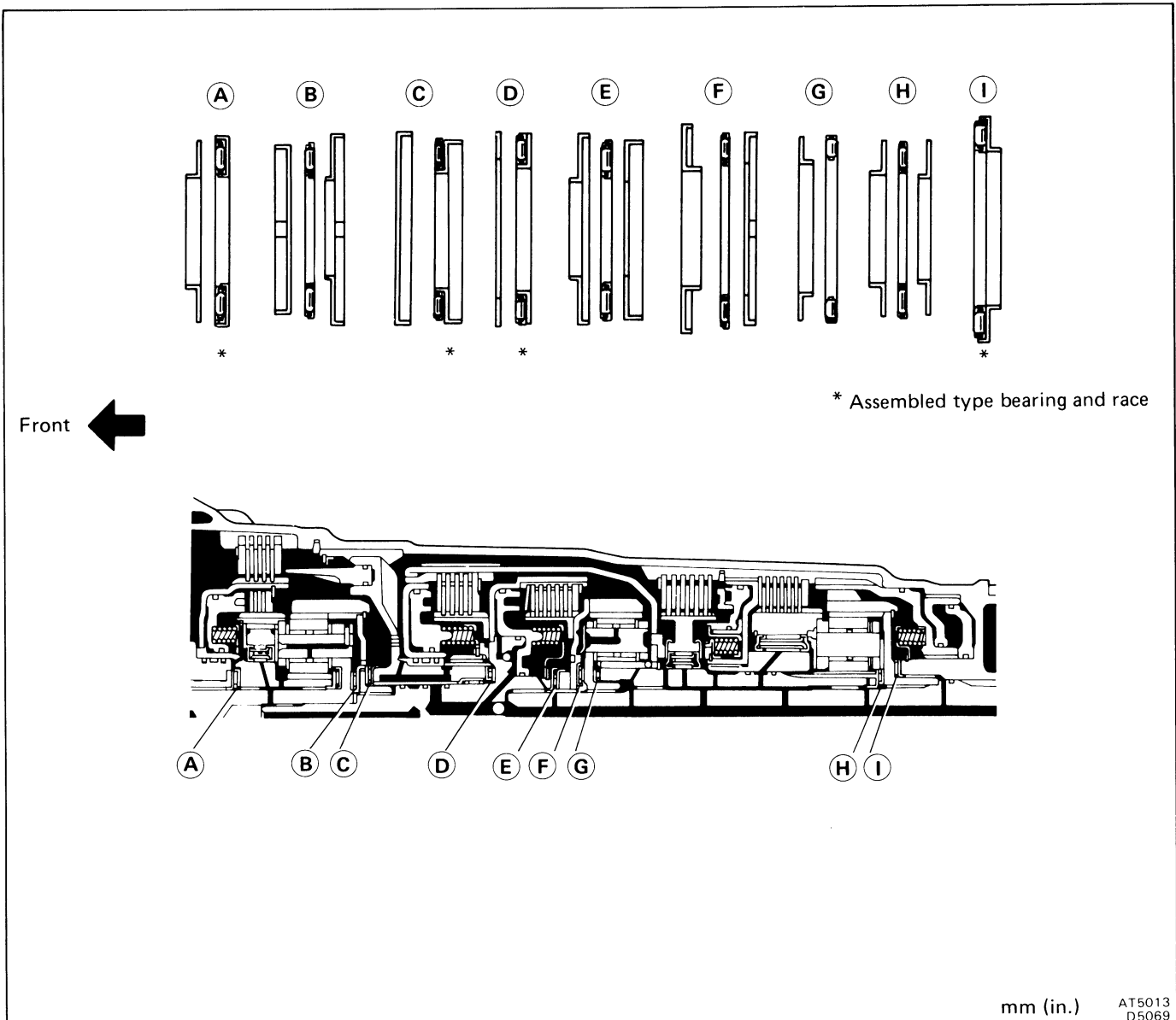

mm (in.) AT5013  
D5069

	Front Bearing Race		Thrust Bearing		Rear Bearing Race	
	Inner Diameter	Outer Diameter	Inner Diameter	Outer Diameter	Inner Diameter	Outer Diameter
Ⓐ	28.1 (1.106)	47.3 (1.862)	28.9 (1.138)	50.2 (1.976)	—	—
Ⓑ	27.1 (1.067)	41.8 (1.646)	26.0 (1.024)	46.8 (1.843)	24.2 (0.953)	47.8 (1.882)
Ⓒ	37.2 (1.465)	58.8 (2.315)	33.7 (1.327)	51.1 (2.012)	—	—
Ⓓ	36.8 (1.449)	50.9 (2.004)	33.7 (1.327)	47.6 (1.874)	—	—
Ⓔ	26.0 (1.024)	48.9 (1.925)	26.0 (1.024)	46.7 (1.839)	26.8 (1.055)	47.0 (1.850)
Ⓕ	30.6 (1.205)	53.6 (2.110)	32.6 (1.283)	47.7 (1.878)	34.3 (1.350)	47.8 (1.882)
Ⓖ	33.7 (1.327)	47.6 (1.874)	35.5 (1.398)	47.7 (1.878)	—	—
Ⓗ	28.8 (1.134)	44.8 (1.764)	30.1 (1.185)	44.7 (1.760)	27.8 (1.094)	44.8 (1.764)
Ⓘ	—	—	39.2 (1.543)	57.7 (2.272)	—	—



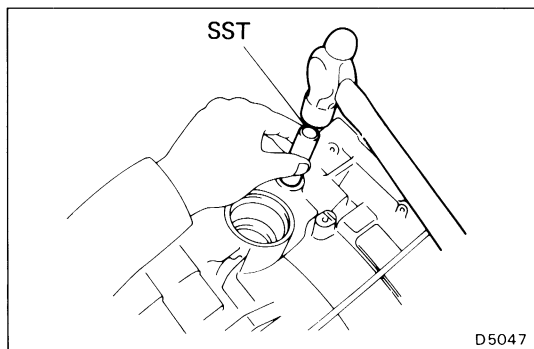

D5047

**1. INSTALL MANUAL VALVE LEVER, SHAFT AND OIL SEALS**

- (a) Using SST, drive in two new oil seals.
- SST 09350-30020 (09350-07110)
- (b) Coat the oil seal lip with MP grease.

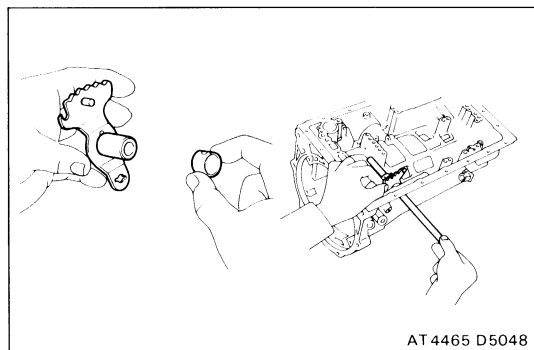

AT 4465 D5048

- (c) Assemble a new spacer to the manual valve lever.
- (d) Install the manual valve lever shaft to the transmission case through the manual valve lever.

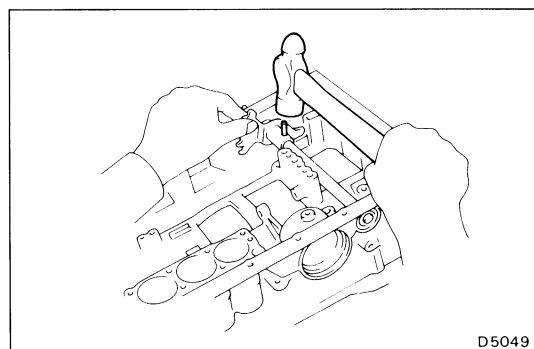

D5049

- (e) Drive in the pin to the shaft.

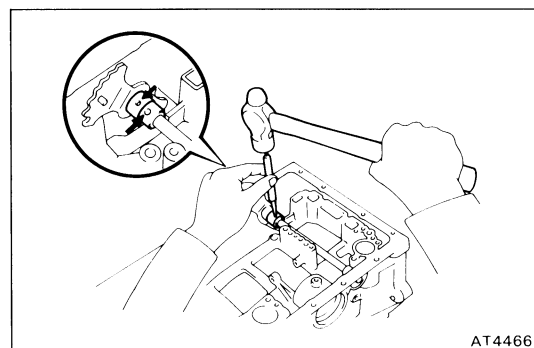

AT4466

- (f) Match the spacer hole to the lever calking hollow and calk the spacer to the lever.
- (g) Make sure the manual valve lever shaft turns smoothly.

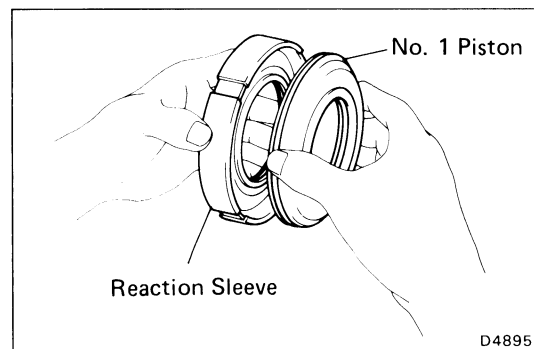

D4895

**2. INSTALL COMPONENTS OF FIRST AND REVERSE BRAKE PISTON**

- (a) Coat three new O-rings with ATF.
- (b) Install the two O-rings on No. 1 piston.
- (c) Install the O-ring on the reaction sleeve.
- (d) Install No. 1 piston to the reaction sleeve.

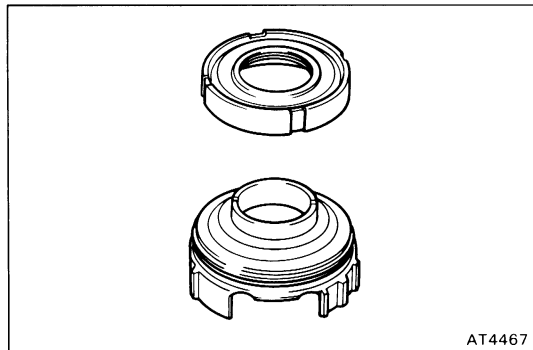

- (e) Coat a new O-ring with ATF and install it on No. 2 piston.
- (f) Install No. 1 piston with reaction sleeve onto No. 2 piston.

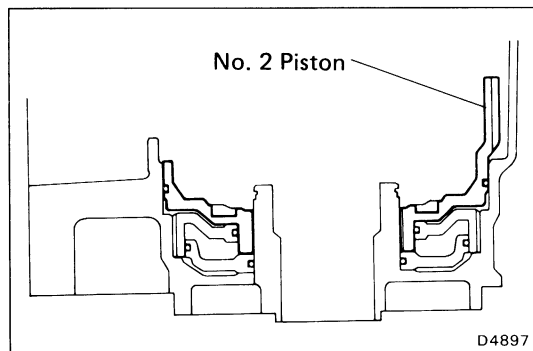

- (g) Align the teeth of No. 2 piston into the proper grooves.
- (h) Being careful not to damage the O-rings, press in No. 2 and No. 1 first and reverse brake pistons into the transmission case.

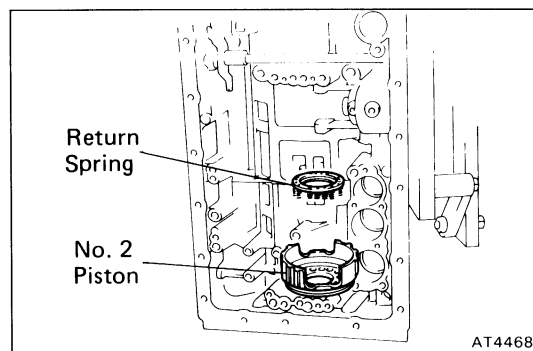

- (i) Place the piston return spring onto No. 2 piston.

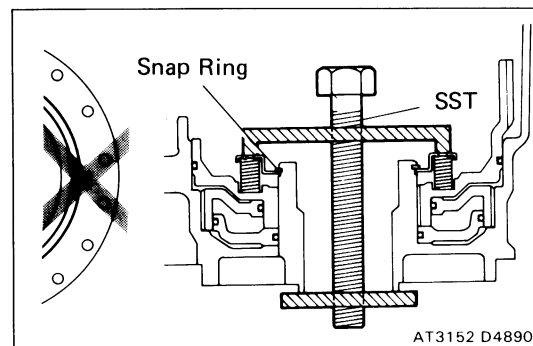

- (j) Set SST as shown, and compress the return spring with SST.

SST 09350-30020 (09350-07050)

- (k) Install the snap ring with a screwdriver. Be sure the end gap of the snap ring is not aligned with the spring retainer claw.

### 3. CHECK FIRST AND REVERSE BRAKE PISTONS MOVING

Make sure the first and reverse brake pistons move smoothly when applying and releasing the compressed air into the transmission case.

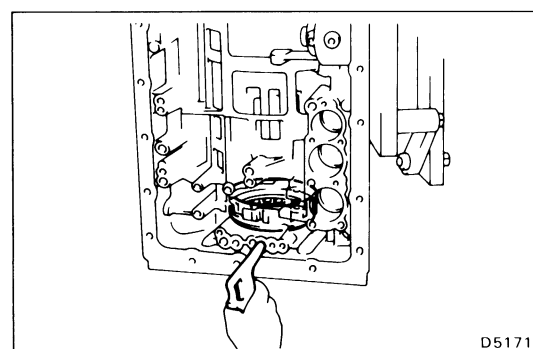

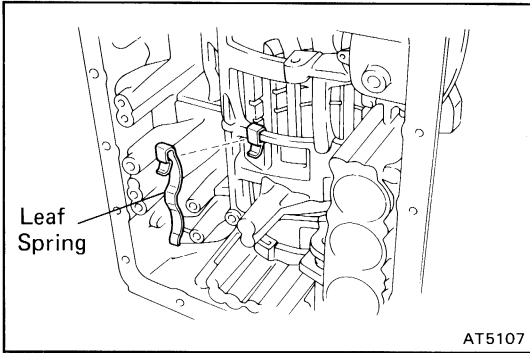

**4. INSTALL LEAF SPRING**

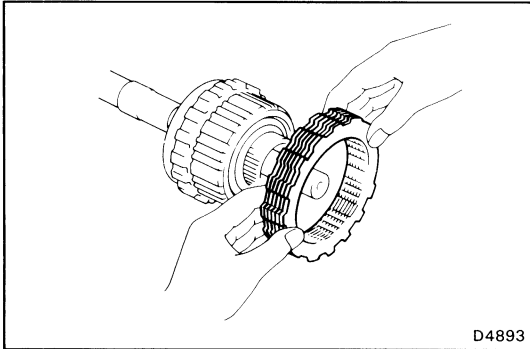

**5. INSTALL REAR PLANETARY GEAR UNIT WITH SECOND BRAKE DRUM, FIRST AND REVERSE BRAKE PACK AND OUTPUT SHAFT**

- (a) Re-install the original flange, the rounded edge facing forward.
- (b) Install the plates and discs.

Install in order: P=Plate D=Disc

7M-GE: D-P-D-P-D-P-D-P-D-P-D-P

7M-GTE: D-P-D-P-D-P-D-P-D-P-D-P-D-P

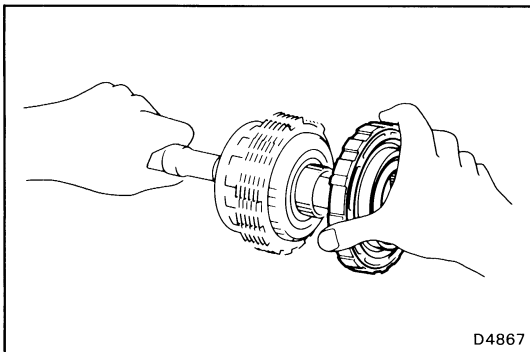

- (c) Install the second brake drum assembly.

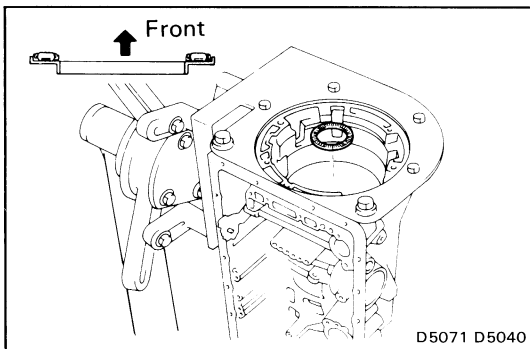

- (d) Coat the assembled bearing and race with petroleum jelly and install it onto the case.

HINT: Assembled bearing and race diameter

mm (in.)

	Inside	Outside
Bearing and Race	39.2 (1.543)	57.7 (2.272)

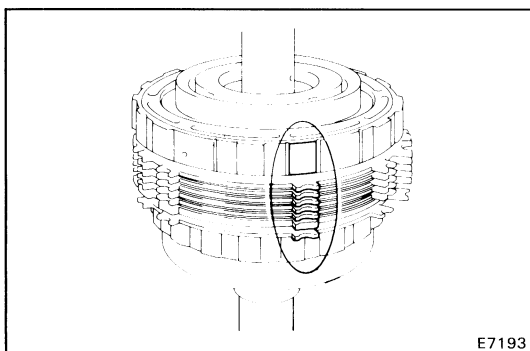

- (e) Align the teeth of the second brake drum, flange, discs and plates as shown in the figure.

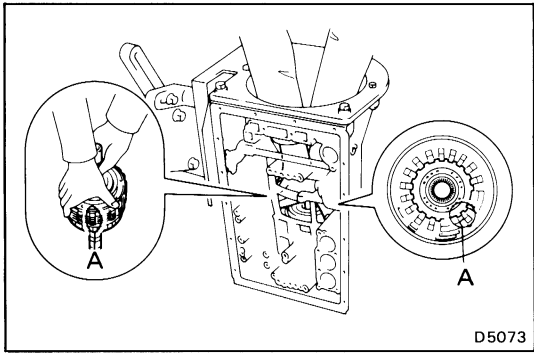

(f) Align the splines of the transmission case and the assembled rear planetary gear, second brake drum, first and reverse brake pack and output shaft, indicated by A.

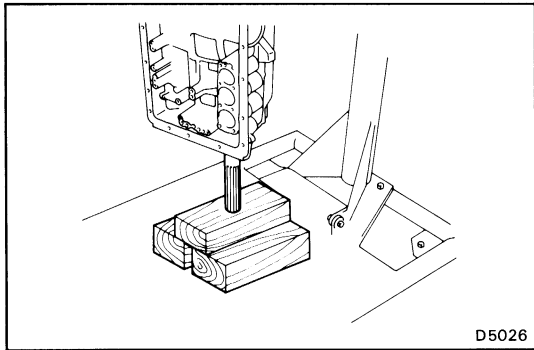

(g) Hold the output shaft with wooden blocks.

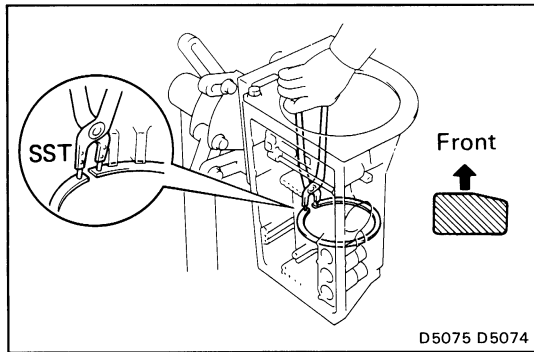

(h) Using SST, install the snap ring.  
SST 09350-30020 (09350-07060)

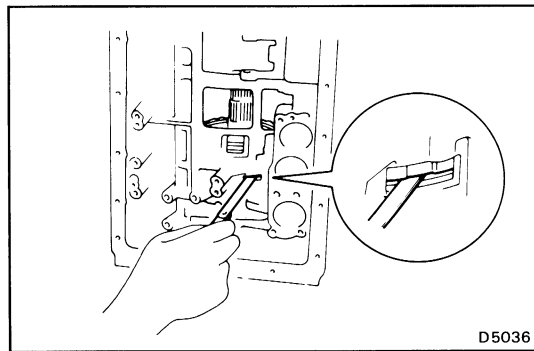

**6. CHECK PACK CLEARANCE OF FIRST AND REVERSE BRAKE**

Using a thickness gauge, measure the clearance between the plate and second brake drum as shown in the figure.

**Clearance:**

- 7M-GE** 0.60 – 1.12 mm (0.0236 – 0.0441 in.)
- 7M-GTE** 0.70 – 1.22 mm (0.0276 – 0.0480 in.)

If the values are nonstandard, select another flange.

**HINT:** There are six different thicknesses for the flange.

Flange thickness mm (in.)

No.	Thickness	No.	Thickness
50	5.0 (0.197)	53	4.4 (0.173)
51	4.8 (0.189)	54	4.2 (0.165)
52	4.6 (0.181)	55	4.0 (0.157)

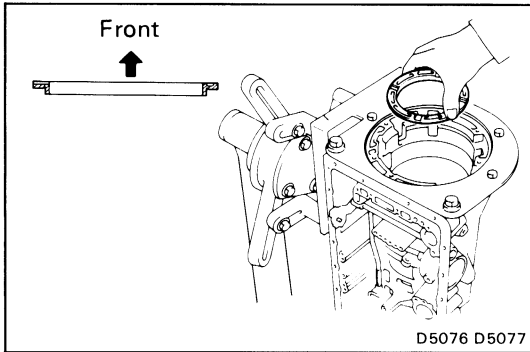

**7. INSTALL SECOND BRAKE PISTON SLEEVE**

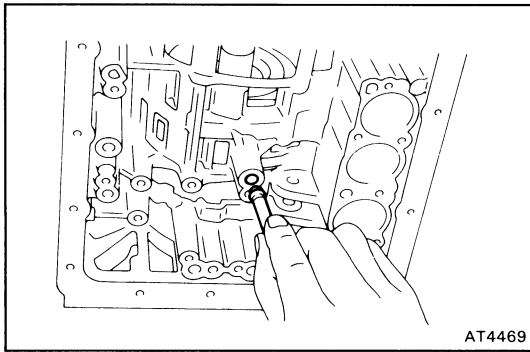

**8. INSTALL NEW BRAKE DRUM GASKET**

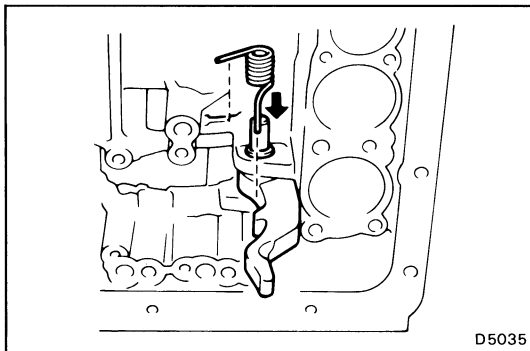

**9. INSTALL PARKING LOCK PAWL AND ROD**

- (a) Install the E-ring to the shaft.
- (b) Install the parking lock pawl, shaft and spring.

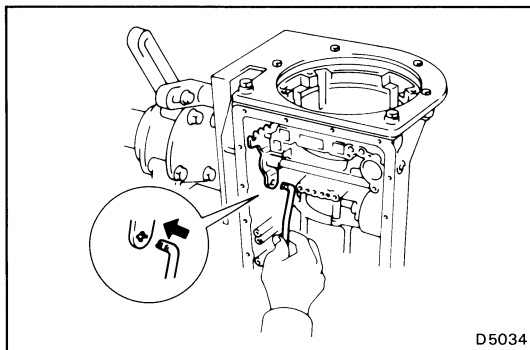

- (c) Connect the parking lock rod to the manual valve lever.

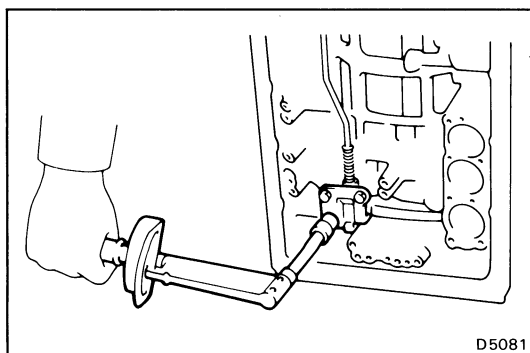

- (d) Install the parking lock pawl bracket and torque the bolts.

**Torque: 75 kg-cm (65 in.-lb, 7.4 N·m)**

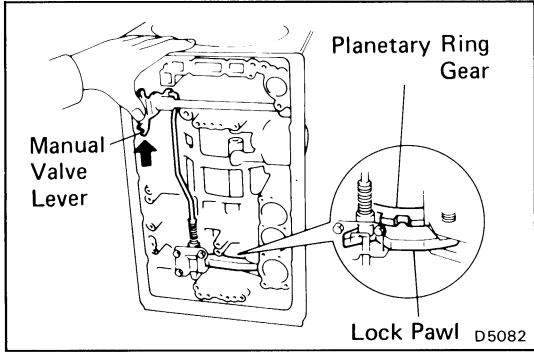

- (e) Shift the manual valve lever to the P position, and confirm the planetary ring gear is correctly locked up by the lock pal.

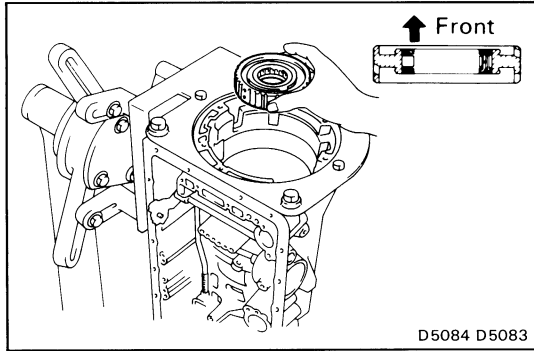

**10. INSTALL NO.1 ONE-WAY CLUTCH**

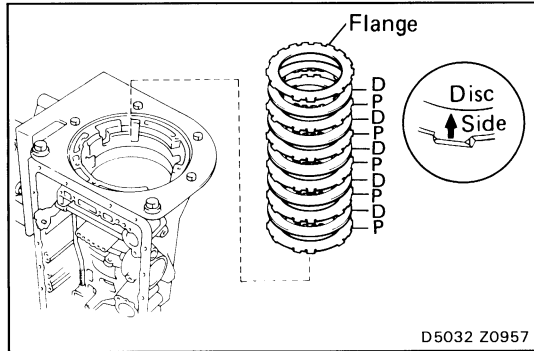

**11. INSTALL FLANGE, PLATES AND DISCS OF SECOND BRAKE**

- (a) Install the 1.8 mm (0.071 in.) thick plate with the rounded edge side of the plate facing the disc.
- (b) Install the plates and discs.  
Install in order: P = Plate D = Disc  
P-D-P-D-P-D-P-D-P-D
- (c) Install the flange with the rounded edge of the flange facing the disc.

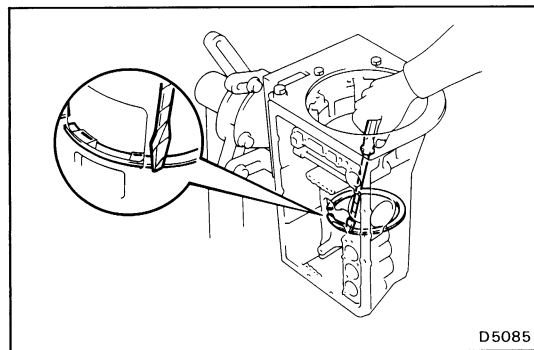

- (d) Install the snap ring.

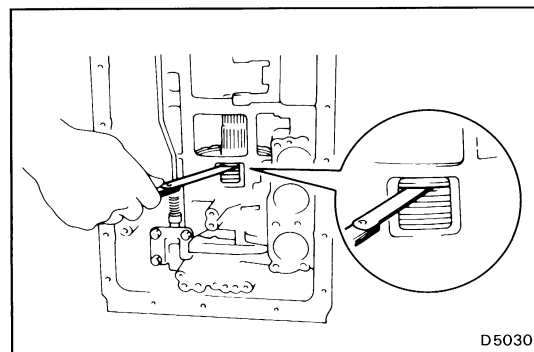

**12. CHECK PACK CLEARANCE OF SECOND BRAKE**

Using a thickness gauge, measure the clearance between the snap ring and flange as shown in the figure.  
**Clearance: 0.62 — 1.98 mm (0.0244 — 0.0780 in.)**  
 If the values are nonstandard, check for an improper installation.

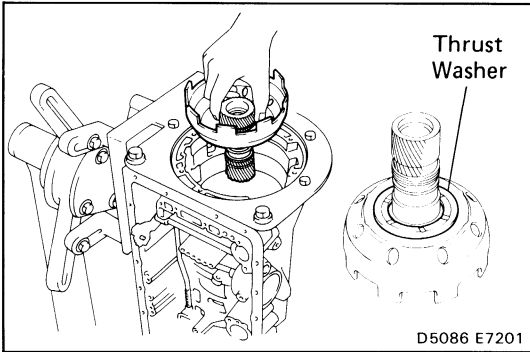

**13. INSTALL PLANETARY SUN GEAR**

While turning the planetary sun gear clockwise, install it into No.1 one-way clutch.

HINT: Confirm the thrust washer is installed correctly.

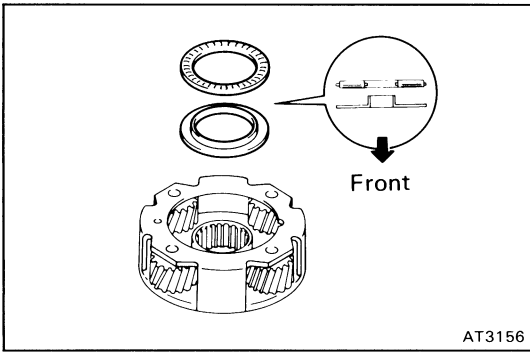

**14. INSTALL FRONT PLANETARY GEAR**

(a) Coat the bearing and race with petroleum jelly and install them onto the front planetary gear.

mm (in.)

	Inside	Outside
Bearing	35.5 (1.398)	47.7 (1.878)
Race	33.7 (1.327)	47.6 (1.874)

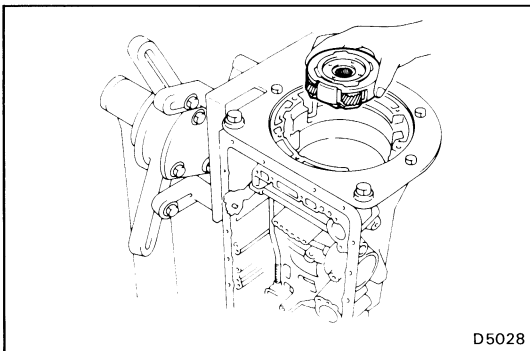

(b) Install the front planetary gear to the sun gear.

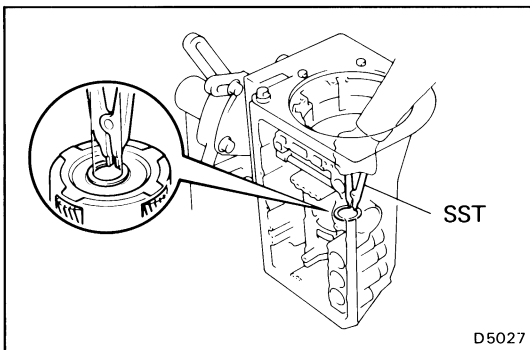

(c) Using SST, install the snap ring.

SST 09350-30020 (09350-07070)

(d) Remove the wooden blocks under the output shaft.

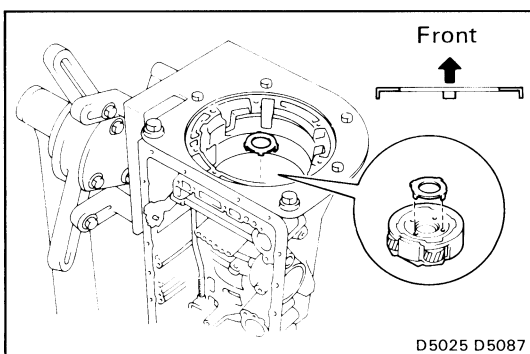

(e) Coat the bearing race with petroleum jelly and install it onto the front planetary gear.

HINT: Race diameter

mm (in.)

	Inside	Outside
Race	34.3 (1.350)	47.8 (1.882)

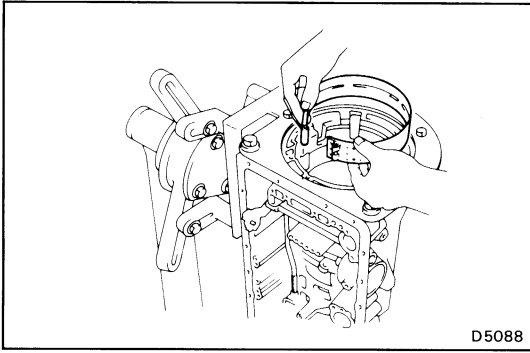

**15. INSTALL SECOND COAST BRAKE BAND**

(a) Insert the second coast brake band to the case.

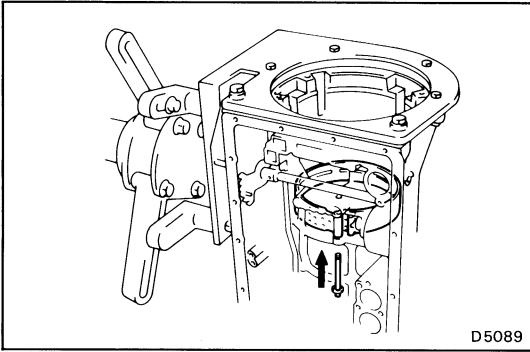

(b) Install the pin through the brake band.

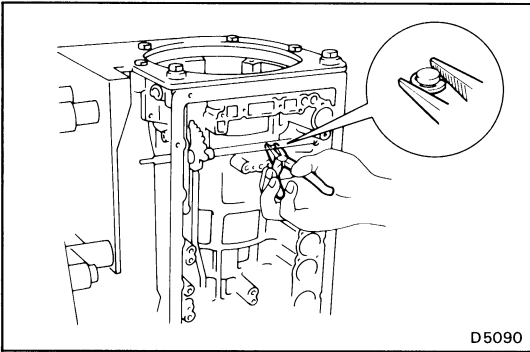

(c) Install the E-ring to the pin.

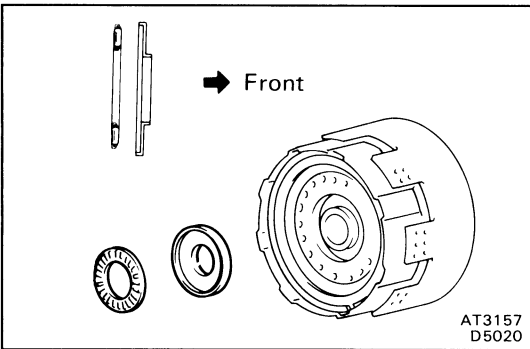

**16. INSTALL FRONT PLANETARY RING GEAR TO FORWARD AND DIRECT CLUTCH**

(a) Coat the bearing and race with petroleum jelly and install them onto the forward clutch.

HINT: Bearing and race diameter

mm (in.)

	Inside	Outside
Bearing	26.0 (1.024)	46.7 (1.839)
Race	26.0 (1.024)	48.9 (1.925)



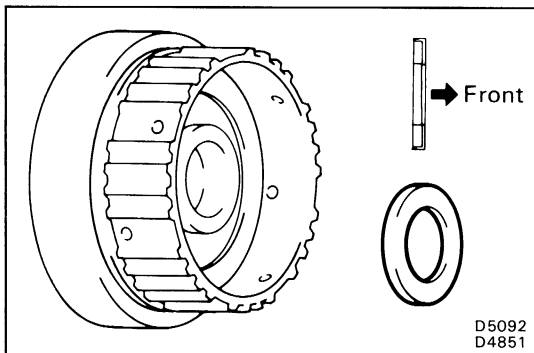

- (b) Coat the race with petroleum jelly and install it onto the front planetary ring gear.

HINT: Race diameter

mm (in.)

	Inside	Outside
Race	26.8 (1.055)	47.0 (1.850)

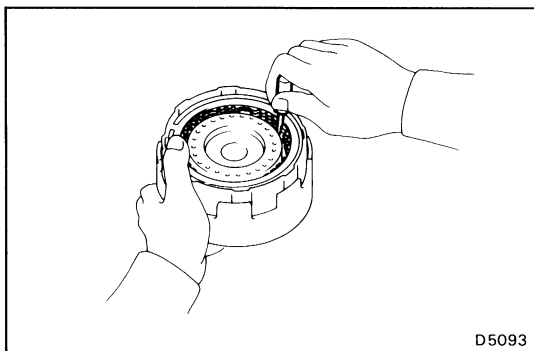

- (c) Align the flukes of the discs in the forward clutch.

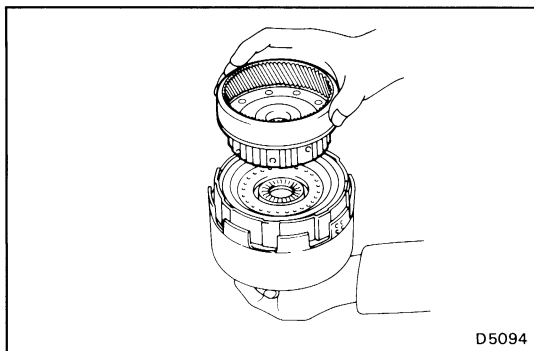

- (d) Align the splines of the front planetary ring gear with the flukes of the discs and install the front planetary ring gear to the forward clutch.

**17. INSTALL ASSEMBLED DIRECT CLUTCH, FORWARD CLUTCH AND FRONT PLANETARY RING GEAR INTO CASE**

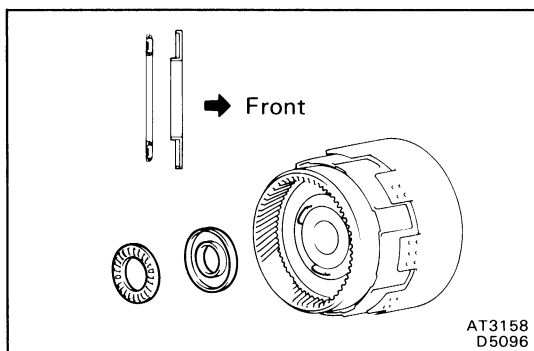

- (a) Coat the bearing and race with petroleum jelly and install them onto the ring gear.

HINT: Bearing and race diameter

mm (in.)

	Inside	Outside
Bearing	32.6 (1.283)	47.7 (1.878)
Race	30.6 (1.205)	53.6 (2.110)

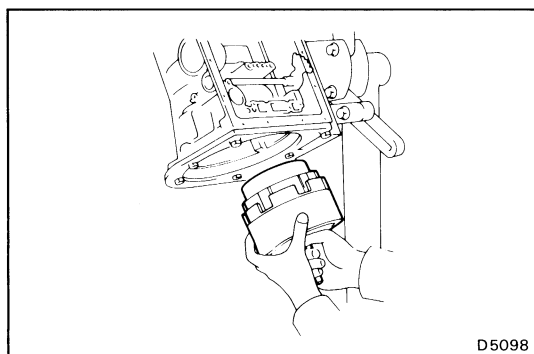

- (b) Install the assembled direct clutch, forward clutch and front planetary ring gear into the transmission case.

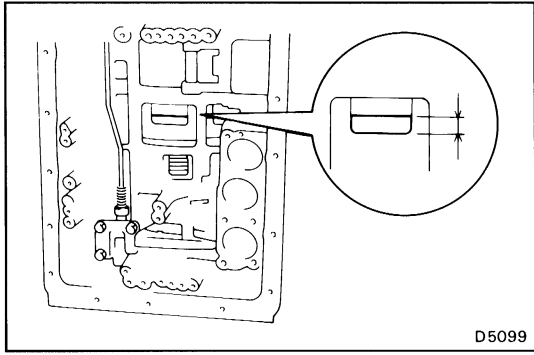

(c) Using vernier calipers, measure the distance between the sun gear input drum and direct clutch drum as shown in the figure.

**Height: 9.8 – 11.8 mm (0.386 – 0.465 in.)**

If the values are nonstandard, check for an improper installation.

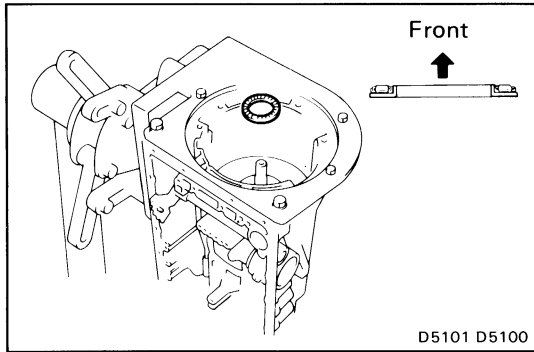

(d) Coat the assembled bearing and race with petroleum jelly and install it onto the forward clutch.

**HINT:** Assembled bearing and race diameter

mm (in.)

	Inside	Outside
Bearing and Race	33.7 (1.327)	47.6 (1.874)

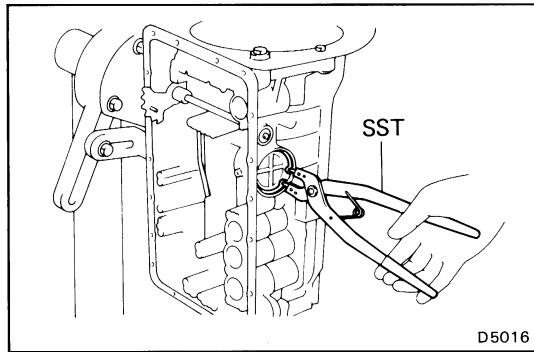

**18. INSTALL SECOND COAST BRAKE COVER, PISTON ASSEMBLY AND SPRING**

(a) Coat two new O-rings with ATF and install them to the cover.

(b) Install the spring, piston assembly and cover to the case.

(c) Using SST, install the snap ring.

SST 09350-30020 (09350-07060)

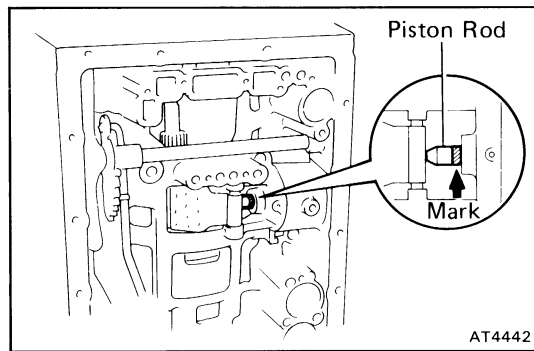

**19. CHECK PISTON ROD STROKE OF SECOND COAST BRAKE**

(a) Place a mark on the second coast brake piston rod as shown in the figure.

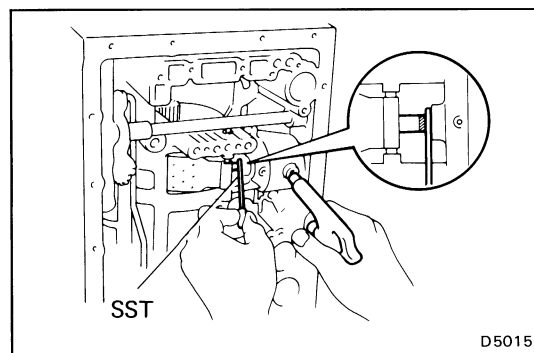

(b) Using SST, measure the stroke applying the compressed air (4 – 8 kg/cm<sup>2</sup>, 57 – 114 psi or 392 – 785 kPa) as shown in the figure.

SST 09240-00020

**Piston rod stroke: 1.5 – 3.0 mm (0.059 – 0.118 in.)**

If it is still more than standard value, replace the brake band with a new one.

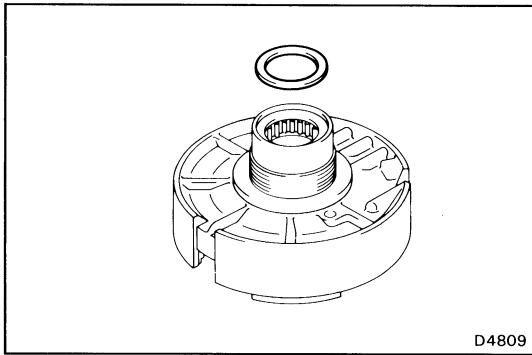

**20. INSTALL OVERDRIVE SUPPORT ASSEMBLY**

- (a) Coat the race with petroleum jelly and install it onto the overdrive support assembly.

HINT: Race diameter

mm (in.)

	Inside	Outside
Race	36.8 (1.449)	50.9 (2.004)

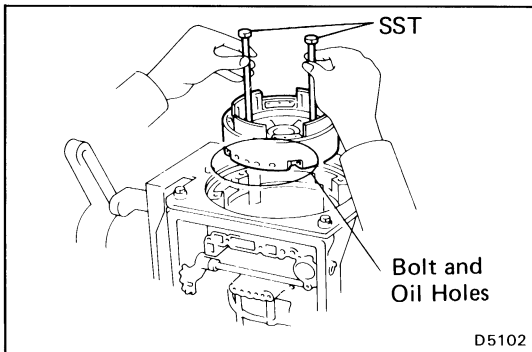

- (b) Using two bolts of SST, aim the bolt and oil holes of the overdrive support toward the valve body side, and align them with the bolt holes of the transmission case and insert.

SST 09350-30020 (09350-07020)

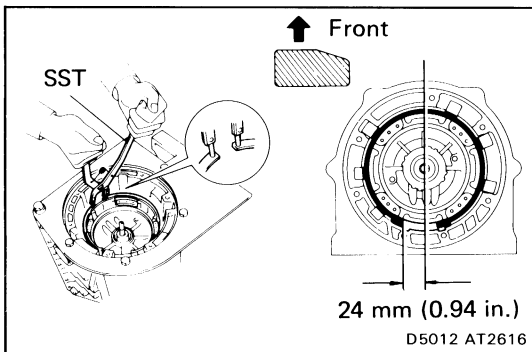

- (c) Using SST, install the snap ring as shown in the figure.

SST 09350-30020 (09350-07060)

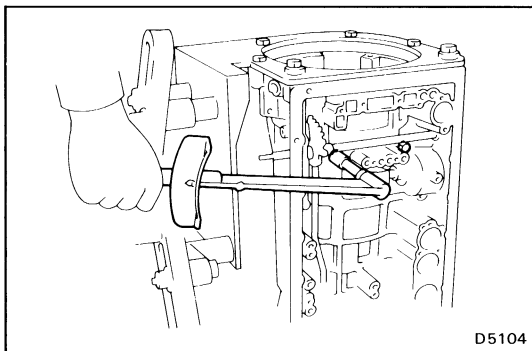

- (d) Install and torque the two bolts.

**Torque: 260 kg-cm (19 ft-lb, 25 N·m)**

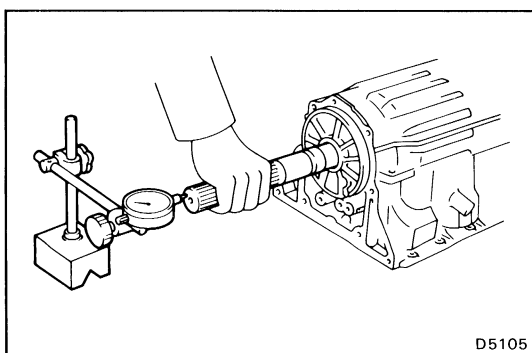

**21. CHECK OUTPUT SHAFT**

- (a) Using a dial indicator, measure the end play of the output shaft with hand.

**End play: 0.27 — 0.86 mm (0.0106 — 0.0339 in.)**

If the values are nonstandard, check for an improper installation.

- (b) Check to see that output shaft rotates smoothly.

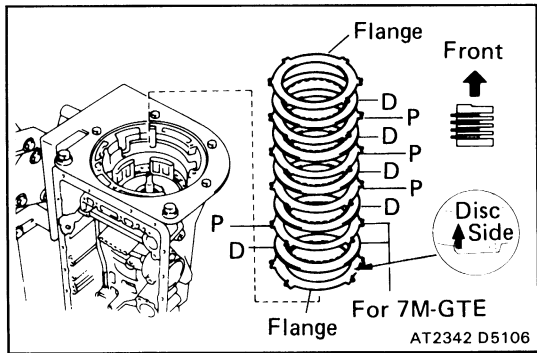

**22. INSTALL FLANGES, PLATES AND DISCS OF OVERDRIVE BRAKE**

- (a) Install the 4.0 mm (0.157 in.) thick flange (flat ring) with the rounded edge side of the flange facing the disc.
- (b) Install the plates and discs.

Install in order: P = Plate D = Disc  
 7M-GE: D-P-D-P-D-P-D  
 7M-GTE: D-P-D-P-D-P-D-P-D

- (c) Install the flange (stepped ring) with the flat side of the flange facing the disc.
- (d) Install the snap ring.

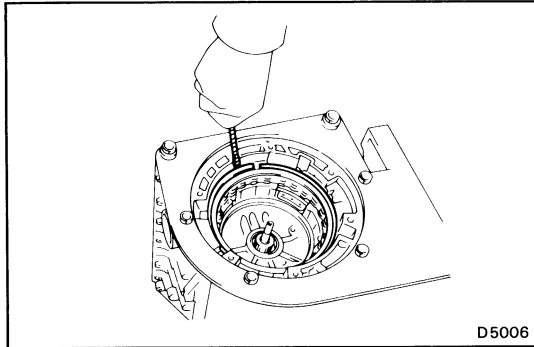

**23. CHECK PISTON STROKE OF OVERDRIVE BRAKE**

- (a) Place SST and a dial indicator onto the overdrive brake piston as shown in the figure.

SST 09350-30020 (09350-06120)

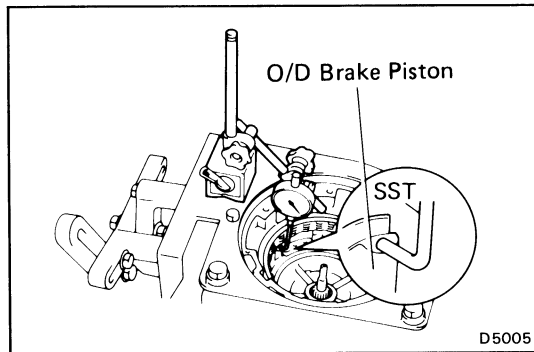

- (b) Measure the stroke applying and releasing the compressed air (4 – 8 kg/cm<sup>2</sup>, 57 – 114 psi or 392 – 785 kPa) as shown in the figure.

**Piston stroke:**  
 7M-GE: 1.40 – 1.70 mm (0.0551 – 0.0669 in.)  
 7M-GTE: 1.75 – 2.05 mm (0.0689 – 0.0807 in.)

If the piston stroke is less than the limit, parts may have been assembled incorrectly, check and reassemble again.

If the piston stroke is nonstandard, select another flange.

**HINT:** There are seven different thicknesses for the flange.

Flange thickness mm (in.)

No.	Thickness	No.	Thickness
26	3.3 (0.130)	11	3.8 (0.150)
25	3.5 (0.138)	23	3.9 (0.154)
12	3.6 (0.142)	None	4.0 (0.157)
24	3.7 (0.146)		

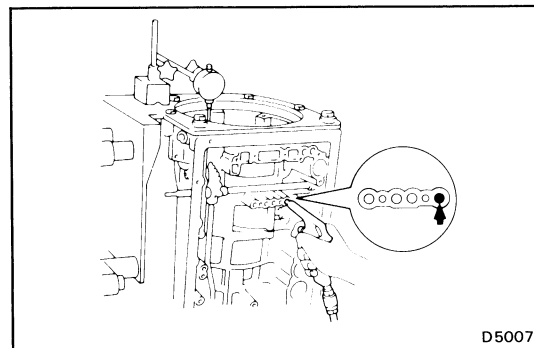

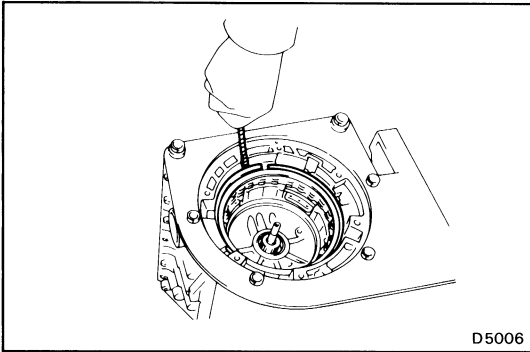

**24. REMOVE FLANGES, PLATES AND DISCS OF OVERDRIVE BRAKE**

(a) Remove the snap ring.

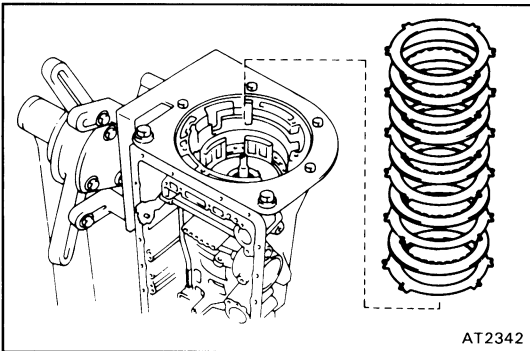

(b) Remove the flanges, plates and discs.

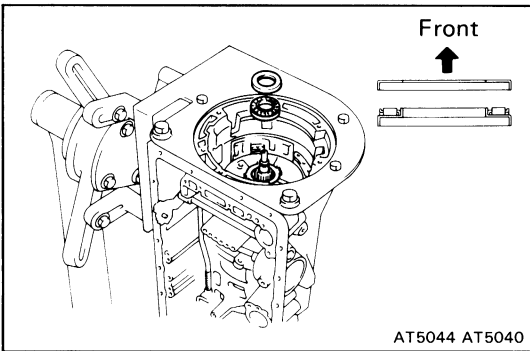

**25. INSTALL OVERDRIVE GEAR UNIT WITH OVERDRIVE DIRECT CLUTCH AND ONE-WAY CLUTCH**

(a) Coat the bearing and race with petroleum jelly and install them onto the overdrive support.

HINT: Bearing and race diameter

mm (in.)

	Inside	Outside
Bearing	33.7 (1.327)	51.1 (2.012)
Race	37.2 (1.465)	58.8 (2.315)

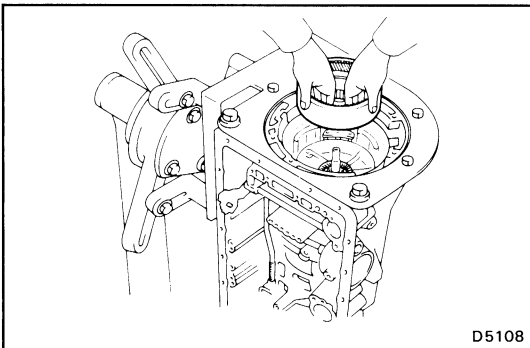

(b) Install the overdrive planetary ring gear.

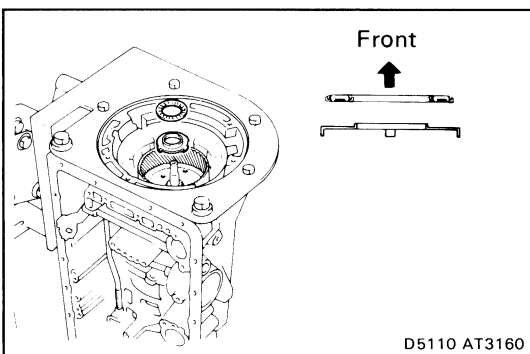

(c) Coat the bearing and race with petroleum jelly and install them onto the planetary ring gear.

HINT: Bearing and race diameter

mm (in.)

	Inside	Outside
Bearing	26.0 (1.024)	46.8 (1.843)
Race	24.2 (0.953)	47.8 (1.882)

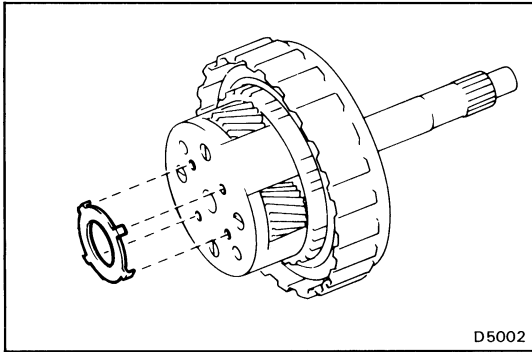

(d) Coat the race with petroleum jelly and install it onto the planetary gear.

HINT: Race diameter

mm (in.)

	Inside	Outside
Race	27.1 (1.067)	41.8 (1.646)

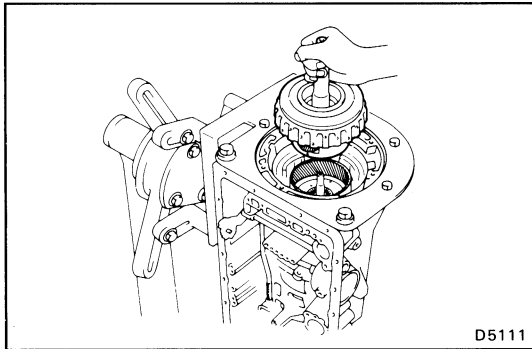

(e) Install the over drive planetary gear with the overdrive direct clutch and one-way clutch.

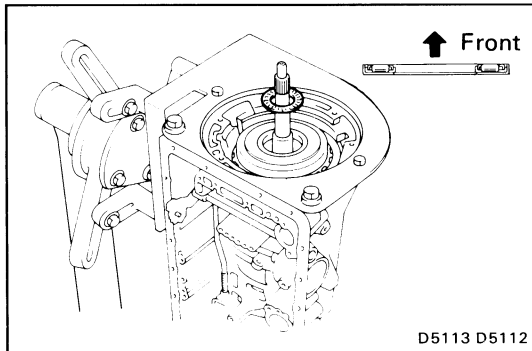

(f) Coat the assembled bearing and race with petroleum jelly and install it onto the O/D direct clutch.

HINT: Assembled bearing and race diameter

mm (in.)

	Inside	Outside
Bearing and Race	28.9 (1.138)	50.2 (1.976)

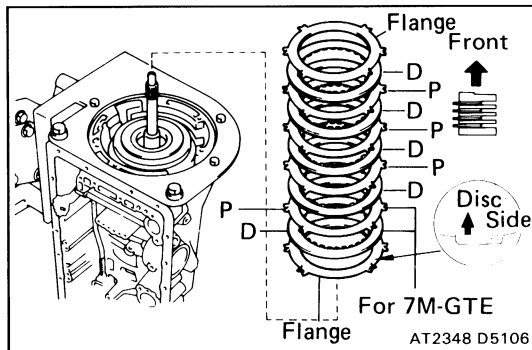

**26. INSTALL FLANGES, PLATES AND DISCS OF OVERDRIVE BRAKE**

(a) Install the 4.0 mm (0.157 in.) thick flange (flat ring) with the rounded edge side of the flange facing the disc.

(b) Install the plates and discs.

Install in order: P = Plate D = Disc

7M-GE: D-P-D-P-D-P-D

7M-GTE: D-P-D-P-D-P-D-P-D

(c) Install the flange (stepped ring) with the flat side of the flange facing the disc.

(d) Install the snap ring.

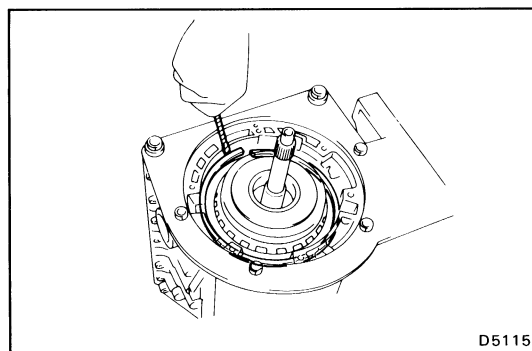

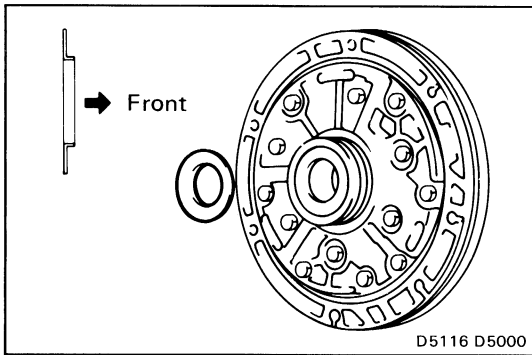

**27. INSTALL OIL PUMP INTO CASE**

- (a) Coat the race with petroleum jelly and install it onto the oil pump.

HINT: Race diameter

mm (in.)

	Inside	Outside
Race	28.1 (1.106)	47.3 (1.862)

- (b) Coat the new O-ring with ATF and install it around the pump body.
- (c) Place the oil pump through the input shaft, and align the bolt holes of the pump body with the transmission case.
- (d) Hold the input shaft, and lightly press the oil pump body to slide the oil seal rings into the O/D direct clutch drum.

**NOTICE:** Do not push on the oil pump strongly, or the oil seal ring will stick to the direct clutch drum.

- (e) Install the seven bolts.

**Torque:** 220 kg-cm (16 ft-lb, 22 N·m)

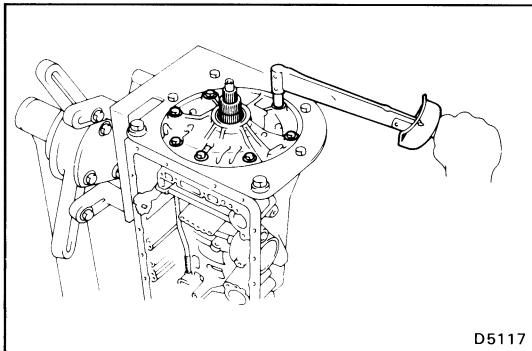

**28. CHECK INPUT SHAFT ROTATION**

Make sure the input shaft rotates smoothly.

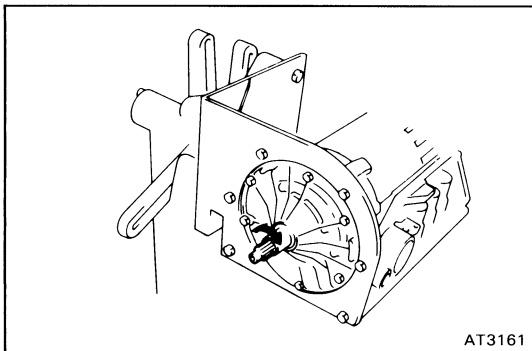

**29. INSTALL THROTTLE CABLE**

- (a) Coat a new O-ring with ATF and install it to the cable.
- (b) Install the cable to the case.

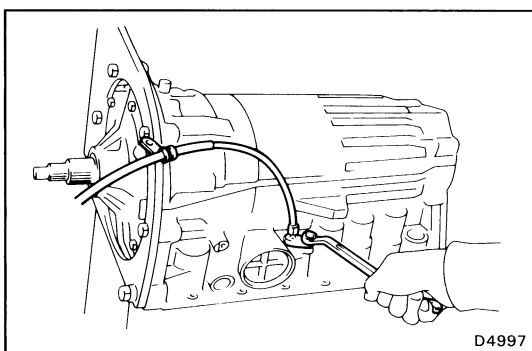

**30. INDIVIDUAL PISTON OPERATION INSPECTION**

Check for the sound of operation while applying compressed air into the oil hole indicated in the figure.

- (1) O/D direct clutch
- (2) Direct clutch
- (3) Forward clutch
- (4) O/D brake
- (5) Second coast brake
- (6) Second brake
- (7) First and reverse brake

HINT: When inspecting the O/D direct clutch, check with the C<sub>0</sub> accumulator piston hole closed.

If there is no noise, disassemble and check the installation condition of the parts.

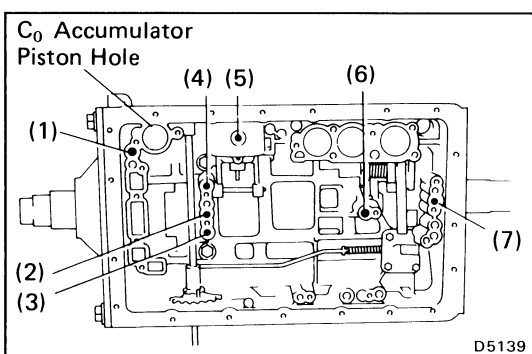

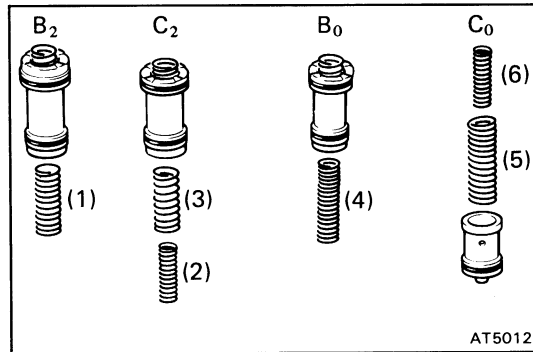
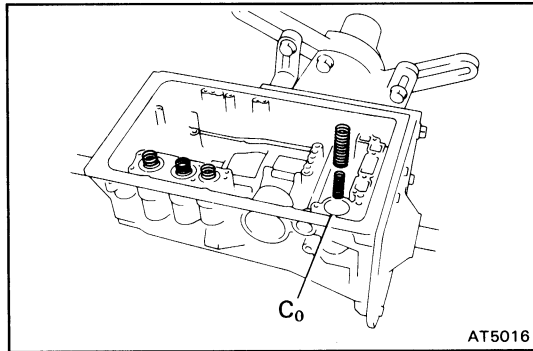
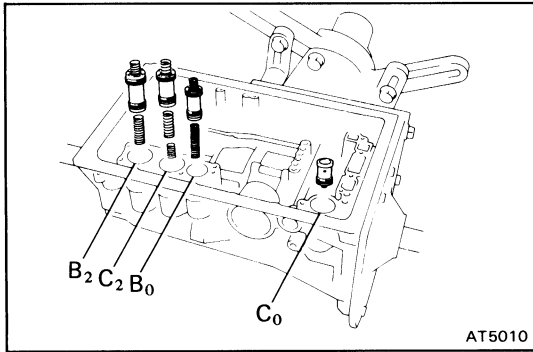

**31. INSTALL ACCUMULATOR SPRINGS, PISTONS AND PINS**

- (a) Coat new O-rings with ATF and install them to the pistons.
- (b) Install the four springs and four accumulator pistons to the bore as shown in the figure.

**HINT:** The pistons are marked in relief with either C<sub>0</sub>, B<sub>0</sub>, C<sub>2</sub> or B<sub>2</sub> to the discriminate between them.

- (c) Install the two springs to the C<sub>0</sub> accumulator piston.

**• Spring**

mm (in.)

		Spring	Free length	Outer diameter	Color	
(1)	B <sub>2</sub>	7M-GE	73.4 (2.890)	19.9 (0.783)	Red	
		7M-GTE	72.6 (2.858)	19.9 (0.783)	Light Gray	
(2)	C <sub>2</sub>	Inner	42.1 (1.657)	14.7 (0.579)	Pink	
(3)		Outer	7M-GE	64.0 (2.520)	20.2 (0.795)	Green
			7M-GTE	70.3 (2.768)	20.2 (0.795)	Pink
(4)		B <sub>0</sub>	62.0 (2.441)	16.0 (0.630)	Green	
(5)	C <sub>0</sub>	Outer	74.6 (2.937)	20.9 (0.823)	Orange	
(6)		Inner	46.0 (1.811)	14.0 (0.551)	Yellow	

**32. INSTALL CHECK BALL BODY AND SPRING**

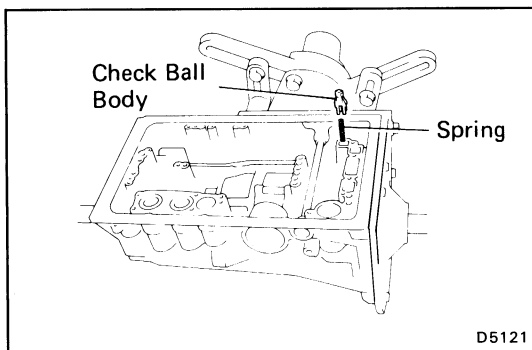

**33. INSTALL VALVE BODY**

- (a) Align the groove of the manual valve to the pin of the lever.

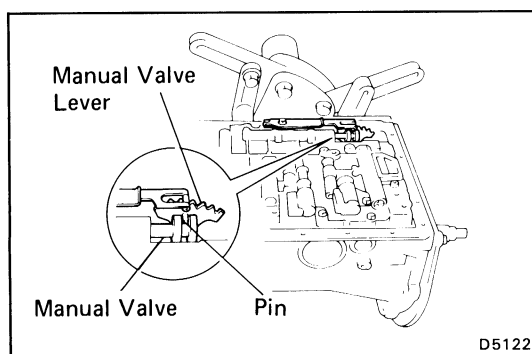



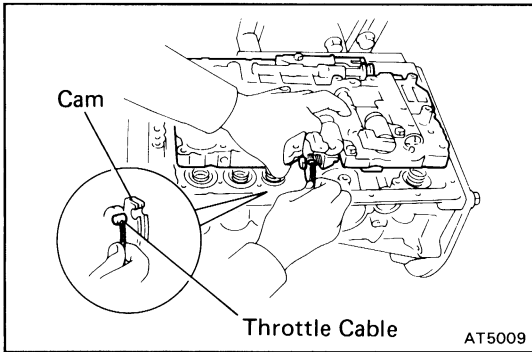

- (b) Connect the throttle cable to the cam.
- (c) Confirm the springs into the accumulator pistons are installed correctly.

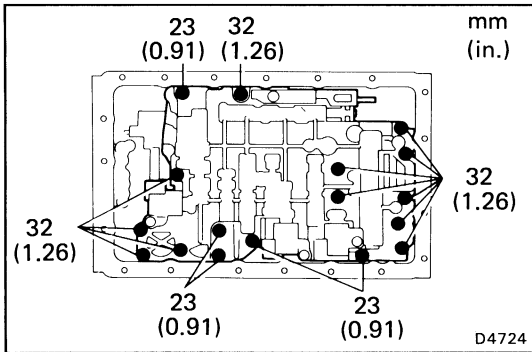

- (d) Install the seventeen bolts.
- HINT: Each bolt length (mm, in.) is indicated in the figure.  
**Torque: 100 kg-cm (7 ft-lb, 10 N·m)**

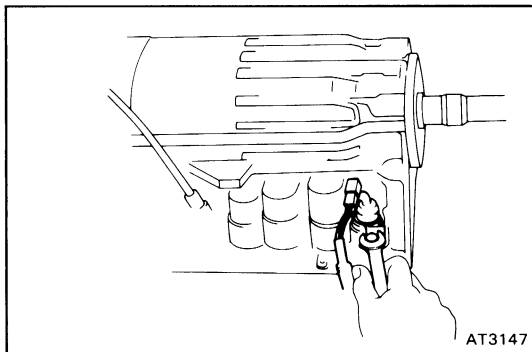

**34. INSTALL SOLENOID WIRING**

- (a) Coat a new O-ring with ATF and install it to the grommet.
- (b) Insert the solenoid wiring to the case and install the stopper plate.

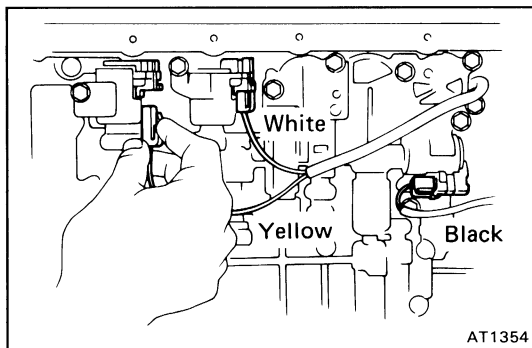

- (c) Connect the connectors to No.1, No.2 and lock-up solenoid.

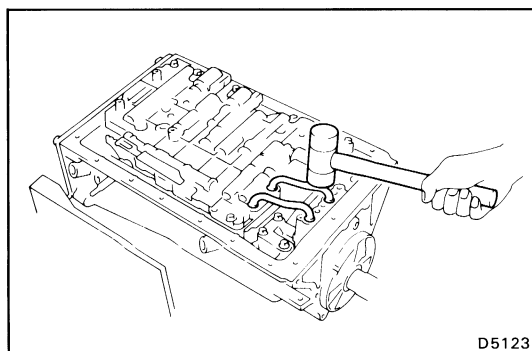

**35. INSTALL OIL TUBES**

Using a plastic hammer, install the two tubes into positions shown in the figure.

**NOTICE: Be careful not to bend or damage the tubes.**

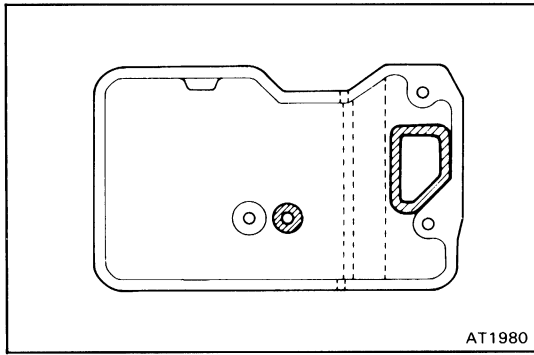

### 36. INSTALL OIL STRAINER AND GASKETS

(a) Install two new gaskets to the oil strainer.

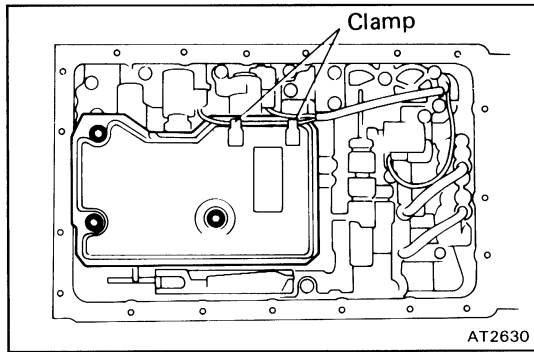

(b) Install and torque the three bolts.

**Torque: 100 kg-cm (7 ft-lb, 10 N-m)**

(c) Clamp the solenoid wire.

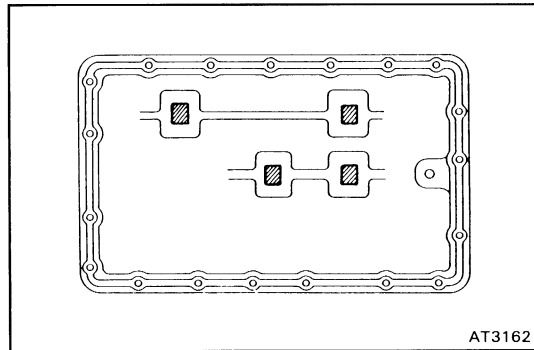

### 37. INSTALL MAGNETS IN PAN

Install the four magnets in the indentations of the oil pan as shown in the figure.

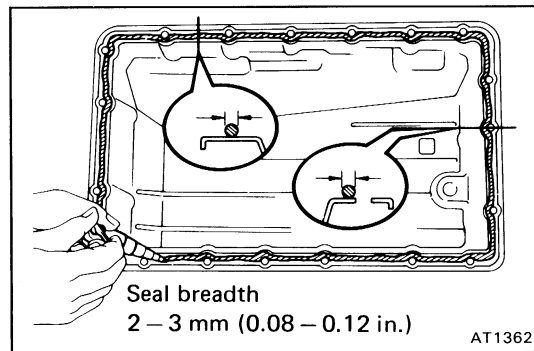

### 38. INSTALL OIL PAN

(a) Remove any packing material and be careful not to drop oil on the contacting surfaces of the transmission case and oil pan.

(b) Apply seal packing to the oil pan as shown in the figure.

**Seal packing: Part No. 08826-00090, THREE BOND 1281 or equivalent**

(c) Install and torque the nineteen bolts.

**Torque: 75 kg-cm (65 in.-lb, 7.4 N-m)**

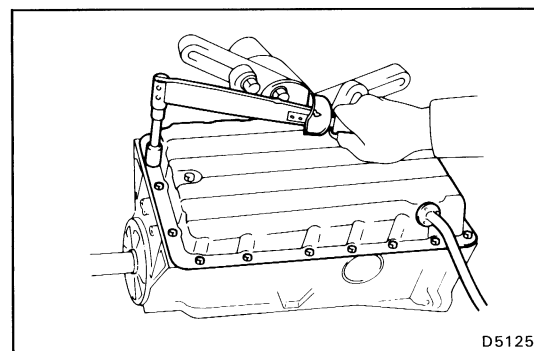

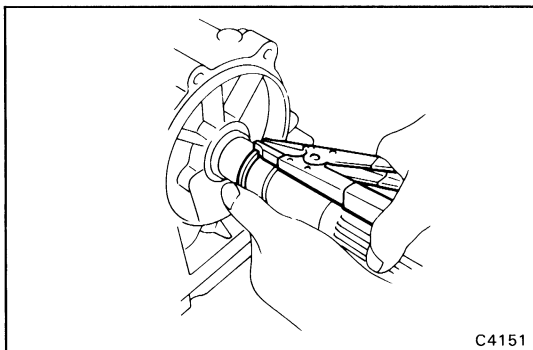
**39. INSTALL SENSOR ROTOR AND KEY**

- (a) Using snap ring pliers, install the snap ring.

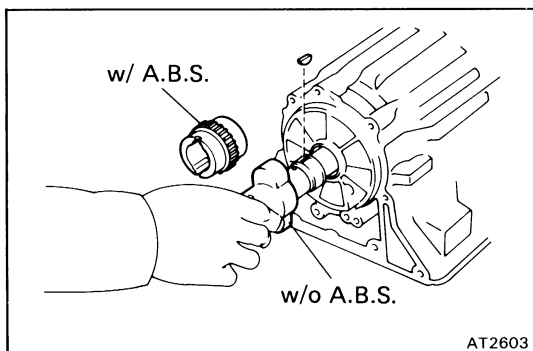

- (b) Install the key on the output shaft.  
 (c) Align the groove of the sensor rotor with the key, install the sensor rotor.

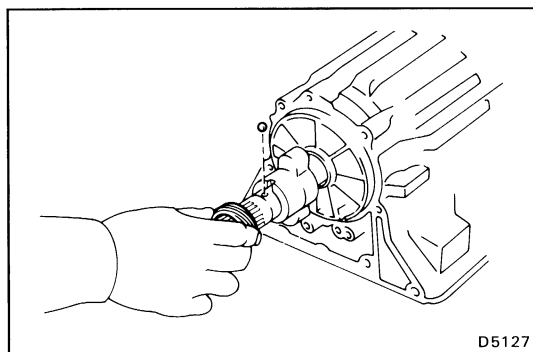
**40. INSTALL SPEEDOMETER DRIVE GEAR AND BALL**

- (a) Install the lock ball on the output shaft.  
 (b) Align the groove of the drive gear with the ball, install the drive gear.

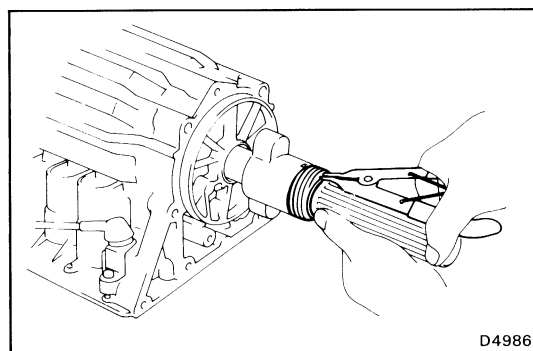

- (c) Using snap ring pliers, install the snap ring.

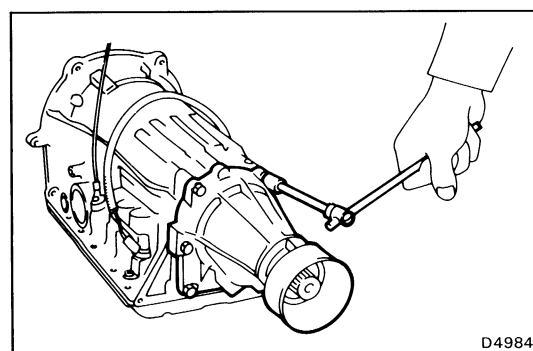
**41. INSTALL EXTENSION HOUSING AND NEW GASKET**

Install the extension housing with a new gasket to the case.  
 Install and torque the six bolts.

HINT: The two lower bolts are shorter.

**Torque: 370 kg-cm (27 ft-lb, 36 N·m)**

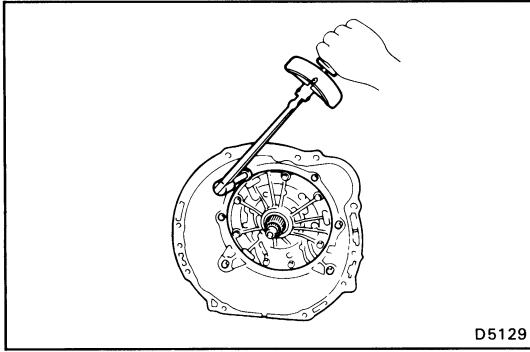
**42. INSTALL TRANSMISSION HOUSING**

Install and torque the six bolts.

**Torque:** 10 mm Bolt 345 kg-cm (25 ft-lb, 34 N·m)  
 12 mm Bolt 580 kg-cm (42 ft-lb, 57 N·m)

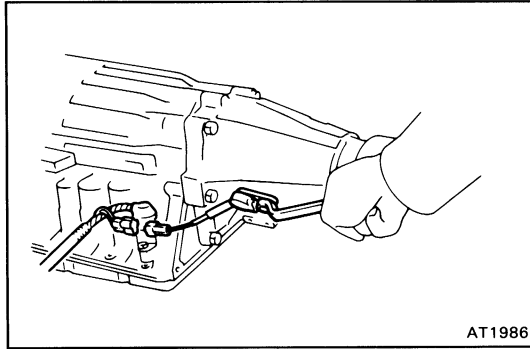
**43. INSTALL SPEED SENSOR**

(a) Coat a new O-ring with ATF and install it to the speed sensor.

(b) Install the speed sensor. Install and torque the bolt.

**Torque:** 160 kg-cm (12 ft-lb, 16 N·m)

(c) Connect the connector.

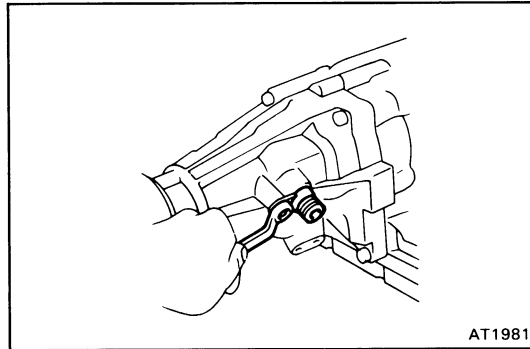
**44. INSTALL SPEEDOMETER DRIVEN GEAR**

(a) Coat a new O-ring with ATF and install it to the speedometer driven gear.

(b) Install the speedometer driven gear. Install and torque the bolt.

**Torque:** 160 kg-cm (12 ft-lb, 16 N·m)

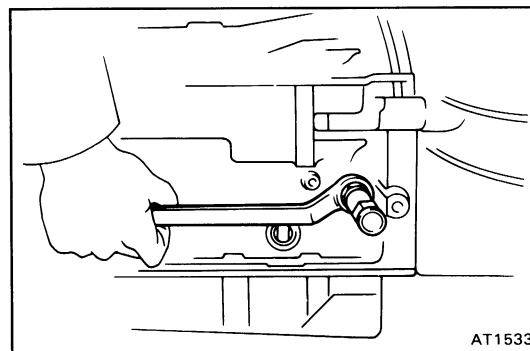
**45. INSTALL UNIONS**

(a) Coat new two O-rings with ATF and install them to each union.

(b) Install the front union.

**Torque:** 300 kg-cm (22 ft-lb, 29 N·m)

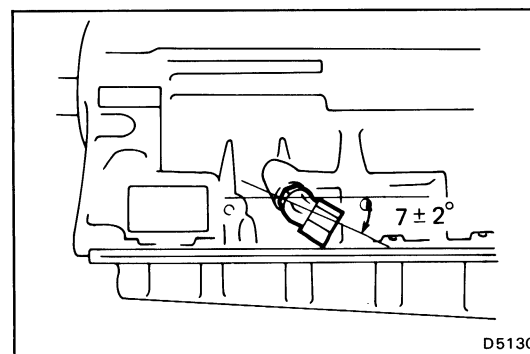

(c) Install the rear union as shown in the figure.

**Torque:** 300 kg-cm (22 ft-lb, 29 N·m)

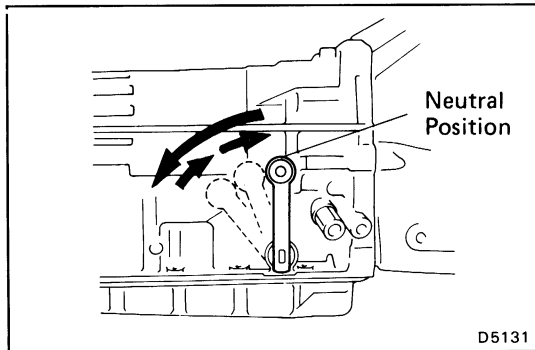

**46. INSTALL NEUTRAL START SWITCH**

- (a) Using the control shaft lever, fully turn the manual lever shaft back and return two notches. it is now in neutral.
- (b) Insert the neutral start switch onto the manual valve lever shaft and temporarily tighten the adjusting bolt.

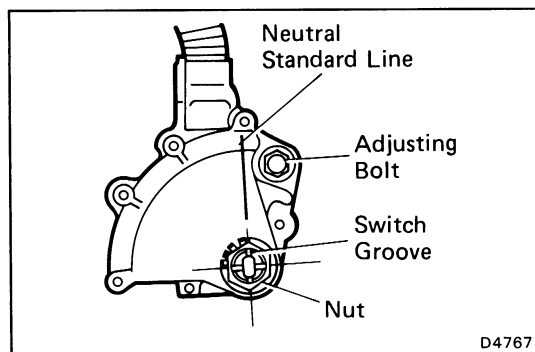

- (c) Install the grommet and a new lock washer. Install and torque the nut.

**Torque: 70 kg-cm (61 in.-lb, 6.9 N·m)**

- (d) Align the neutral standard line and the switch groove, and tighten the adjusting bolt.

**Torque: 130 kg-cm (9 ft-lb, 13 N·m)**

- (e) Bend the tabs of the lock washer.

**HINT:** Bend at least two of the lock washer tabs.

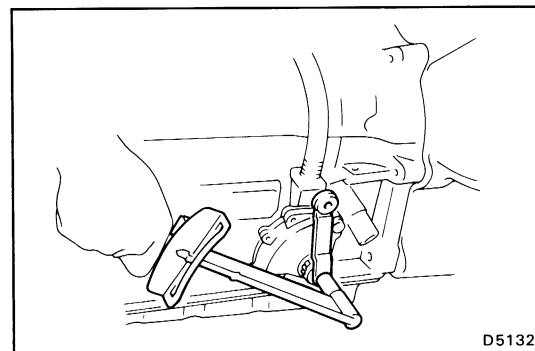

**47. INSTALL CONTROL SHAFT LEVER**

**Torque: 160 kg-cm (12 ft-lb, 16 N·m)**

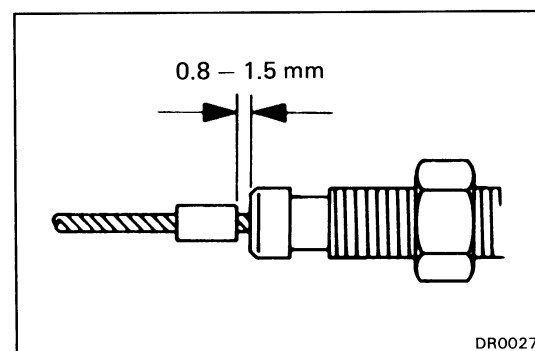

**48. IF THROTTLE CABLE IS NEW, STAKE STOPPER ON INNER CABLE**

**HINT:** New cable does not have a cable stopper staked.

- (a) Bend the cable so there is a radius of about 200 mm (7.78 in.).
- (b) Pull the inner cable lightly until a slight resistance is felt, and hold it.
- (c) Stake the stopper, 0.8 – 1.5 mm (0.031 – 0.059 in.) from the end of outer cable.

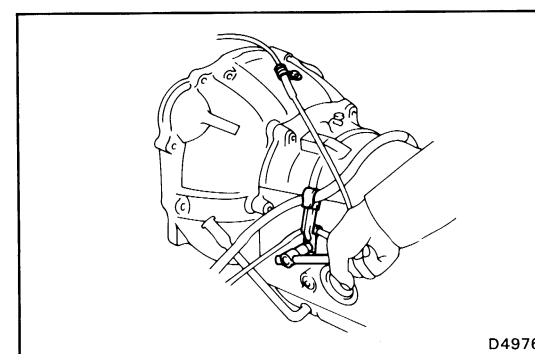

**49. INSTALL WIRE HARNESS CLAMP AND THROTTLE CABLE CLAMP**

# SHIFT LOCK SYSTEM COMPONENT AND CIRCUIT

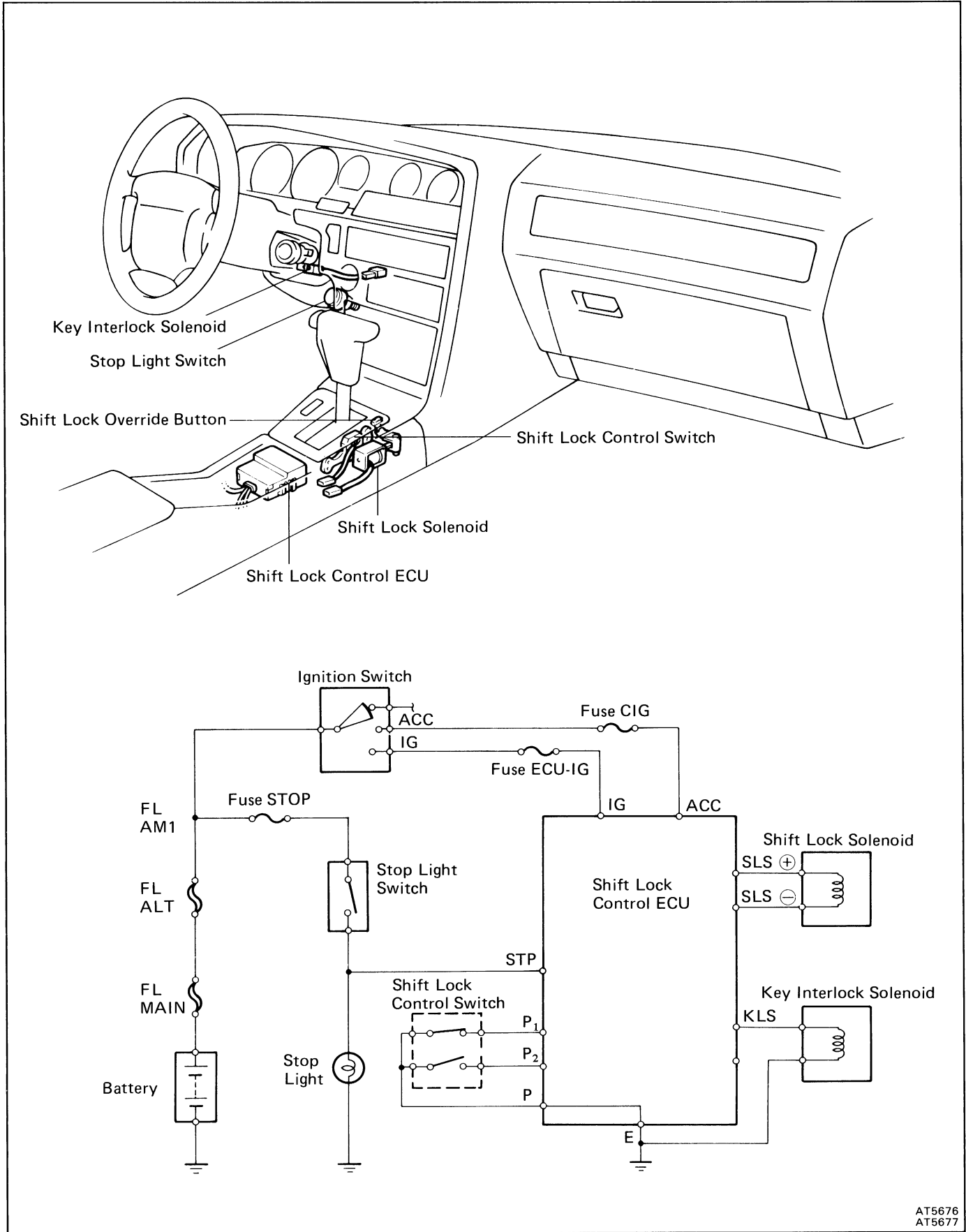

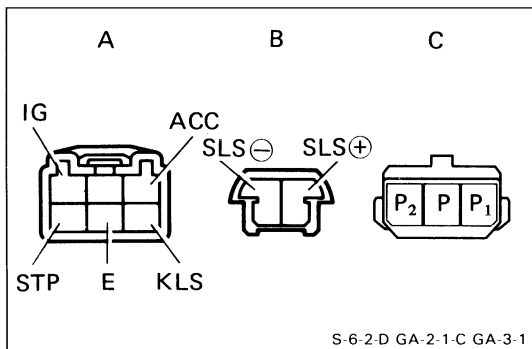

## INSPECTION OF ELECTRIC CONTROL COMPONENTS

### 1. INSPECT SHIFT LOCK CONTROL ECU

Using a voltmeter, measure the voltage at each terminals.

Connector	Terminal	Measuring Condition	Voltage (V)	
A	ACC – E	IG SW ACC position	10 – 14	
	IG – E	IG SW ON position	10 – 14	
	STP – E	Depress brake pedal	10 – 14	
	KLS – E	①	IG SW ACC position and P range	0
②		P → R, N, D, 2, L ranges	10 – 14	
③		↑ (Approx. after one second)	6 – 9	
B	SLS+ – SLS-	①	IG SW ON position and P range	0
		②	Depress brake pedal	8.5 – 13.5
		③	↑ (Approx. after 20 seconds)	5.5 – 9.5
		④	P → R, N, D, 2, L ranges or release brake pedal	0
C	P <sub>1</sub> – P	①	IG SW ON, P range and depress brake pedal	0
		②	P → R, N, D, 2, L ranges	9 – 13.5
	P <sub>2</sub> – P	①	IG SW ACC position and P range	9 – 13.5
		②	P → R, N, D, 2, L ranges	0

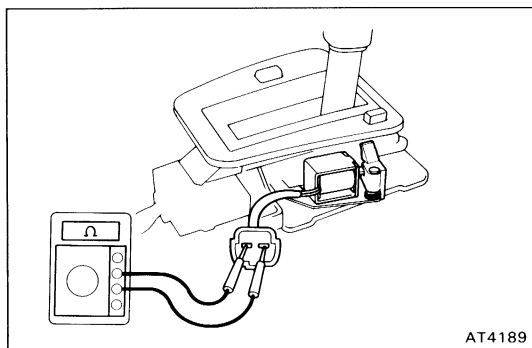

### 2. INSPECT SHIFT LOCK SOLENOID

- (a) Disconnect the solenoid connector.
- (b) Using an ohmmeter, measure the resistance between terminals.

**Standard resistance: 20 – 28 Ω**

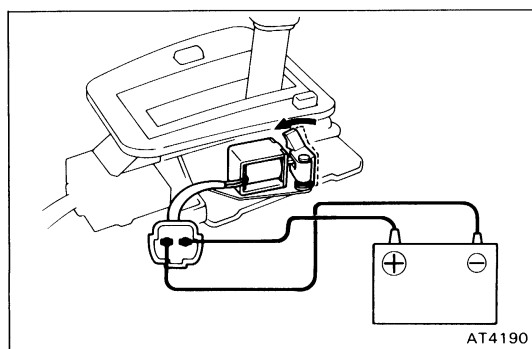

- (c) Apply the battery voltage between terminals. At this time, confirm that a solenoid operation.

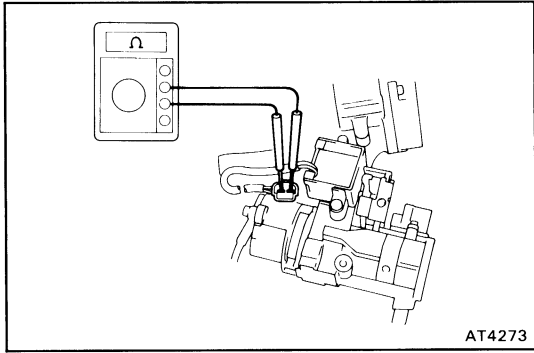

**3. INSPECT KEY INTERLOCK SOLENOID**

- (a) Disconnect the solenoid connector.
- (b) Using an ohmmeter, measure the resistance between terminals.

**Standard resistance: 12 – 17 Ω**

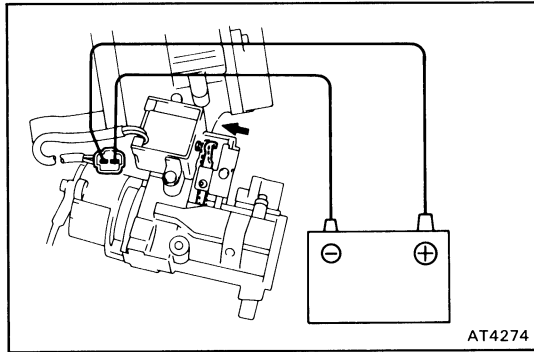

- (c) Apply the battery voltage between terminals. At this time, confirm that a solenoid operation.

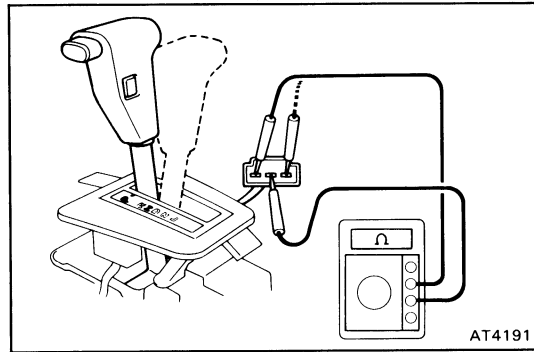

**4. INSPECT SHIFT LOCK CONTROL SWITCH**

Inspect that there is continuity between each terminals.

○—○ : Continuity

Shift Position \ Terminal	P	P <sub>1</sub>	P <sub>2</sub>
P range (Release button is not pushed)	○—○	○—○	
R, N, D, 2, L ranges	○—○		○—○