PROPELLER SHAFT

	Page
PRECAUTIONS	PR-2
TROUBLESHOOTING	PR-2
PROPELLER SHAFT	PR-3

PRECAUTIONS

Be careful not to grip the propeller shaft tube too tightly in the vise as this will cause deformation.

TROUBLESHOOTING

Problem	Possible cause	Remedy	Page
Noise	Sleeve yoke spline worn	Replace sleeve yoke	PR-5
	Center bearing worn	Replace center bearing	PR-4
	Spider bearing worn or stuck	Replace spider bearing	PR-5
Vibration	Propeller shaft runout	Replace propeller shaft	PR-4
	Propeller shaft imbalance	Balance propeller shaft	
	Transmission extension housing bushing worn	Replace extension housing	MT-11, 51
	Sleeve yoke spline stuck	Replace sleeve yoke	PR-5

PROPELLER SHAFT COMPONENTS

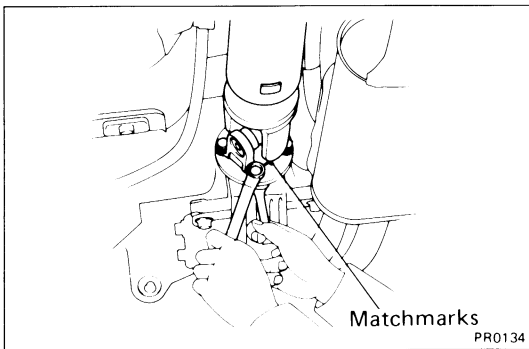
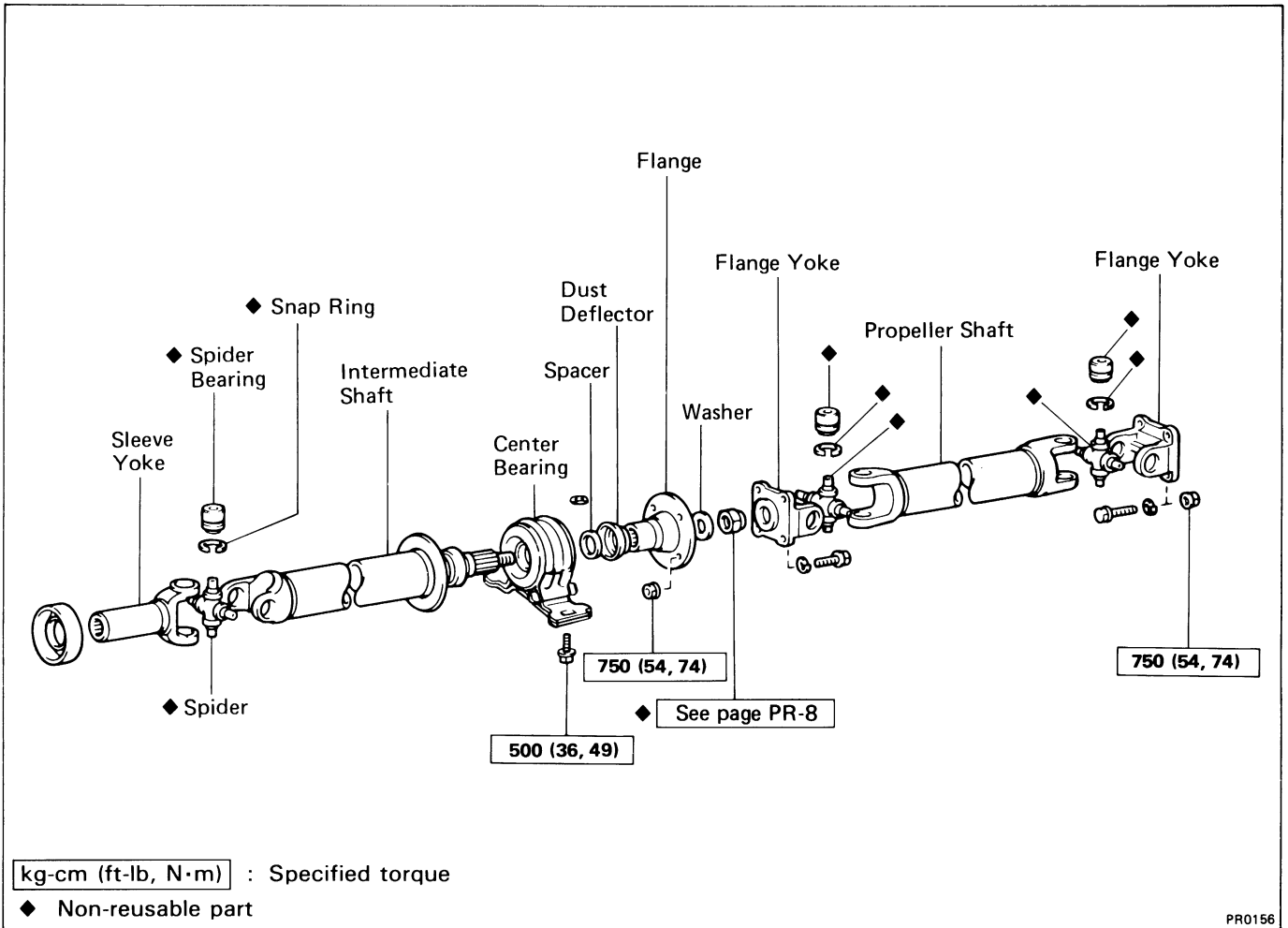

REMOVAL OF PROPELLER SHAFT

1. DISCONNECT PROPELLER SHAFT FROM DIFFERENTIAL

- (a) Place the matchmarks on the both flanges.
- (b) Remove the four bolts, washers and nuts.

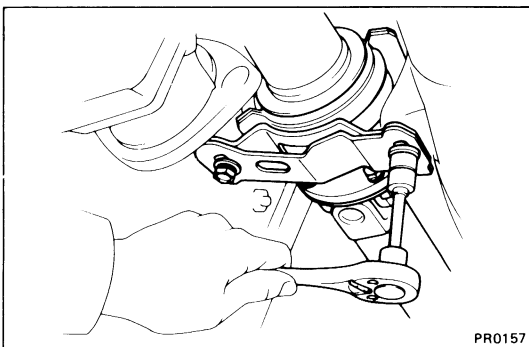

2. REMOVE CENTER SUPPORT BEARING FROM BODY

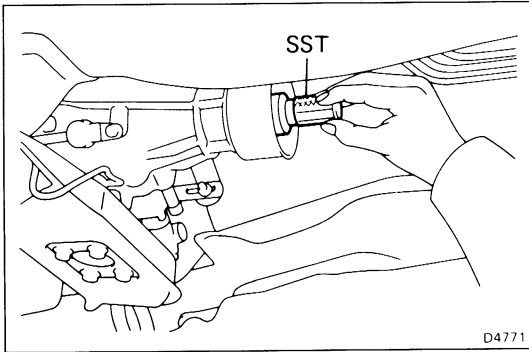

- 3. REMOVE PROPELLER SHAFT FROM TRANSMISSION**
- Pull the yoke from the transmission.
 - Insert SST in the transmission to prevent oil leakage.
- SST 09325-40010 (for A/T and R154 M/T)
09325-20010 (for W58 M/T)

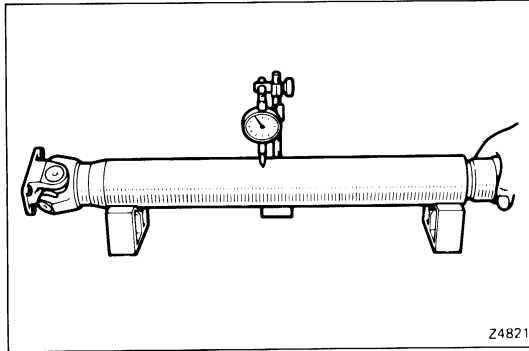

INSPECTION OF PROPELLER SHAFT

- 1. INSPECT PROPELLER AND INTERMEDIATE SHAFTS RUNOUT**

If shaft runout is greater than maximum, replace the shaft.

Maximum runout: 0.8 mm (0.031 in.)

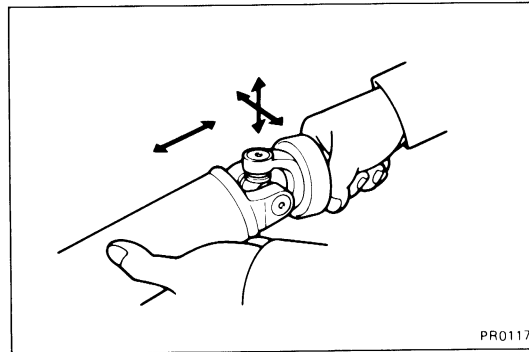

- 2. INSPECT SPIDER BEARINGS**

Check the spider bearing axial play by turning the yoke or flange while holding the shaft tightly.

Bearing axial play: Less than 0.05 mm (0.0020 in.)

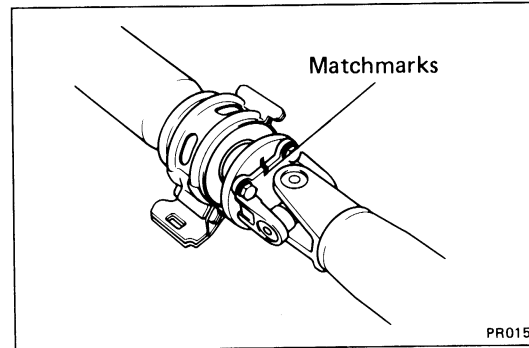

DISASSEMBLY OF PROPELLER SHAFT

- 1. SEPARATE PROPELLER SHAFT AND INTERMEDIATE SHAFT**

- Place the matchmarks on the both flanges.
- Remove the four bolts, washers and nuts.

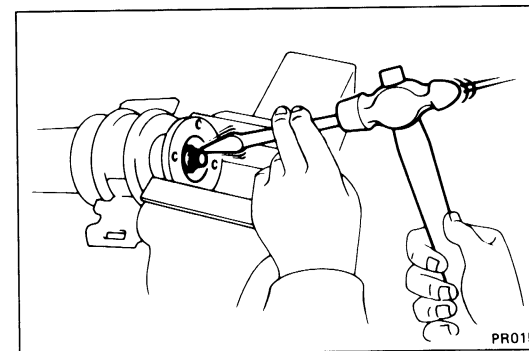

- 2. REMOVE CENTER SUPPORT BEARING FROM INTERMEDIATE SHAFT**

- Using a hammer and chisel, loosen the staked part of the nut.

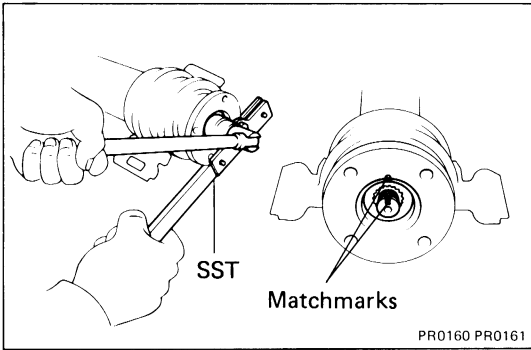

- (b) Using SST to hold the flange, remove the nut.
SST 09330-00021
- (c) Place the matchmarks on the flange and shaft.

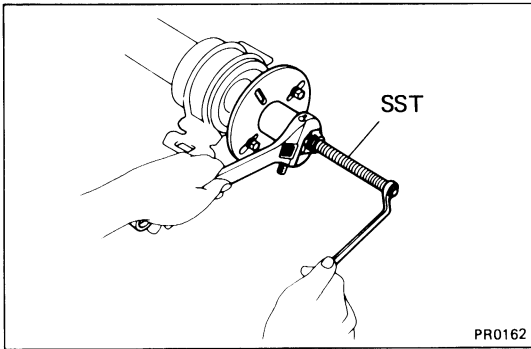

- (d) Using SST, remove the flange from the intermediate shaft.
SST 09557-22022
- (e) Remove the center support bearing from the intermediate shaft.

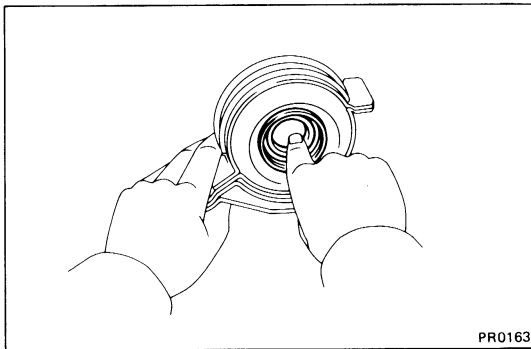

3. INSPECT CENTER SUPPORT BEARING

- Check that the bearing turns freely.
- If the bearing is damaged, worn, or does not turn freely, replace it.

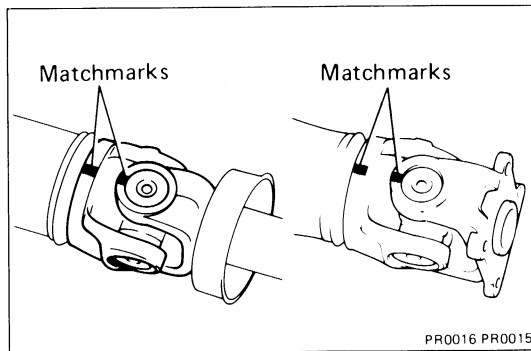

REPLACEMENT OF SPIDER BEARING

1. PLACE MATCHMARKS ON SHAFT AND FLANGE OR YOKE

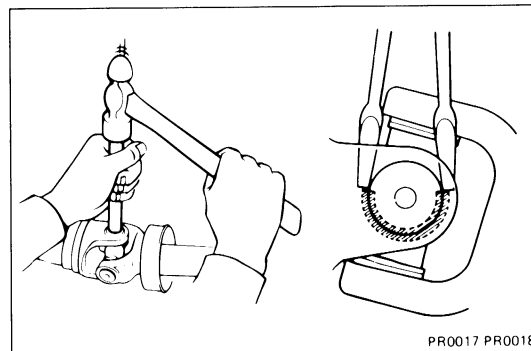

2. REMOVE SNAP RINGS

- (a) Slightly tap in the bearing outer races.
- (b) Using two screwdrivers, remove the four snap rings from the grooves.

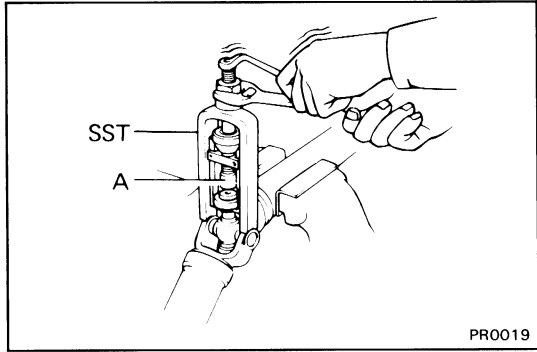

3. REMOVE SPIDER BEARINGS

(a) Using SST, push out the bearing from the propeller shaft.

SST 09332-25010

HINT: Sufficiently raise the part indicated by A so that it does not come into contact with the bearing.

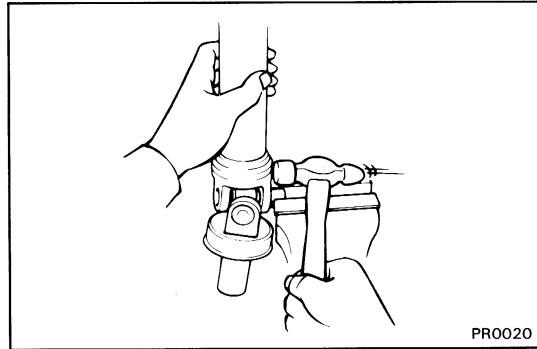

(b) Clamp the bearing outer race in a vise and tap off the propeller shaft with a hammer.

HINT: Remove the bearing on the opposite side in the same procedure.

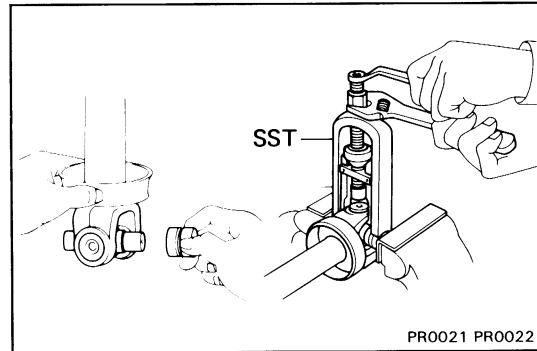

(c) Install the two removed bearing outer races to the spider.

(d) Using SST, push out the bearing from the yoke.

SST 09332-25010

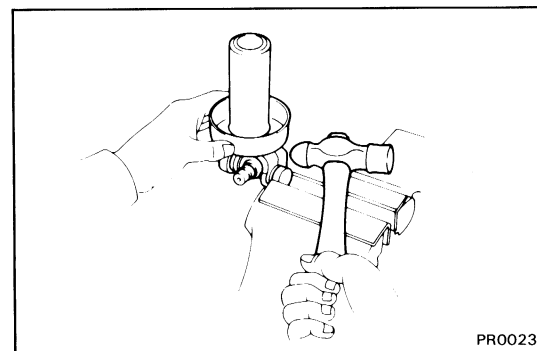

(e) Clamp the bearing outer race in a vise and tap off the yoke with a hammer.

HINT: Remove the bearing on the opposite side in the same procedure.

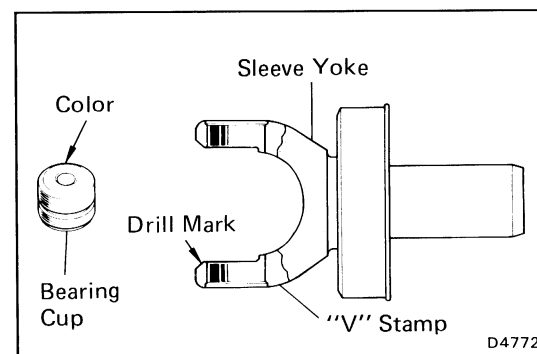

4. SELECT THE SPIDER BEARING

Select the bearing according to whether or not there is a drill mark and "V" stamp on the yoke section.

Sleeve Yoke	Bearing
With marks (drill mark, "V" stamp)	With color mark (Red)
No marks	No color mark

HINT: There are two "V" stamps on the flange yoke (on outer surface of yoke section).

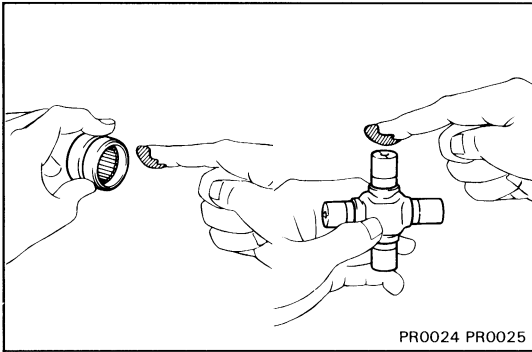

5. INSTALL SPIDER BEARINGS

(a) Apply MP grease to the spider and bearings.

HINT: Be careful not to apply too much grease.

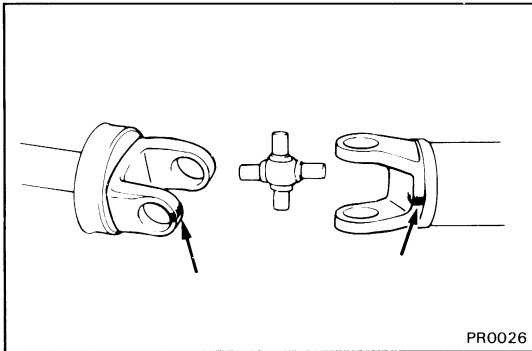

(b) Align the matchmarks on the yoke and shaft.

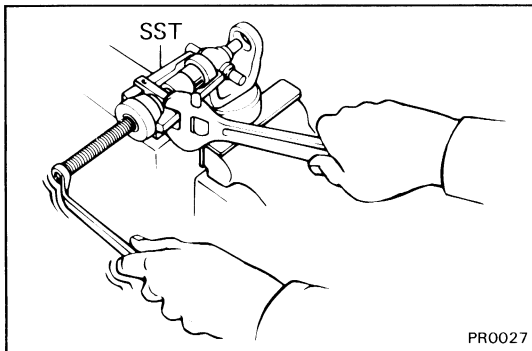

(c) Fit a new spider into the yoke.

(d) Using SST, install new bearings on the spider.

SST 09332-25010

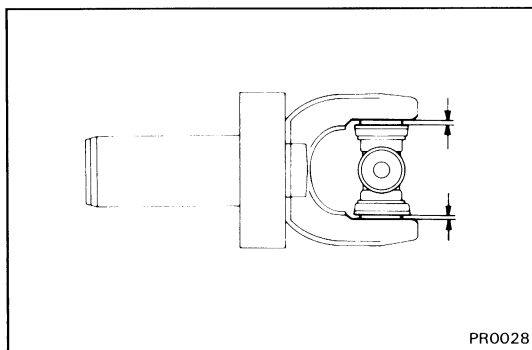

(e) Using SST, adjust both bearings so that the snap ring grooves are at maximum and equal widths.

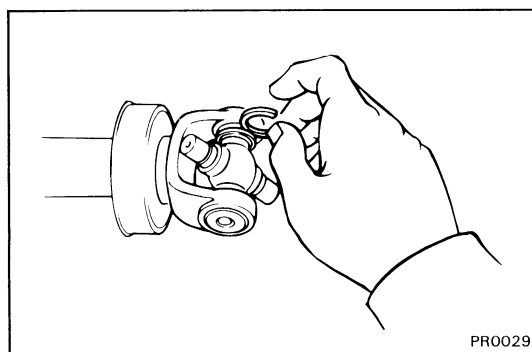

6. INSTALL SNAP RINGS

(a) Install two snap rings of equal thickness which will allow 0 — 0.05 mm (0 — 0.0020 in.) axial play.

HINT: Do not reuse the snap rings.

Mark	Color	Thickness	mm (in.)
1	—	2.100 — 2.150	(0.0827 — 0.0846)
2	—	2.150 — 2.200	(0.0846 — 0.0866)
3	—	2.200 — 2.250	(0.0866 — 0.0886)
—	Brown	2.250 — 2.300	(0.0886 — 0.0906)
—	Blue	2.300 — 2.350	(0.0906 — 0.0925)
6	—	2.350 — 2.400	(0.0925 — 0.0945)
7	—	2.400 — 2.450	(0.0945 — 0.0965)
8	—	2.450 — 2.500	(0.0965 — 0.0984)

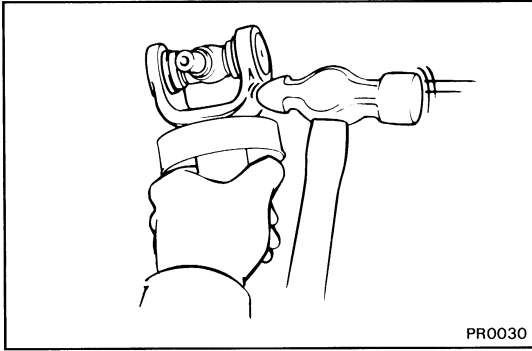

- (b) Using a hammer, tap the yoke until there is no clearance between the bearing outer race and snap ring.

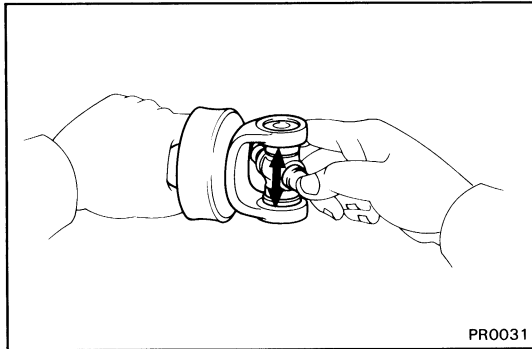

7. CHECK SPIDER BEARING

- (a) Check that the spider bearing moves smoothly.
 (b) Check the spider bearing axial play.

Bearing axial play: Less than 0.05 mm (0.0020 in.)

HINT: Install new spider bearings on the shaft side in the procedure described above.

ASSEMBLY OF PROPELLER SHAFT

HINT: If replacing either the center flange or intermediate shaft, reassemble them so that the sleeve yoke and propeller shaft yoke are facing in the same direction shown in the figure below.

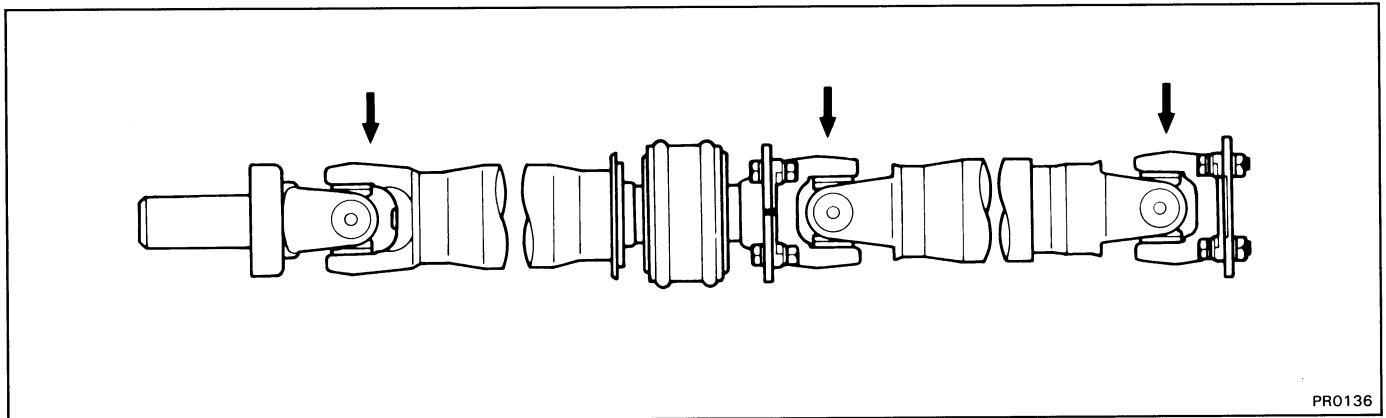

PR0136

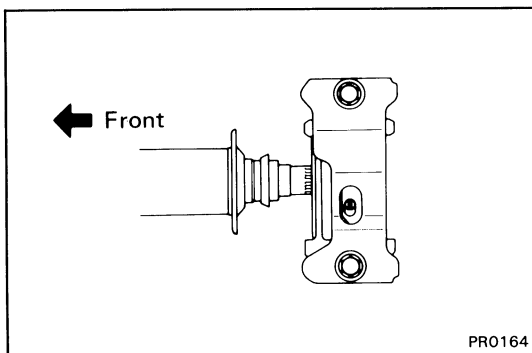

1. INSTALL CENTER SUPPORT BEARING ON INTERMEDIATE SHAFT

HINT: Install the center support bearing with the cutout toward the rear.

PR0164

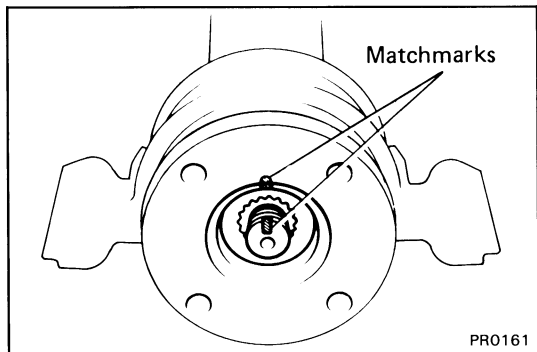

2. INSTALL FLANGE ON INTERMEDIATE SHAFT

- (a) Coat the splines of the intermediate shaft with MP grease.
- (b) Align the matchmarks on the flange and shaft and place the flange on the shaft.

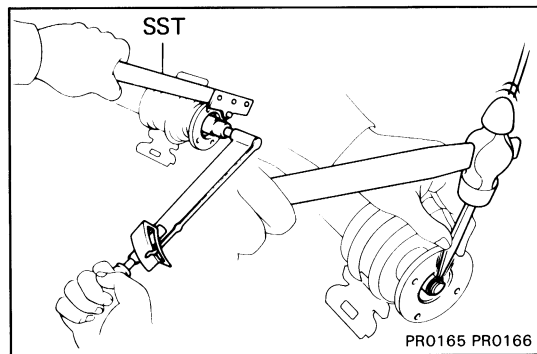

- (c) Using SST to hold the flange, press the bearing into position by tightening down a new nut.

SST 09330-00021

Torque: 1,850 kg-cm (134 ft-lb, 181 N·m)

- (d) Loosen the nut.
- (e) Torque the nut again.

Torque: 700 kg-cm (51 ft-lb, 69 N·m)

- (f) Using a hammer and punch, stake the nut.

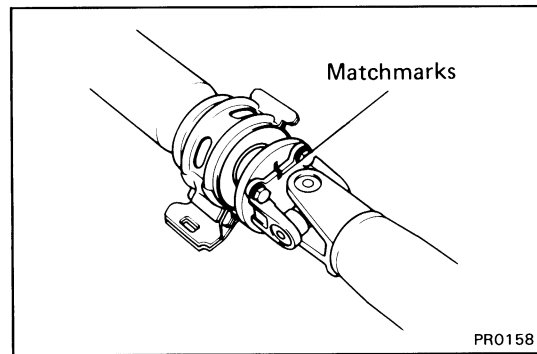

3. INSTALL PROPELLER SHAFT

Align the matchmarks on the flanges and connect the propeller shaft and intermediate shaft with the four bolts, washers and nuts.

Torque: 750 kg-cm (54 ft-lb, 74 N·m)

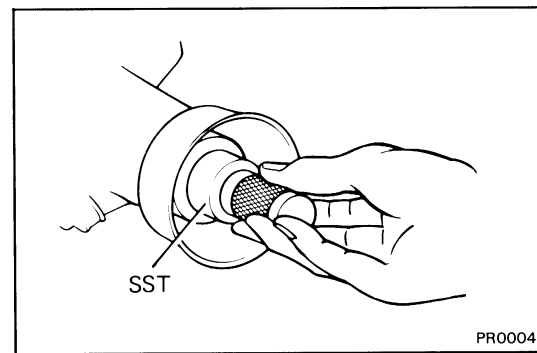

INSTALLATION OF PROPELLER SHAFT

1. INSERT YOKE IN TRANSMISSION

- (a) Remove SST.
- SST 09325-40010 (for A/T and R154 M/T)
09325-20010 (for W58 M/T)
- (b) Insert the yoke into the transmission.

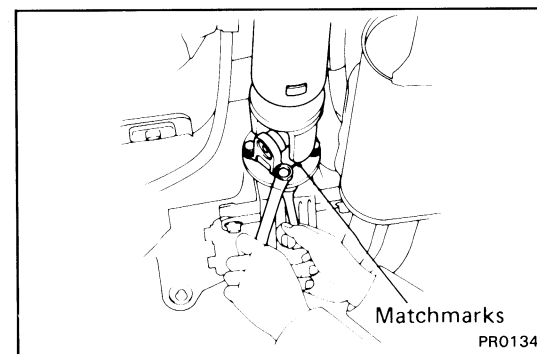

2. CONNECT PROPELLER SHAFT TO DIFFERENTIAL

- (a) Align the matchmarks on the flanges and connect the propeller shaft with the four bolts, washers and nuts.
- (b) Torque the bolts and nuts.

Torque: 750 kg-cm (54 ft-lb, 74 N·m)

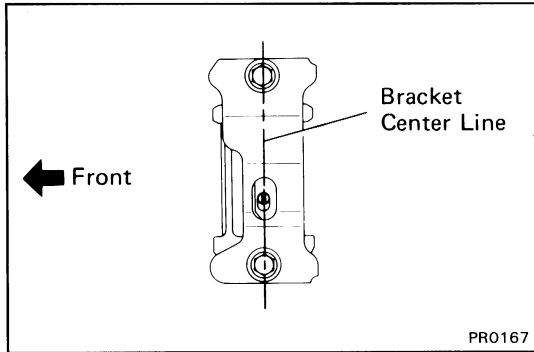

3. INSTALL CENTER SUPPORT BEARING TO BODY

- (a) Install the center support bearing to the body with the two mount bolts finger tight.
- (b) Check that the bearing bracket is at right angle to the propeller shaft. Adjust the bracket if necessary.
- (c) Check that the center line of the center bearing is set to the center line of the bracket when the vehicle is in a no-load condition. Adjust the center bearing if necessary.

- (d) Torque the bolts.

Torque: 500 kg-cm (36 ft-lb, 49 N·m)

