

AIR CONDITIONING SYSTEM

	Page
GENERAL INFORMATION	AC-2
AIR CONDITIONING SYSTEM CIRCUIT	AC-4
SYSTEM COMPONENTS	AC-8
GENERAL DESCRIPTION	AC-9
SPECIAL TOOLS AND EQUIPMENT	AC-14
TROUBLESHOOTING	AC-15
Checking of Refrigeration System with Manifold Gauge	AC-17
ON-VEHICLE INSPECTION	AC-20
REFRIGERATION SYSTEM	AC-21
Checking of Refrigerant Volume	AC-21
Installation of Manifold Gauge Set	AC-21
COMPRESSOR	AC-22
RECEIVER	AC-28
CONDENSER	AC-28
CONDENSER FAN MOTORS	AC-30
HEATER BLOWER RESISTOR	AC-30
RELAYS	AC-30
PRESSURE SWITCH	AC-32
WATER TEMPERATURE SWITCH	AC-32
COOLING UNIT	AC-33
Evaporator	AC-35
REFRIGERANT LINES	AC-36
THERMISTOR	AC-37
A/C CONTROL PANEL ASSEMBLY	AC-38
AMPLIFIERS	AC-40
SENSORS	AC-42
FUNCTIONAL TEST AND ADJUSTMENT	AC-43

GENERAL INFORMATION

ELECTRICAL PARTS

Before removing and inspecting the electrical parts, set the ignition switch to the LOCK position and disconnect the negative (—) terminal cable from the battery.

CAUTION: Work must not be started until after at least 20 seconds or longer from the time the negative (—) terminal cable is disconnected.

SRS AIRBAG SYSTEM

Failure to carry out service operations in the correct sequence could cause the airbag system to deploy, possibly leading to a serious accident.

When removal or installation of the parts and the yellow wire harness and connector for the airbag is necessary, refer to the precautionary notices in the AB section before performing the operation.

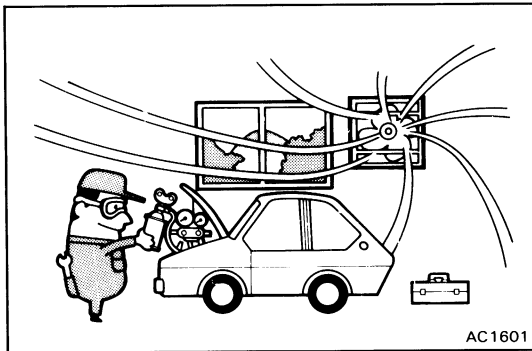

AC1601



AC1602

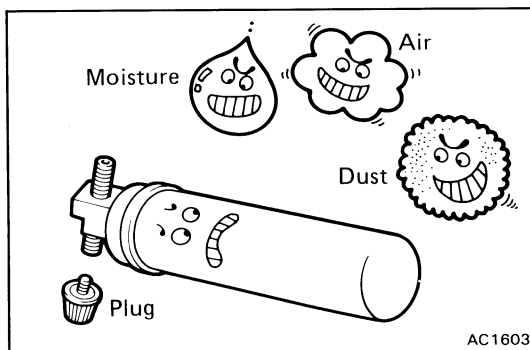

AC1603

COOLING SYSTEM

1. WHEN HANDLING REFRIGERANT (R-12), FOLLOWING PRECAUTIONS MUST BE OBSERVED;

- (a) Do not handle refrigerant in an enclosed area or near an open flame.
- (b) Always wear eye protection.
- (c) Be careful that liquid refrigerant does not get in your eyes or on your skin.

If liquid refrigerant gets in your eyes or on your skin;

- Do not rub.
- Wash the area with lots of cool water.
- Apply clean petroleum jelly to the skin.
- Go immediately to a physician or hospital for professional treatment.
- Do not attempt to treat yourself.

2. WHEN REPLACING PARTS IN REFRIGERANT LINE;

- (a) Discharge the refrigerant in the line slowly before replacement.
- (b) Insert a plug immediately in disconnected parts to prevent the entry of moisture and dust.
- (c) Do not leave a new condenser or receiver, etc., lying around with the plug removed.

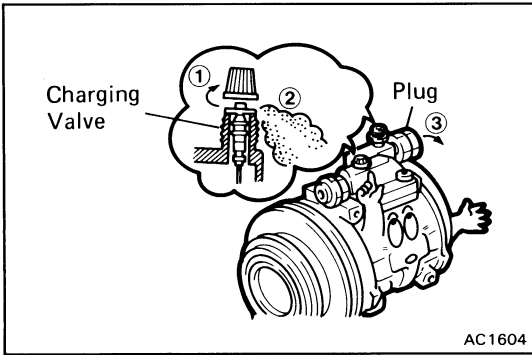

(d) Discharge the refrigerant from the charging valve before installing a new compressor.

If the refrigerant is not discharged first, compressor oil will spray out with the refrigerant gas when the plug is removed.

(e) Do not use a torch for tube bending or lengthening operations.

If tubes are heated with a torch, a layer of oxidation forms inside the tube, causing the same kind of trouble as an accumulation of dust.

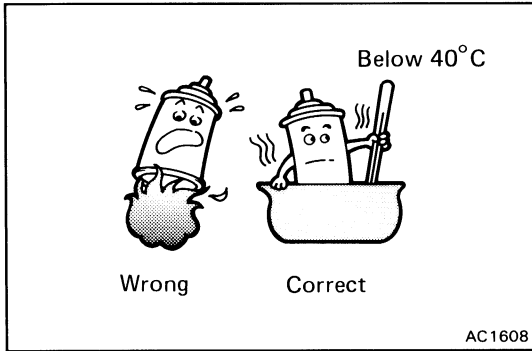

3. WHEN HANDLING REFRIGERANT CONTAINER (SERVICE CAN);

(a) The container must never be heated.

(b) Containers must be kept below 40°C (104°F)

(c) If warming a service can with hot water, be careful that the valve on top of the service can is never immersed in the water, as the water may permeate the refrigerant cycle.

(d) Empty service cans must never be re-used.

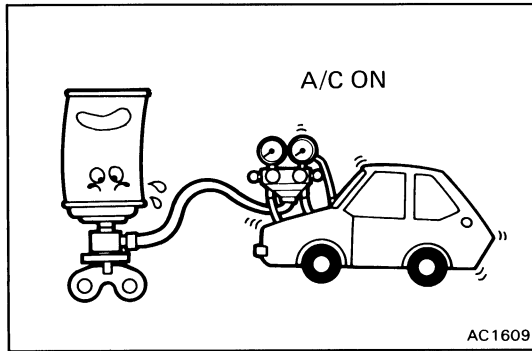

4. WHEN A/C IS ON AND REFRIGERANT GAS IS BEING REPLENISHED;

(a) If there is not enough refrigerant gas in the refrigerant cycle, oil lubrication will be insufficient and compressor burnout may occur, so take care to avoid this.

(b) If the valve on the high pressure side is opened, refrigerant flows in the reverse direction and could cause the service can to rupture, so open and close the valve on the low pressure side only.

(c) If the service can is inverted and refrigerant is loaded in a liquid state, the liquid is compressed and causes the compressor to break down, so the refrigerant must be in a gaseous state.

(d) Be careful not to load too much refrigerant gas, as this causes trouble such as inadequate cooling, poor fuel economy, engine overheating, etc.

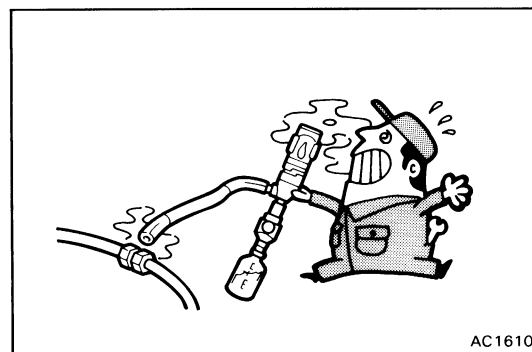

5. WHEN USING GAS-CYLINDER TYPE GAS LEAK TESTER;

(a) As a naked flame is used, first make sure that there are no flammable substances nearby before using it.

(b) Be careful, as a poisonous gas is produced when refrigerant gas comes in contact with heated parts.

AIR CONDITIONING SYSTEM CIRCUIT

7M-GTE Engine

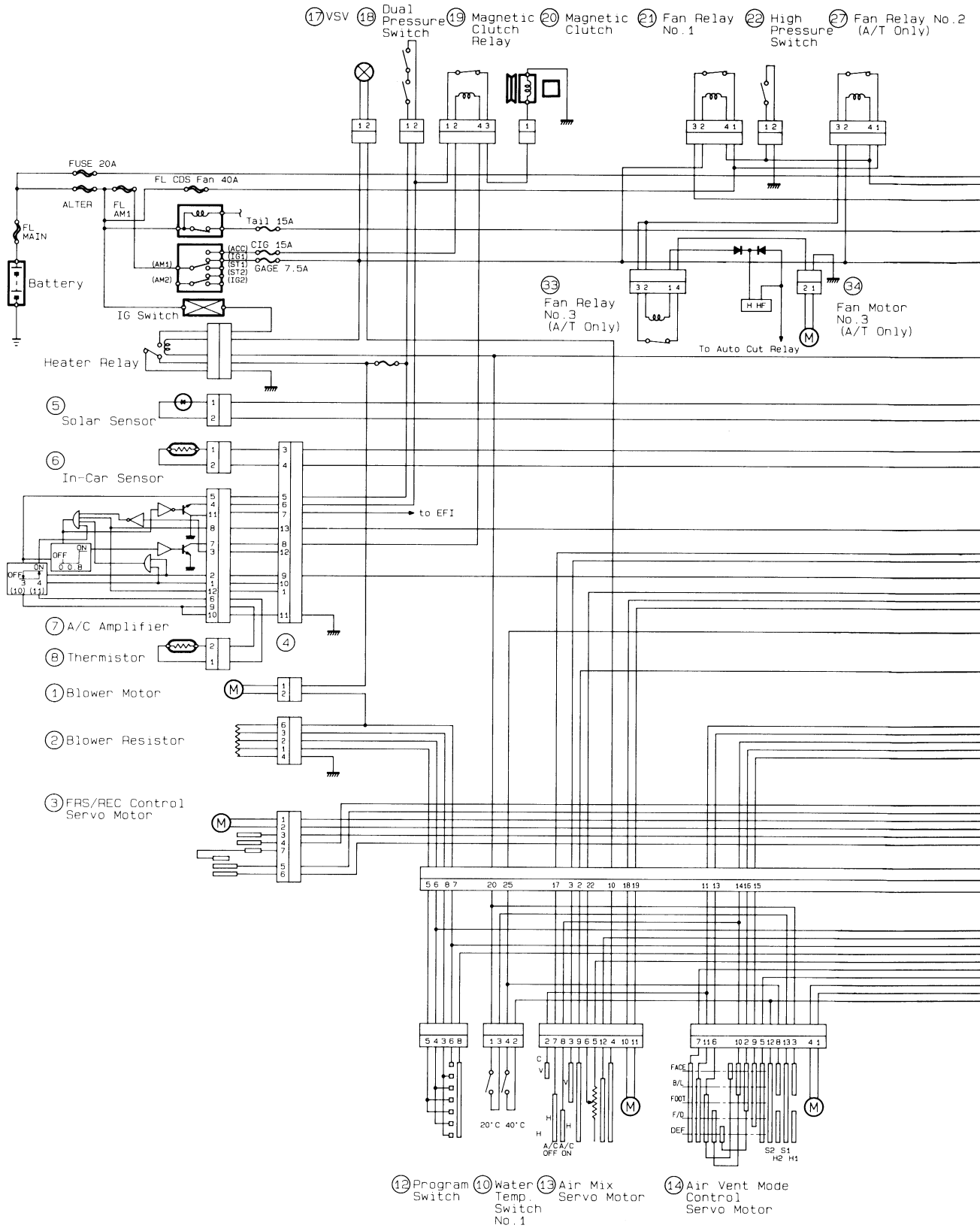

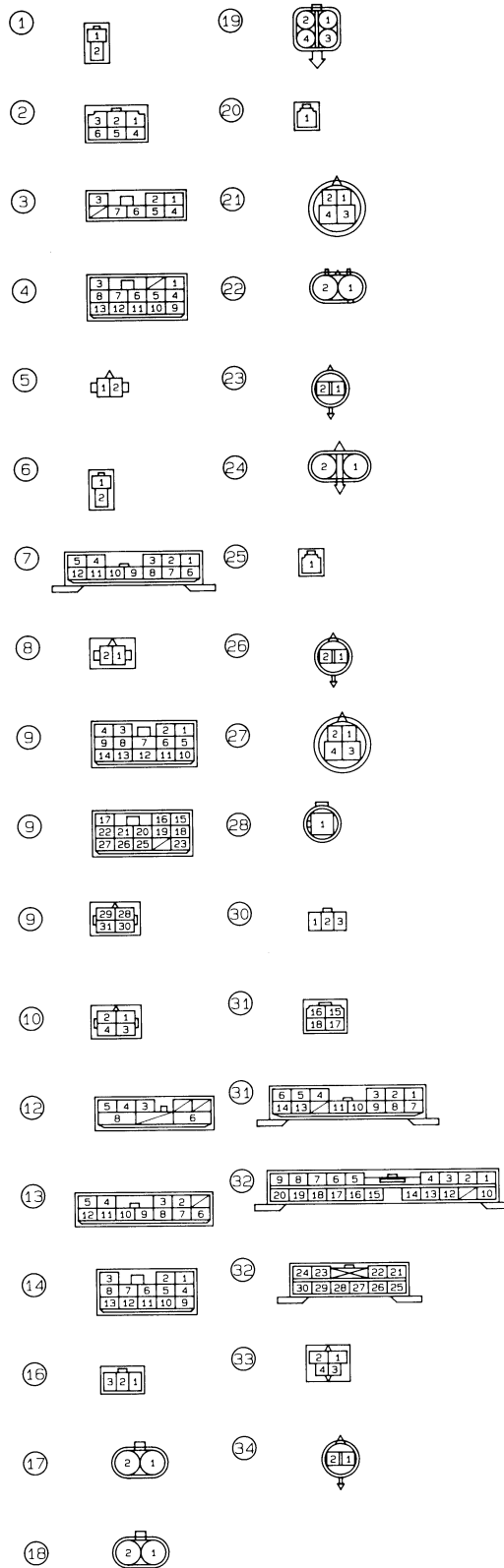
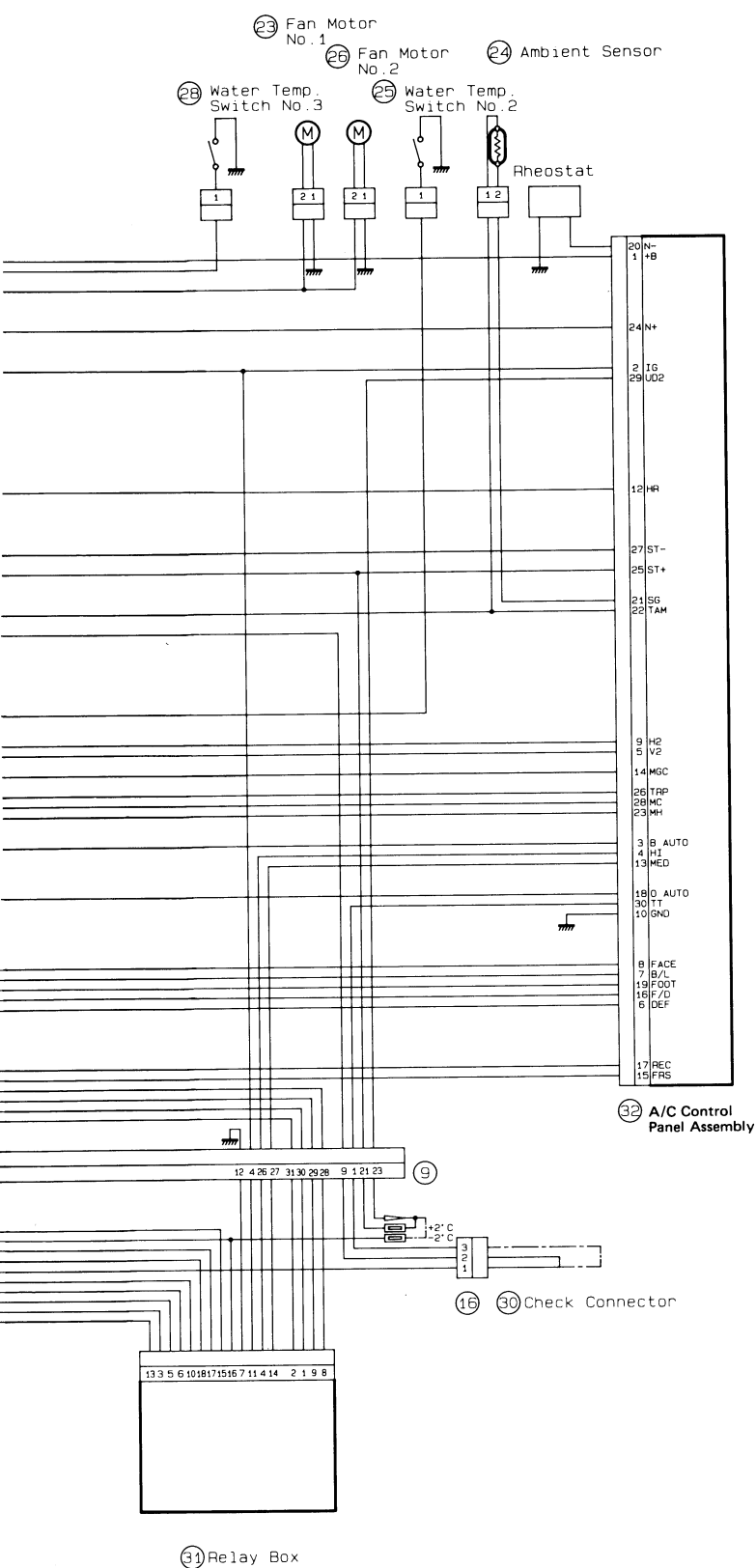

AIR CONDITIONING SYSTEM CIRCUIT (Cont'd)

7M-GE Engine

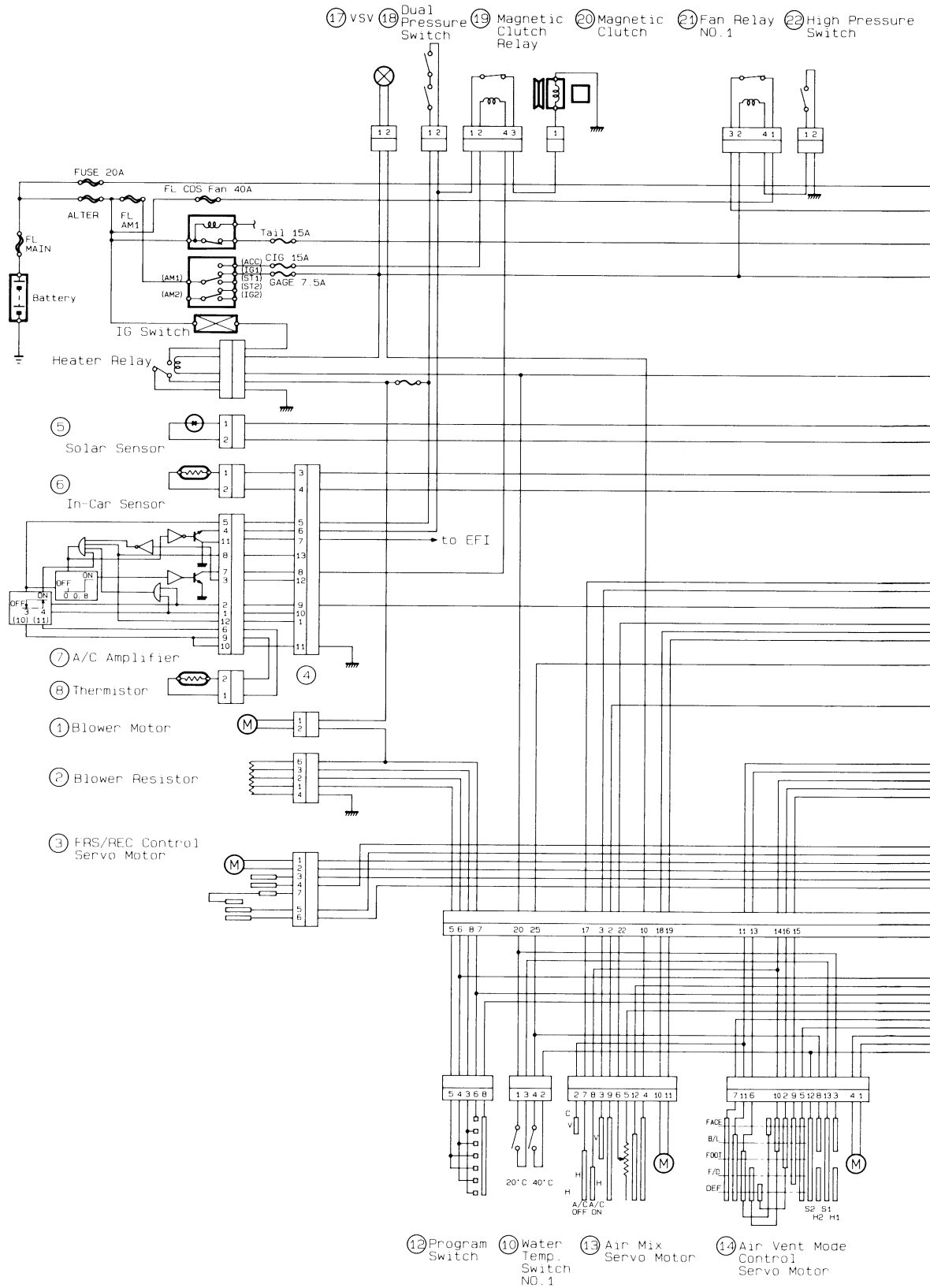

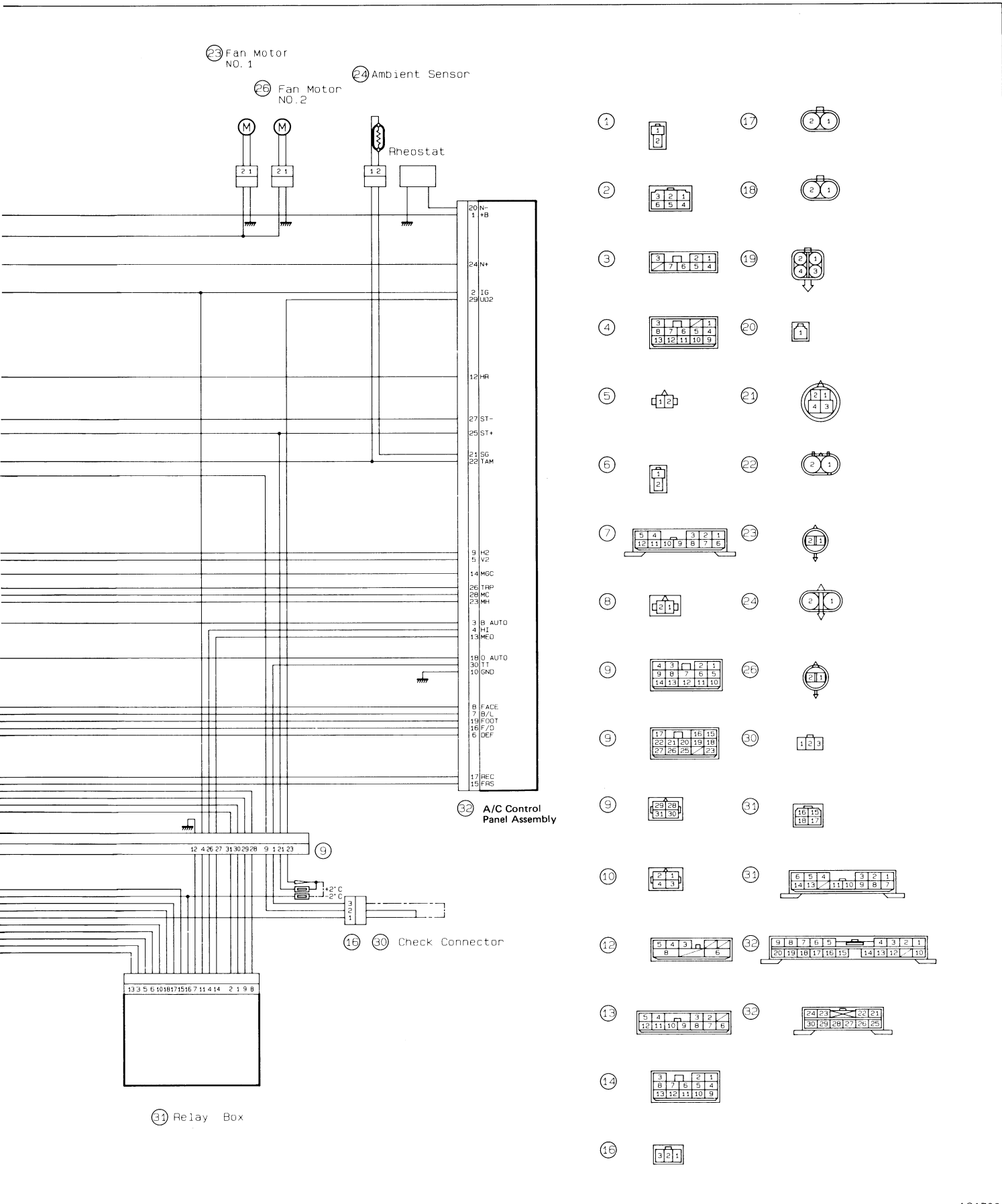

SYSTEM COMPONENTS

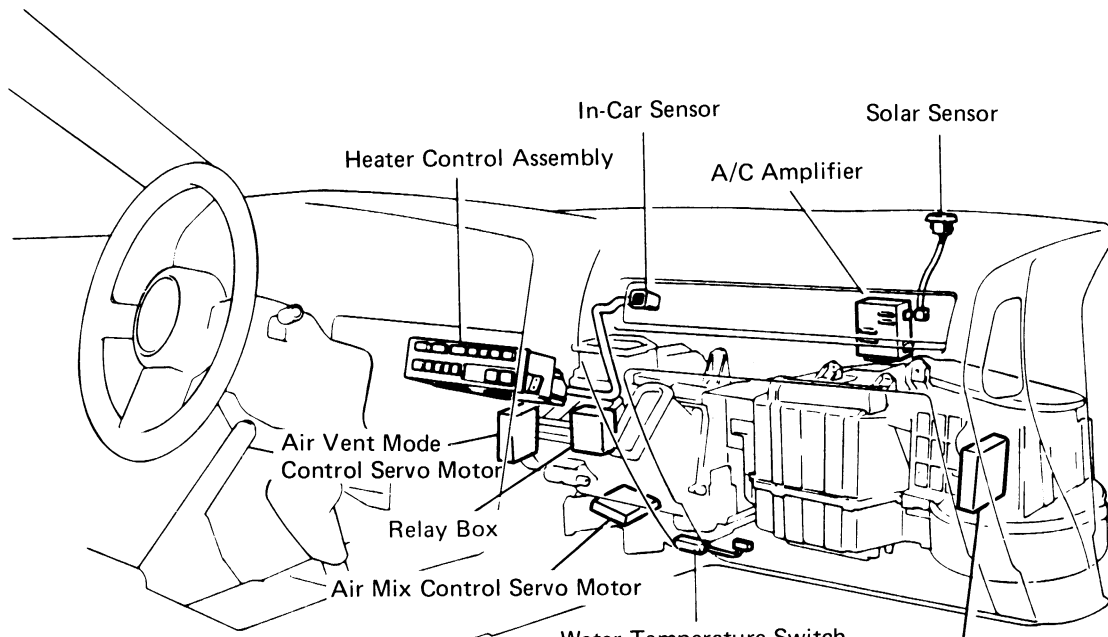
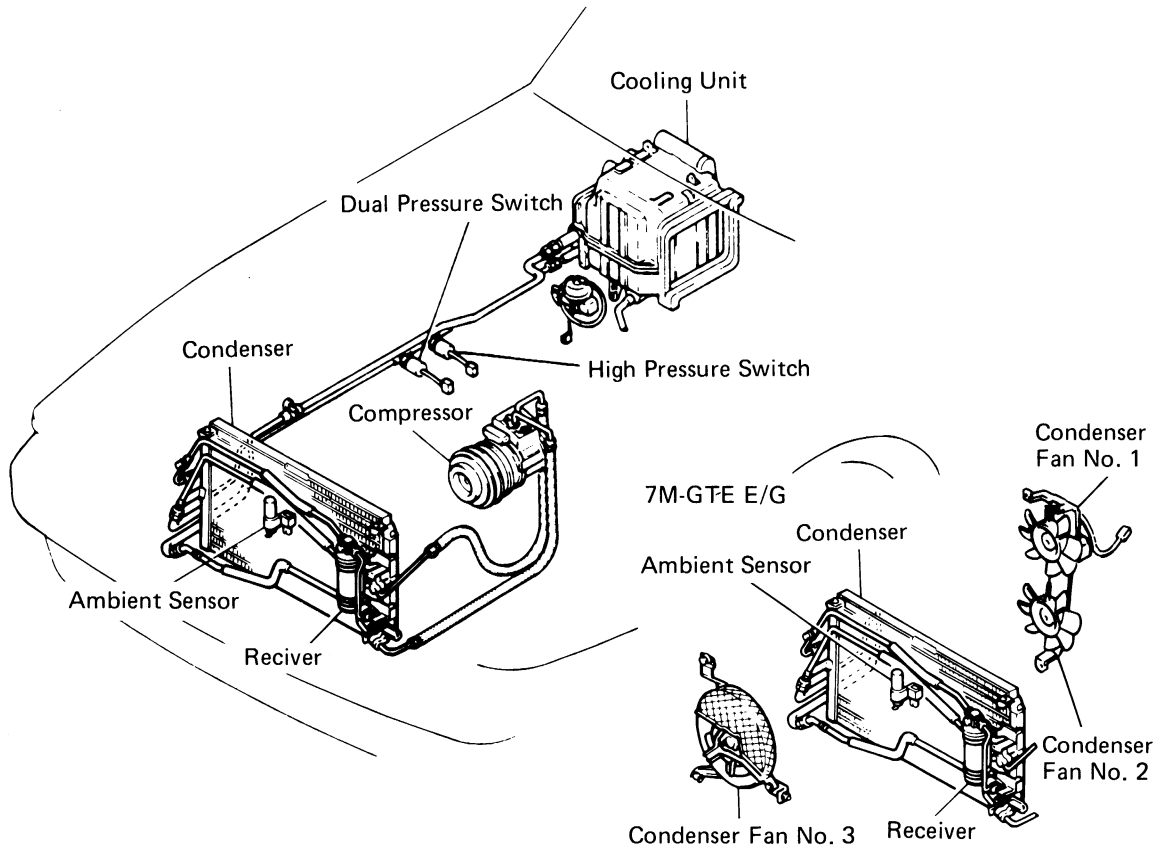

Specified torque: kg-cm (ft-lb, N-m)

RECIRC/FRESH Control Servo Motor

Fitting size	Torque	
0.31 in. Tube	135 (10, 13)	
0.50 in. Tube	225 (16, 22)	
0.62 in. Tube	325 (24, 32)	
Bolted Type	(For Compressor)	250 (18, 25)
	(For Condenser)	250 (18, 25)

GENERAL DESCRIPTION

REFRIGERATION CYCLE

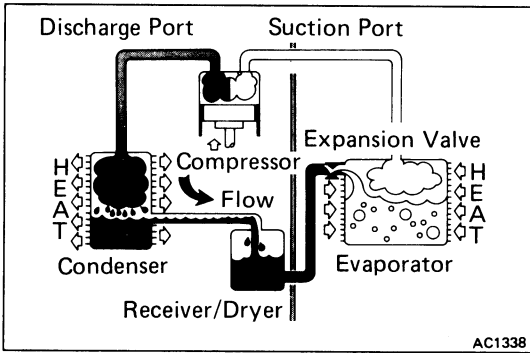

1. The compressor discharges high temperature and high pressure refrigerant containing the heat absorbed from the evaporator plus the heat created by the compressor in a discharge stroke.
2. This gaseous refrigerant flows into the condenser. In the condenser, the gaseous refrigerant condenses into liquid refrigerant.
3. This liquid refrigerant flows into the receiver which stores and filters the liquid refrigerant till the evaporator requires the refrigerant.

4. The liquid refrigerant is changed by the expansion valve into a low temperature, low pressure liquid and gaseous mixture.
5. This cold and foggy refrigerant flows to the evaporator. Vaporizing the liquid in the evaporator, the heat from the warm air stream passing through the evaporator core is transferred to the refrigerant. All the liquid is changed into the gaseous refrigerant in the evaporator and only heat-laden gaseous refrigerant is drawn into the compressor. Then the process is repeated again.

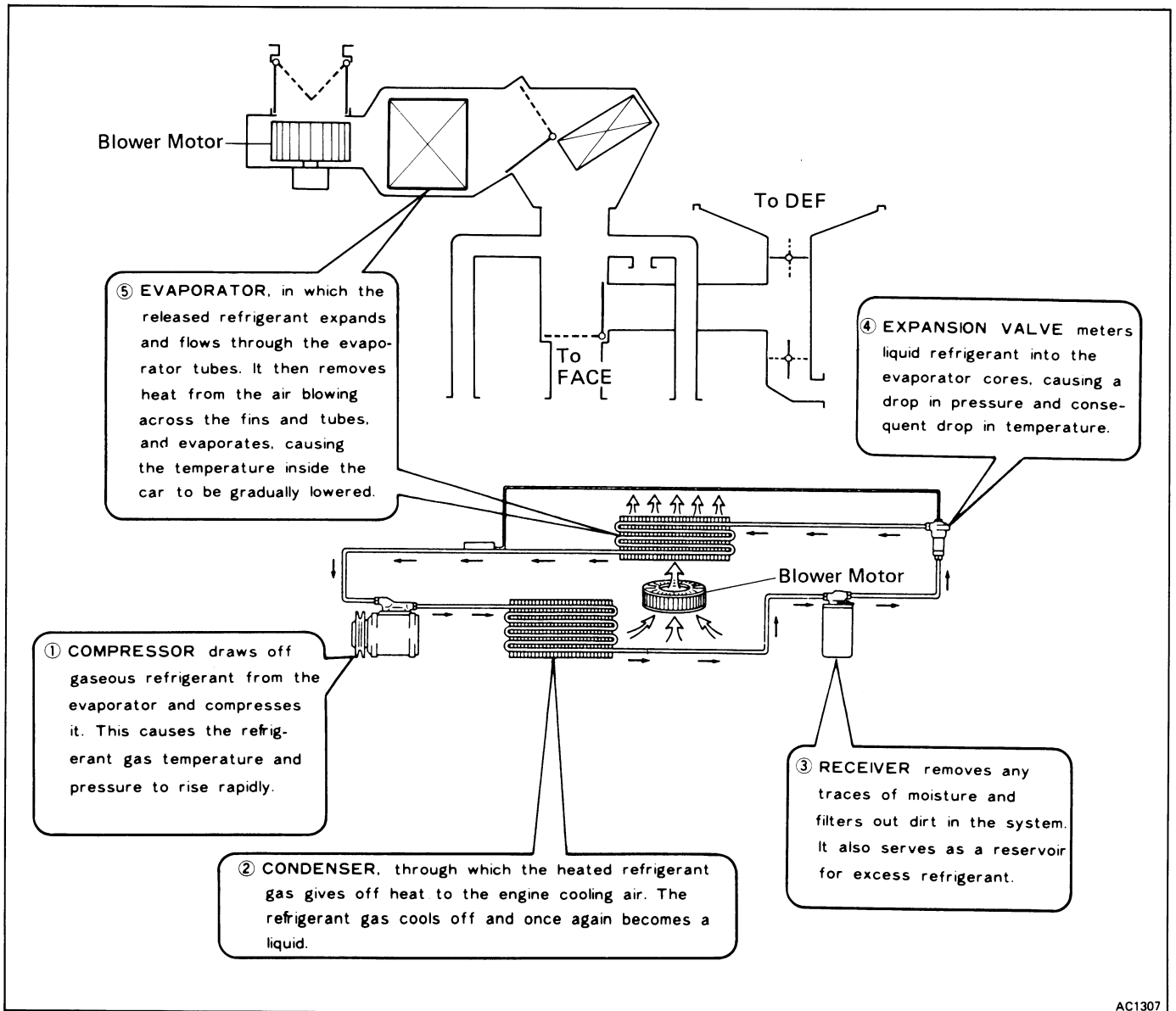

1. PRINCIPLE OF A/C ELECTRICAL CIRCUIT

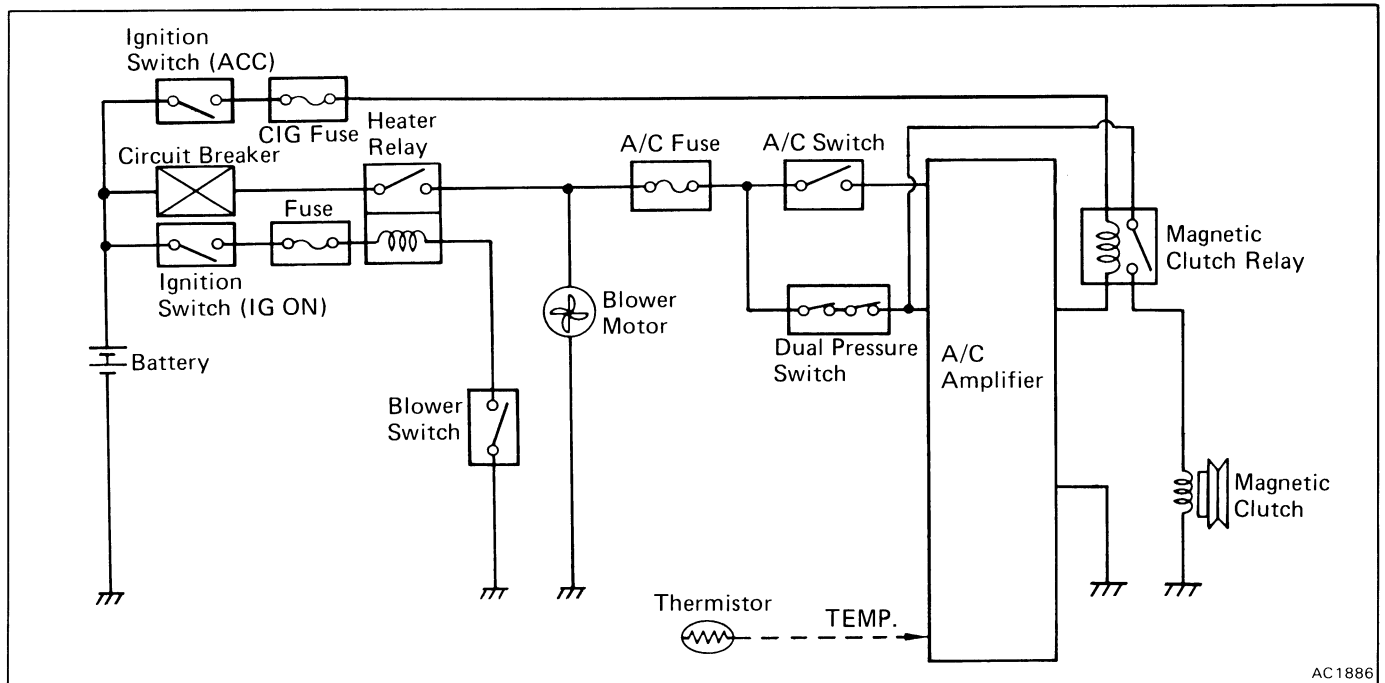

2. HOW IS THE MAGNETIC CLUTCH ENERGIZED?

The general process until the magnetic clutch is energized is shown below.

- ① Ignition Switch "ON"
- ② Blower Switch "ON" → Heater Relay "ON" (Blower Motor "RUN")
- ③ A/C Switch "ON" → A/C Amplifier "ON" (A/C Amp. Main Power Supply)
- ④ Dual Pressure Switch "ON":
Refrigerant Condition (2.1 kg/cm^2 (30 psi, 206 kPa) less than 2.7 kg/cm^2 (384 psi, 2,648 kPa))
- ⑤ Thermistor supplies temperature signal of evaporator to A/C amplifier.
- ⑥ VSV "ON" → E/G Idle-up
- ⑦ Magnetic Clutch Relay "ON"
- ⑧ Temperature Sensor "ON":
Temperature of Temperature Sensor is less than 180°C (356°F).
- ⑨ Magnetic Clutch "ON"
- ⑩ Revolution Detecting Sensor supplies RPM signal of compressor to A/C amplifier.

If compressor is not locked, magnetic clutch is continuously energized.

PRINCIPLE OF AUTOMATIC AIR CONDITIONING SYSTEM

1. WHAT'S AUTOMATIC AIR CONDITIONING SYSTEM?

Automatic air conditioning system automatically controls the interior room temperature, the blower speed, the air vent mode, etc, according to setting temperature of hope. It keeps good air condition at all seasons.

2. HOW FUNCTIONS DOES AUTOMATIC AIR CONDITIONING SYSTEM HAVE?

Automatic air conditioning system has four main functions as follows.

(1) Interior Room Temperature Control System & Blower Speed Control System

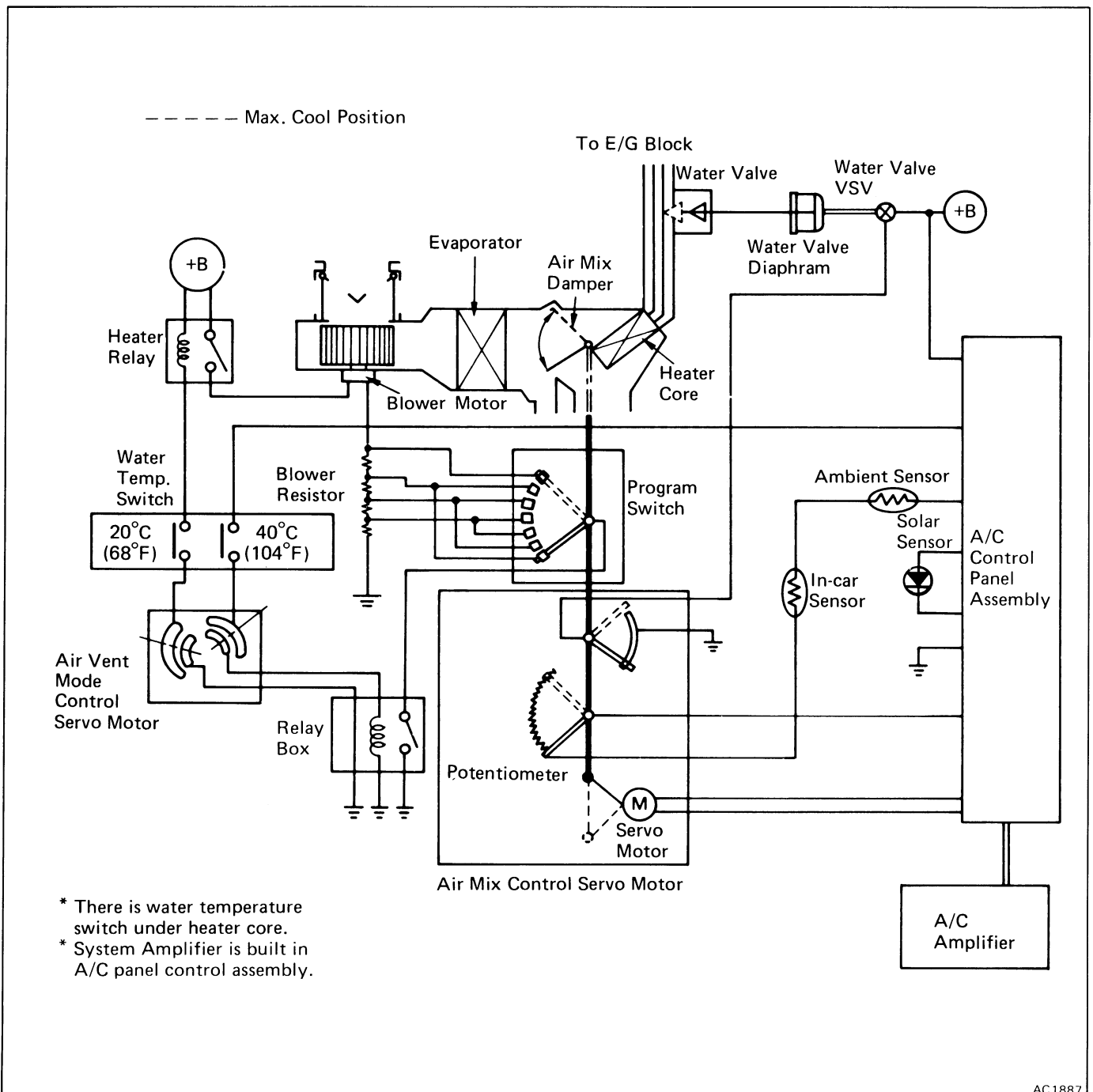

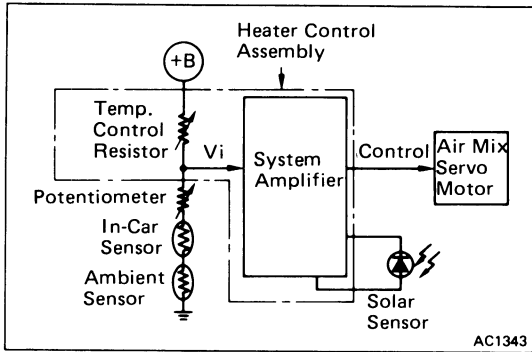

Interior Room Temperature Control System & Blower Speed Control System (Cont'd)

(a) Interior Room Temperature Control System

For example, now interior room temperature is rising.

- ① Resistance value of in-car sensor decreases.
- ② Voltage of V_i decreases.
- ③ System amplifier rotates a motor in air mix control servo motor.
- ④ Air mix control servo motor shaft moves towards max. cool side.
- ⑤ Resistance value of potentiometer increases.
- ⑥ Voltage of V_i increases in original condition.
- ⑦ Air mix control servo motor shaft stops.

* When air mix control servo motor shaft moves at max. cool position, water valve VSV is off. And water valve is close.

(b) Blower Speed Control System

As aforeside, according to moving of air mix control servo motor, blower speed is controlled.

Warm-up System condition: Blower Switch **AUTO** position.
Air Mode Switch is **AUTO** or **HEAT** position.

This system has a function that the blower unit blows cold air to your feet.

Water Temperature	Water Temperature Switch	Blower Motor
Less than 20°C (68°F)	20°C (68°F) Switch → OFF	OFF
20°C – 40°C (68°F – 104°F)	20°C (68°F) Switch → ON 40°C (104°F) Switch → OFF	Low Only
More than 40°C (104°F)	40°C (104°F) Switch → ON	Automatic Control

(2) Air Vent Mode Control System & RECIRC/FRESH Control System

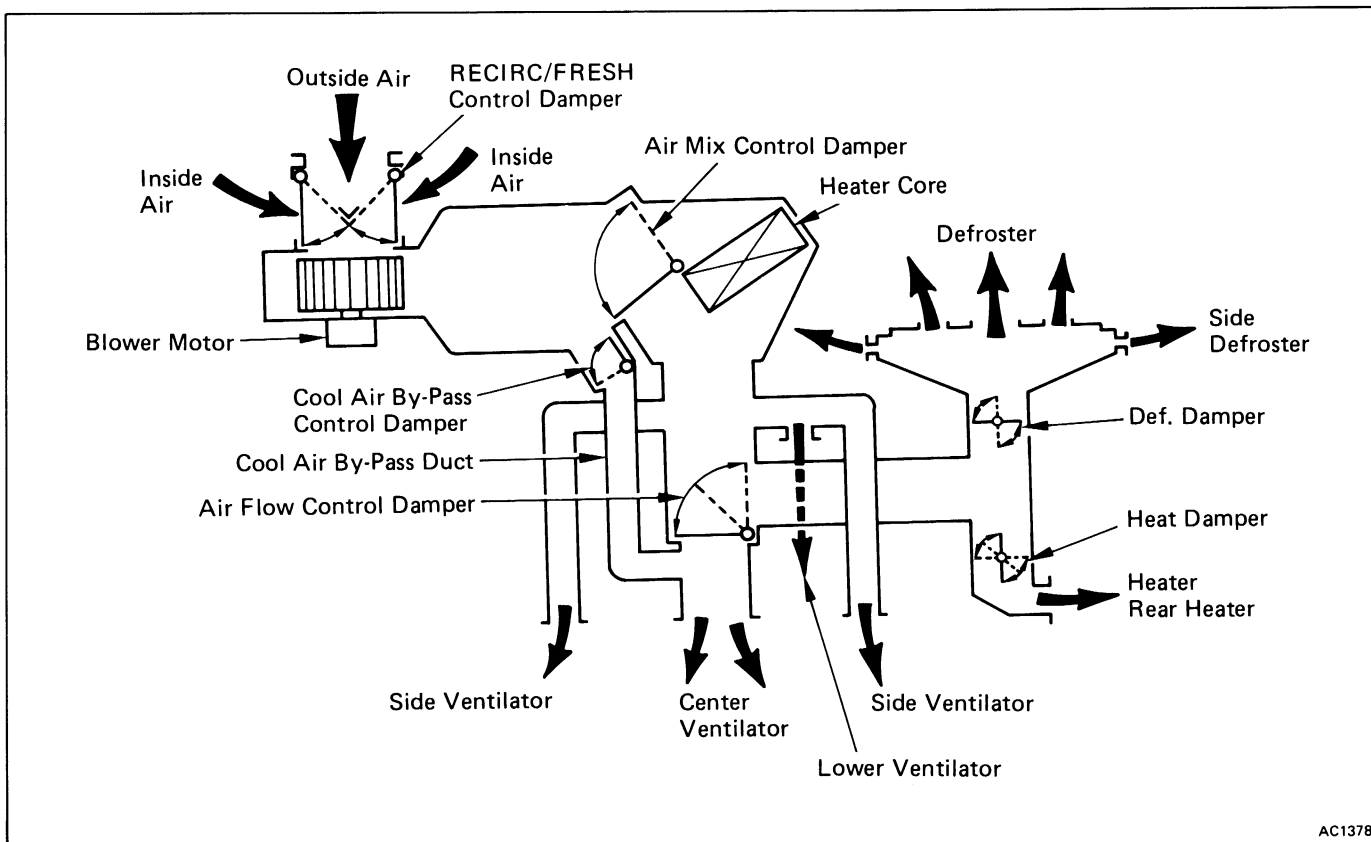

AC1378

(a) Air Vent Mode Control System

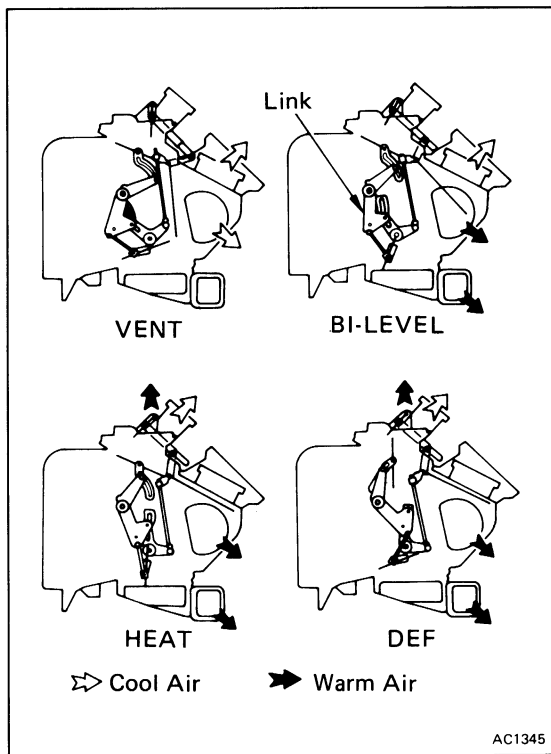

AC1345

Air-flow changes as follows.

- ① Air mix control servo motor shaft moves.
- ② Program switch is changed. (Signal is transmitted to relay box)
- ③ Relay box rotates a motor in air vent mode control servo motor.
- ④ Servo motor links move.
- ⑤ Each damper moves.
- ⑥ As aforeside, the air flows as shown left illustration.

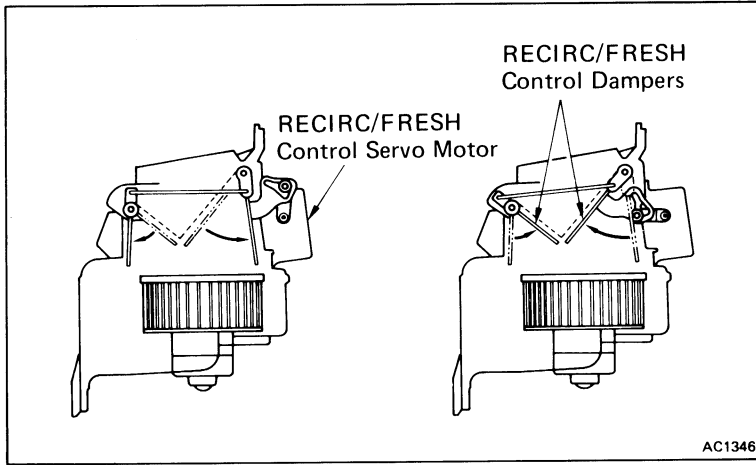

(b) RECIRC/FRESH Control System
RECIRC and FRESH changes as follows.

- ① RECIRC/FRESH control switch is pushed.
- ② System amplifier rotates a motor in RECIRC/FRESH control servo motor.
- ③ RECIRC/FRESH control dampers moves as shown left illustration.

SPECIAL TOOLS AND EQUIPMENT

Tool	SST No.	Use
Manifold gauge set	07110-58011	To evacuate and charge system
Ohmmeter	—	To perform electrical diagnosis
Voltage meter	—	To perform electrical diagnosis
Ammeter	—	To perform electrical diagnosis
Magnetic clutch stopper	07112-76060	To remove and install pressure plate
Magnetic clutch remover	07112-66040	To remove pressure plate
Snap ring pliers (External type)	07114-84020	To remove and install rotor and stator

SSM (SPECIAL SERVICE MATERIALS)

Part Name	Part No.	Use etc.
DENSO OIL 6, SUNISO No.5GS or equivalent	07117-68040 —	Compressor

TROUBLESHOOTING

You will find the troubles easier using the table well shown below. In this table, each number shows the priority of causes in troubles. Check each part in order. If necessary, replace these parts.

Trouble	Parts Name	See Page
No blower operation	Fuses	AC-4,6
No cool air come out	Circuit Breaker	AC-4,6
No warm air come out	Main Relay	AC-4,6
Cool air comes out inter- mittently	Wiring	AC-4,6
Limited amount of cool air at high speed	Wiring Connection	AC-4,6
Cool air comes out only at high speed	Refrigerant in System	AC-17
Insufficient velocity of cool air	Heater Relay	AC-31
Insufficient cooling	Blower Motor	AC-31
No blower control	Blower Resistor	AC-30
	Water Temp. SW 20°C (68°F)	AC-32
	Water Temp. SW 40°C (104°F)	AC-32
	Dual Pressure Switch	AC-32
	High Pressure Switch	AC-32
	Magnetic Clutch	AC-22
	Magnetic Clutch Relay	AC-31
	A/C Amplifier	AC-40
	Compressor	AC-22
	Condenser	AC-28
	Evaporator	AC-35
	Expansion Valve	AC-33
	Receiver	AC-28
	Thermistor	AC-37
	Drive Belt	AC-20
	A/C Switch	AC-38

TROUBLESHOOTING (Cont'd)

2						4	3	5	Blower Switch	AC-38
5						4	3		Temp. Control System	AC-32
5						4	4		Air Vent Mode Switch	AC-38
5						4	4		REC/FRE Control Switch	AC-38
3						4	4		In-Car Sensor	AC-42
3						4	4		Ambient Sensor	AC-42
3						4	4		Solar Sensor	AC-42
3						4	4		Potentiometer	AC-43
								6	Program Switch	AC-4, 6
4						4	4		Air Mix Control Servo	AC-45
4								5	Air Vent Mode Control Servo	AC-44
4						4	4		REC/FRE Control Servo	AC-44
4						4	4	7	System Amplifier	AC-40
						3			Water Valve VSV	
						3			Water Valve Diaphragm	
						3			Water Valve	
							3		Leak in System	
									Excessive Moisture in System	AC-19
					4				Air in System	AC-19
								5	Air or Excessive Compressor Oil in System	AC-19
									Air Inlet Blocked	
								3	Air Leakage from Cooling Unit or Air Duct	AC-19
1								7	Servo Motor Links	AC-43

Checking of Refrigeration System with Manifold Gauge

This is a method in which the trouble is located by using a manifold gauge. Read the manifold gauge pressure with the following conditions are established:

- (a) Temperature at the air inlet is 30 — 35°C (86 — 95°F)
- (b) Engine running at 1,500 rpm
- (c) Blower fan speed switch set at high speed
- (d) Temperature control lever set at cool side

HINT: It should be noted that the gauge indications may vary slightly due to ambient temperature conditions.

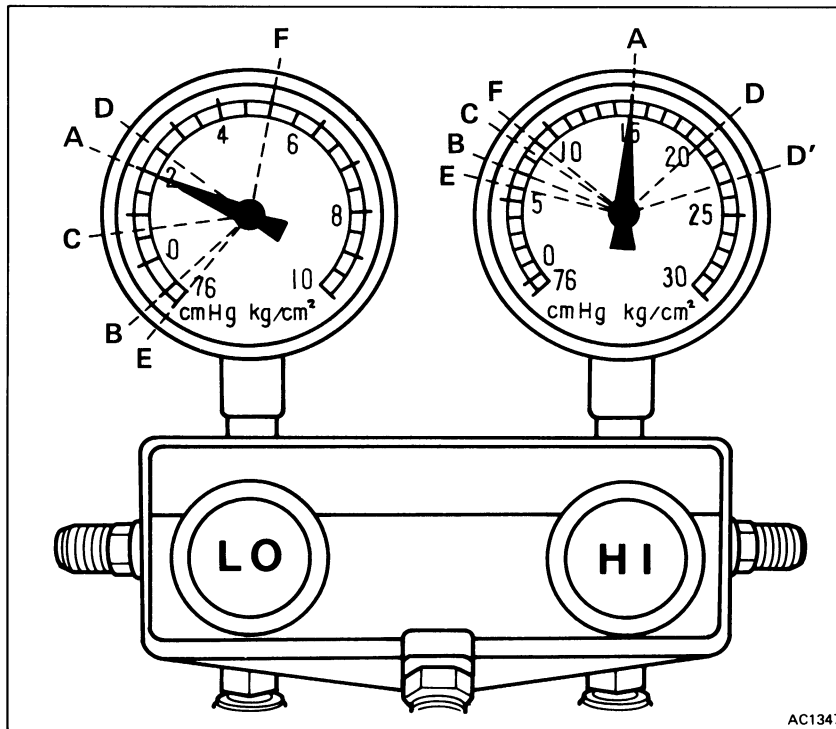

NORMALLY FUNCTIONING REFRIGERATION SYSTEM

Gauge reading:

Low pressure side

1.5 — 2.0 kg/cm²
(21 — 28 psi, 147 — 196 kPa)

High pressure side

14.5 — 15.0 kg/cm²
(206 — 213 psi, 1,422 — 1,471 kPa)

Each pointer of manifold gauge point to position A

No.	Trouble	Condition	Position of Pointers
1	Moisture present in refrigeration system	Periodically cools and then fails to cool	Between A and B
2	Insufficient refrigerant	Insufficient cooling	C
3	Poor circulation of refrigerant	Insufficient cooling	C
4	Refrigerant overcharge or insufficient cooling of condenser	Does not cool sufficiently	D
5	Expansion valve improperly mounted, heat sensing tube defective (opens too wide)	Insufficient cooling	D
6	Air present in refrigeration system	Does not cool sufficiently	Low is D High is D'
7	Refrigerant does not circulate	Does not cool (Cools from time to time in some cases)	E
8	Insufficient compression	Does not cool	F

Checking of Refrigeration System with Manifold Gauge (Cont'd)

No.	Symptom seen in refrigeration system	Probable cause	Diagnosis	Remedy
1	During operation, pressure at low pressure side sometimes becomes a vacuum and sometimes normal	Moisture entered in refrigeration system freezes at expansion valve orifice and temporarily stops cycle, but normal state is restored after a time when the ice melts	Drier in oversaturated state ↓ Moisture in refrigeration system freezes at expansion valve orifice and blocks circulation of refrigerant	(1) Replace receiver and drier (2) Remove moisture in cycle through repeated vacuum purging (3) Charge refrigerant to proper amount
2	Pressure low at both low and high pressure sides Bubbles seen in sight glass Insufficient cooling performance	Gas leakage at some place in refrigeration system	Insufficient refrigerant in system ↓ Refrigerant leaking	(1) Check with leak detector and repair (2) Charge refrigerant to proper amount
3	Pressure low at both low and high pressure sides Frost on tubes from receiver to unit	Refrigerant flow obstructed by dirt in receiver	Receiver clogged	Replace receiver
4	Pressure too high at both low and high pressure sides	Unable to develop sufficient performance due to excessive refrigerant in system Condenser cooling insufficient	Excess refrigerant in cycle → refrigerant overcharged Condenser cooling insufficient → condenser fins clogged or fan motor faulty	(1) Clean condenser (2) Check fan motor operation (3) If (1) and (2) are normal, check refrigerant amount HINT: Vent out refrigerant through gauge manifold low pressure side by gradually opening valve.
5	Pressure too high at both low and high pressure sides Frost or large amount of dew on piping at low pressure side	Trouble in expansion valve or heat sensing tube not installed correctly Refrigerant flow out	Excessive refrigerant in low pressure piping ↓ Expansion valve opened too wide	(1) Check heat sensing tube installed condition (2) If (1) is normal, test expansion valve in unit (3) Replace if defective
6	Pressure too high at both low and high pressure sides	Air entered refrigeration system	Air present in refrigeration system ↓ Insufficient vacuum purging	(1) Replace receiver and drier (2) Check compressor oil to see if dirty or insufficient (3) Vacuum purge and charge new refrigerant

*Note at No. 6

These gauge indications are shown when the refrigeration system has been opened and the refrigerant charged without vacuum purging.

Checking of Refrigeration System with Manifold Gauge (Cont'd)

No.	Symptom seen in refrigeration system	Probable cause	Diagnosis	Remedy
7	<p>Vacuum indicated at low pressure side, very low pressure indicated at high pressure side</p> <p>Frost or dew seen on piping before and after receiver and drier or expansion valve</p>	<p>Refrigerant flow obstructed by moisture or dirt in refrigerant freezing or adhering to expansion valve orifice</p> <p>Refrigerant flow obstructed by gas leakage from expansion valve heat sensing tube</p>	<p>Expansion valve orifice clogged</p> <p style="text-align: center;">↓</p> <p>Refrigerant does not flow</p>	<p>Allow to stand for some time and then restart operation to determine if trouble is caused by moisture or dirt.</p> <p>If caused by moisture refer to procedures Step 2 on page AC-18.</p> <p>If caused by dirt, remove expansion valve and clean off dirt by blowing with air. If unable to remove dirt, replace valve.</p> <p>Vacuum purge and charge new refrigerant to proper amount.</p> <p>For gas leakage from heat sensing tube, replace expansion valve.</p>
8	<p>Pressure too high at low pressure side</p> <p>Pressure too low at high pressure side</p>	<p>Internal leak in compressor</p>	<p>Compression defective</p> <p style="text-align: center;">↓</p> <p>Valve leaking or broken sliding parts (Piston, cylinder, gasket, etc.) broken</p>	<p>Repair or replace compressor</p>

Discharging of Refrigeration System Evacuating and Charging of Refrigeration System

(See Air Conditioning Fundamentals and Repairs Pub. No. 36950E)

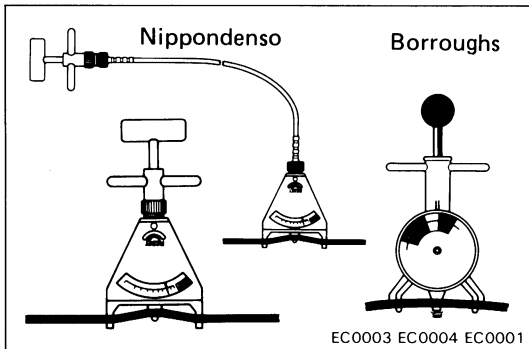
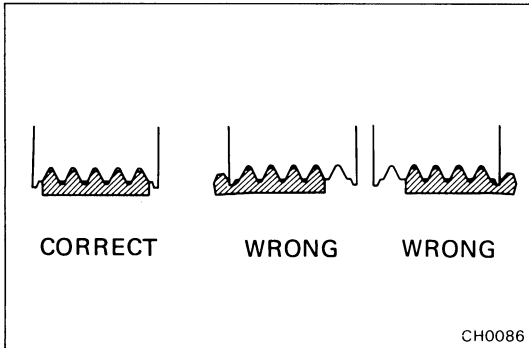

ON-VEHICLE INSPECTION

1. CHECK CONDENSER FINS FOR BLOCKAGE OR DAMAGE

If the fins are clogged, clean them with pressurized water.

CAUTION: Be careful not to damage the fins.

2. MAKE SURE THAT DRIVE BELT IS INSTALLED CORRECTLY

After installing the drive belt, check that it fits properly in the ribbed grooves.

3. CHECK DRIVE BELT TENSION

Using a belt tension gauge, check the drive belt tension.

Belt tension gauge:

Nippondenso BTG-20(95506-00020) or

Borroughs No.BT-33-73F

Drive belt tension:

New belt 160 ± 20 lb

Used belt 105 ± 10 lb

HINT:

- "New belt" refers to a belt which has been used less than 5 minutes on a running engine.
- "Used belt" refers to a belt which has been used on a running engine for 5 minutes or more.

4. START ENGINE

5. TURN ON A/C SWITCH

Check that the A/C operates at each position of the blower switch.

6. CHECK MAGNETIC CLUTCH OPERATION

If magnetic clutch does not engage, check the A/C fuse.

7. CHECK THAT IDLE INCREASES

When the magnetic clutch engages, engine revolution should increase.

Standard idle-up rpm:

	M/T (N range)	A/T (D range)
7M-GTE E/G	900 rpm	700 rpm
7M-GE E/G	900 rpm	650 rpm

8. CHECK CONDENSER FAN MOTOR ROTATES

9. CHECK AMOUNT OF REFRIGERANT

If you can see bubbles in the sight glass, additional refrigerant is needed. (See page AC-21)

10. IF NO COOLING OR IT IS INSUFFICIENT, INSPECT FOR LEAKAGE

Using a gas leak detector, inspect each component of the refrigeration system.

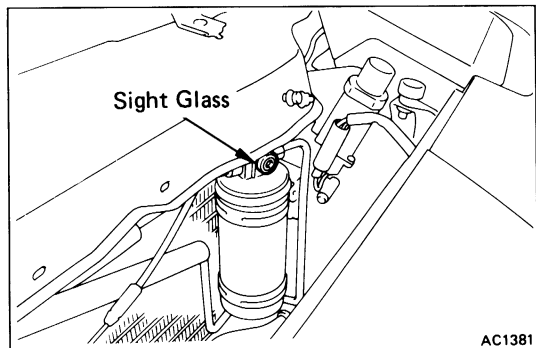

REFRIGERATION SYSTEM

Checking of Refrigerant Volume

1. RUN ENGINE AT APPROX. 2,000 RPM
2. OPERATE AIR CONDITIONER AT MAXIMUM COOLING FOR A FEW MINUTES
3. CHECK AMOUNT OF REFRIGERANT
Observe the sight glass on the receiver.

Item	Symptom	Amount of refrigerant	Remedy
1	Bubbles present in sight glass	Insufficient	Check for leak with gas leak detector
2	No bubbles present in sight glass	Empty, proper or too much	Refer to items 3 and 4
3	No temperature difference between compressor inlet and outlet	Empty or nearly empty	Evacuate and charge system. Then check for leak with gas leak detector
4	Temperature between compressor inlet and outlet is noticeably different	Proper or too much	Refer to items 5 and 6
5	Immediately after the air conditioner is turned off, refrigerant in sight glass stays clear	Too much	Discharge the excess refrigerant to specified amount
6	When the air conditioner is turned off, refrigerant foams and then stays clear	Proper	—

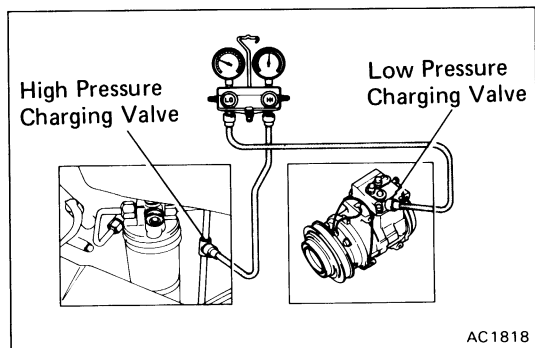

Installation of Manifold Gauge Set

1. CLOSE BOTH HAND VALVES OF MANIFOLD GAUGE SET
2. INSTALL CHARGING HOSES OF GAUGE SET TO CHARGING VALVES

Connect the low pressure hose (Blue) to the low pressure charging valve and the high pressure hose (Red) to the high pressure charging valve. Tighten the hose nuts by hand.

HINT: Do not apply compressor oil to the seat of the connection.

COMPRESSOR

ON-VEHICLE INSPECTION

1. **INSTALL MANIFOLD GAUGE SET**
(See page AC-21)

2. **RUN ENGINE AT APPROX. 1,500 RPM**

3. **CHECK COMPRESSOR FOR FOLLOWING:**
 - (a) High pressure gauge reading is not lower and low pressure gauge reading is not higher than normal.
 - (b) Metallic sound
 - (c) Leakage from shaft seal

If defects are found, repair the compressor.

4. **CHECK MAGNETIC CLUTCH**
 - (a) Inspect the pressure plate and the rotor for signs of oil.
 - (b) Check the clutch bearings for noise and grease leakage.

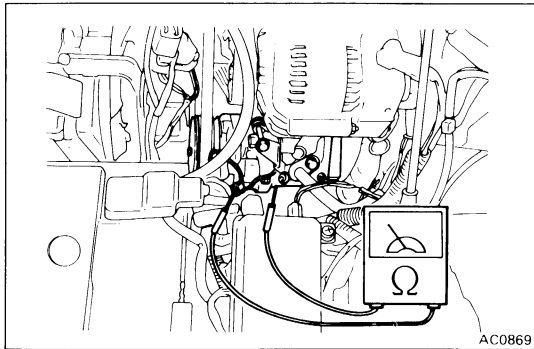

- (c) Using an ohmmeter, measure the resistance of the stator coil between the clutch lead wire and ground.

Standard resistance: 2.7 – 3.1 Ω at 20°C (68°F)

If resistance value is not as specified, replace the coil.

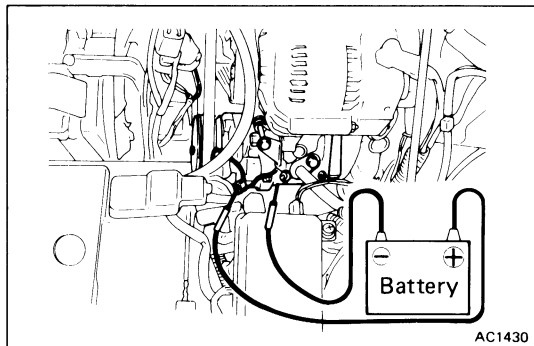

- (d) Connect the positive (+) lead from the battery to terminal 1, check that the magnetic clutch is energized.

If magnetic clutch is not energized, replace the coil.

NOTICE: Do not short the positive (+) lead wire on the vehicle by applying battery voltage.

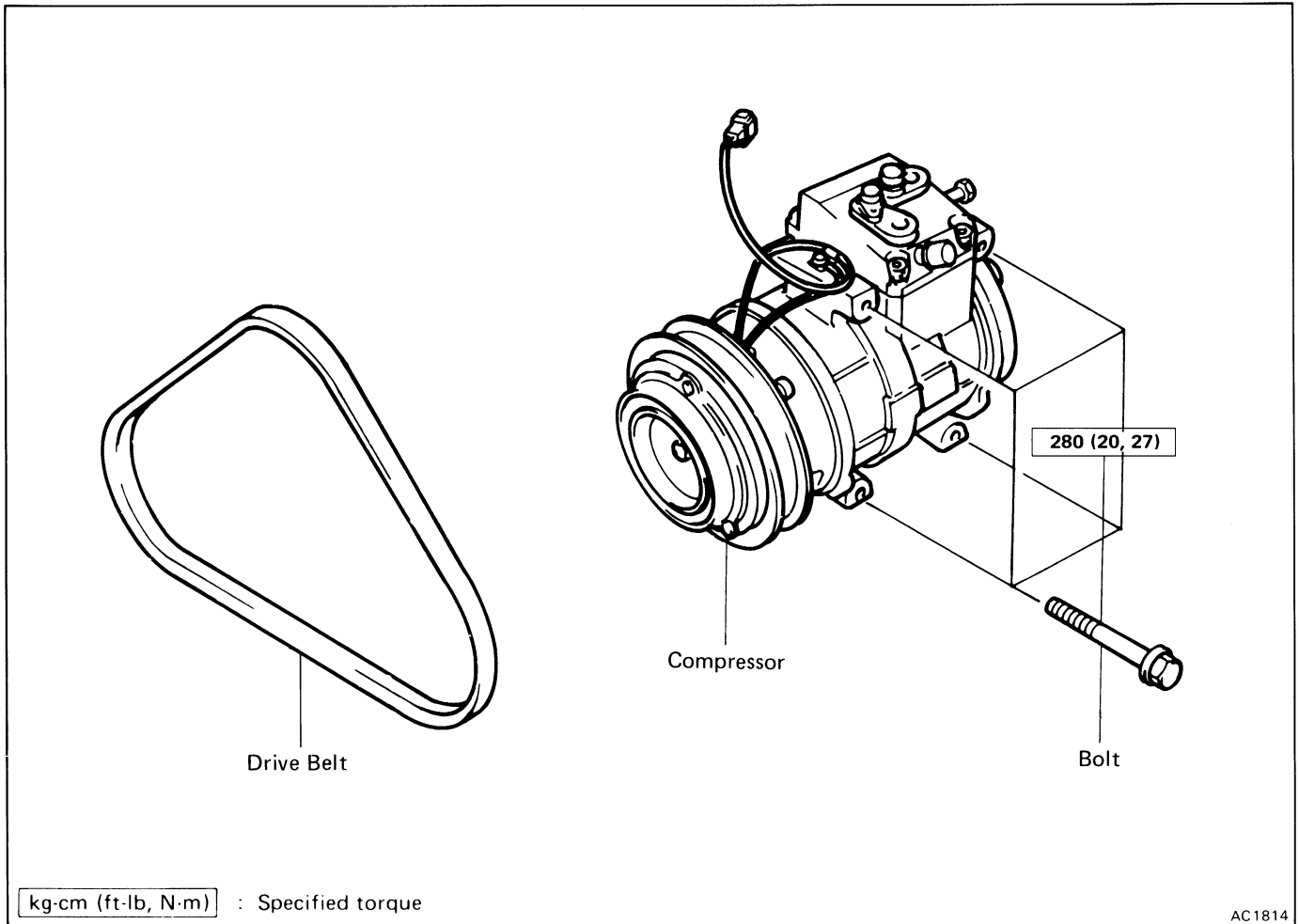

REMOVAL OF COMPRESSOR

1. RUN ENGINE AT IDLE SPEED WITH AIR CONDITIONING ON FOR 10 MINUTES
2. STOP ENGINE
3. DISCONNECT NEGATIVE AND POSITIVE CABLE FROM BATTERY
4. REMOVE BATTERY
5. DISCONNECT CLUTCH LEAD WIRE FROM WIRING HARNESS
6. DISCHARGE REFRIGERANT FROM REFRIGERATION SYSTEM
7. DISCONNECT TWO HOSES FROM COMPRESSOR SERVICE VALVES
Cap the open fitting immediately to keep moisture out of the system.
8. REMOVE COMPRESSOR
 - (a) Loosen the drive belt.
 - (b) Remove the compressor mounting bolts and the compressor.

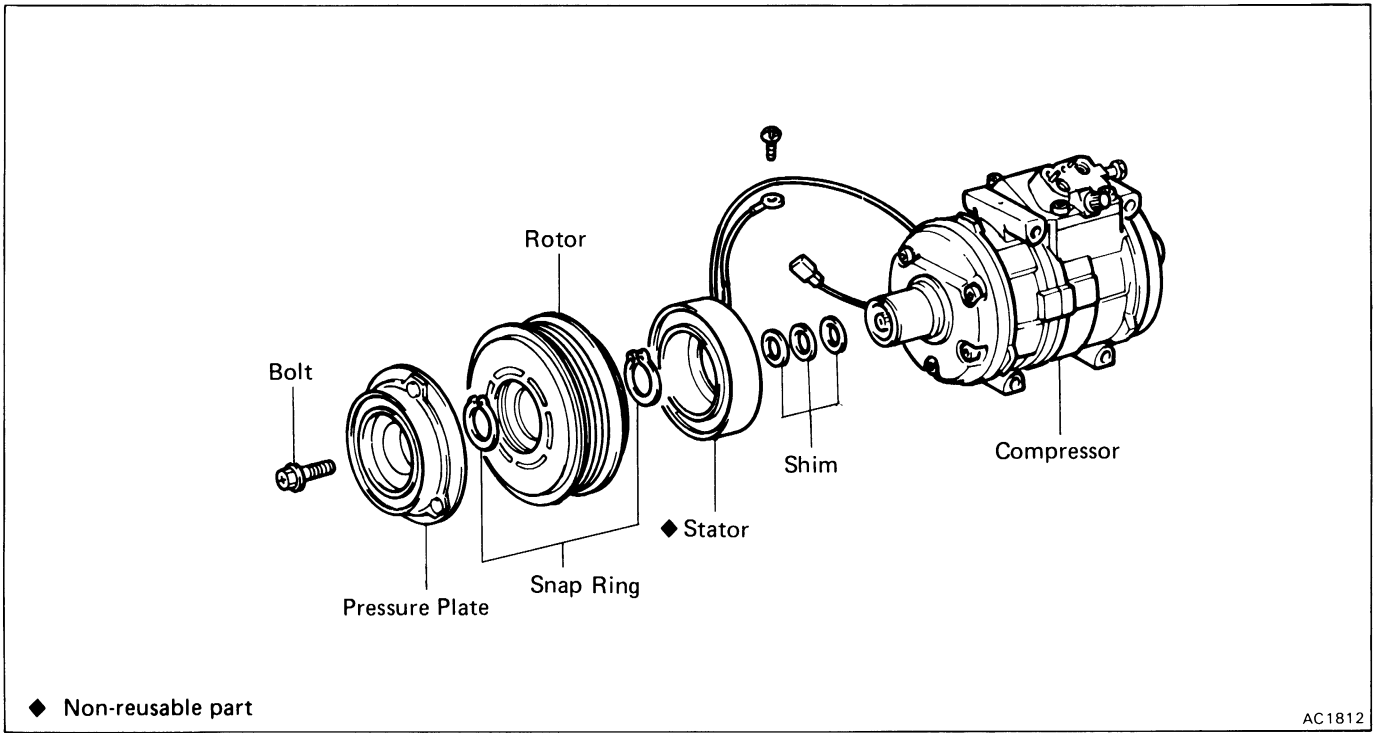

DISASSEMBLY OF MAGNETIC CLUTCH

1. REMOVE PRESSURE PLATE

(a) Using SST and socket, remove the shaft bolt.
SST 07112-76060

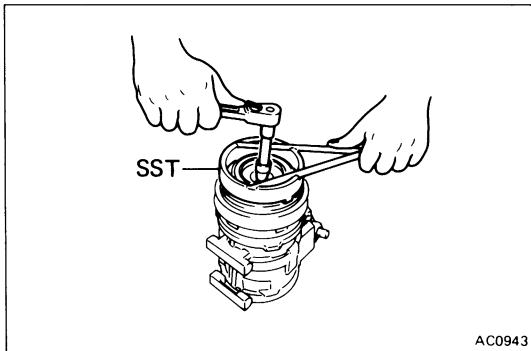

(b) Install SST to the pressure plate.
SST 07112-66040

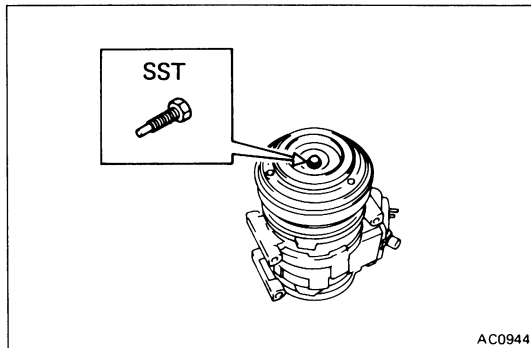

(c) Using SST and the socket, remove the pressure plate.
SST 07112-76060

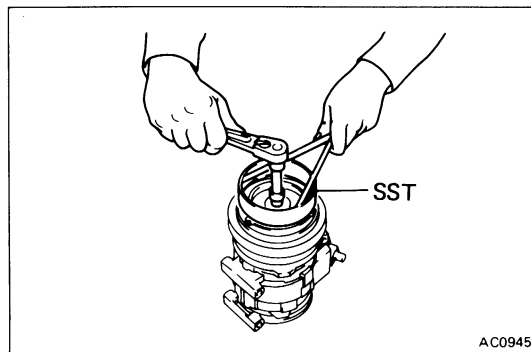

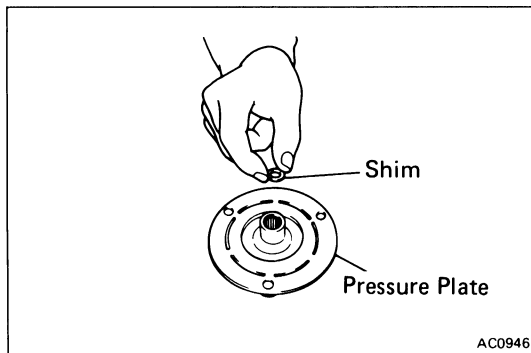

(d) Remove the shims from the pressure plate.

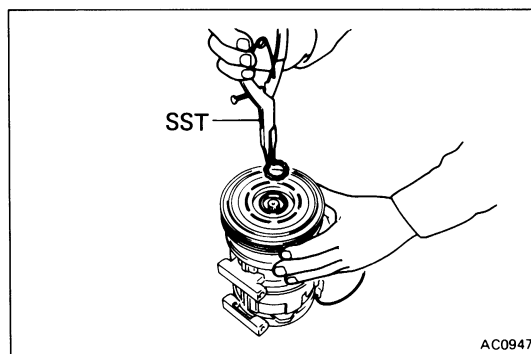

2. REMOVE ROTOR

(a) Using SST, remove the snap ring.

SST 07114-84020

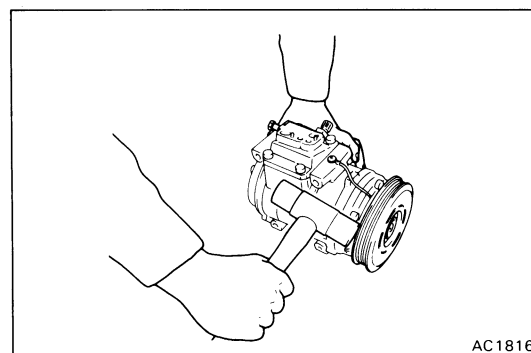

(b) Using a plastic hammer, tap the rotor off the shaft.

NOTICE: Be careful not to damage the pulley when tapping on the rotor.

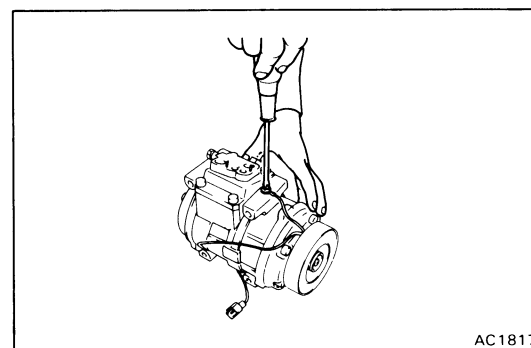

3. REMOVE STATOR

(a) Disconnect the stator lead wire from the compressor housing.

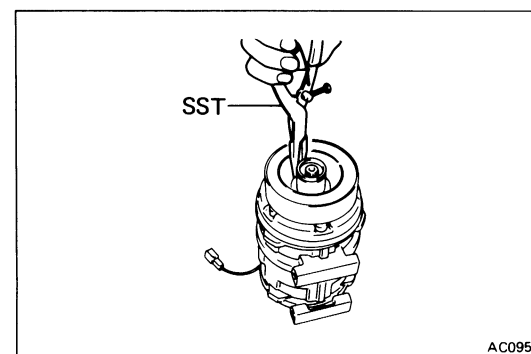

(b) Using SST, remove the snap ring.

SST 07114-84020

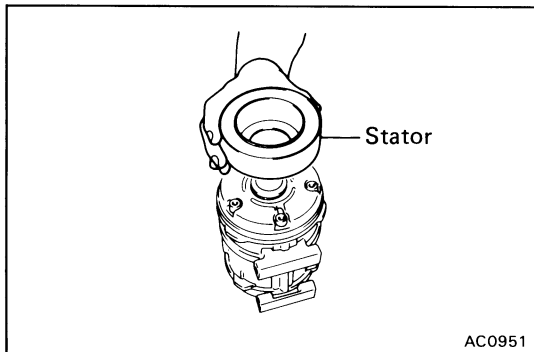

(c) Remove the stator.

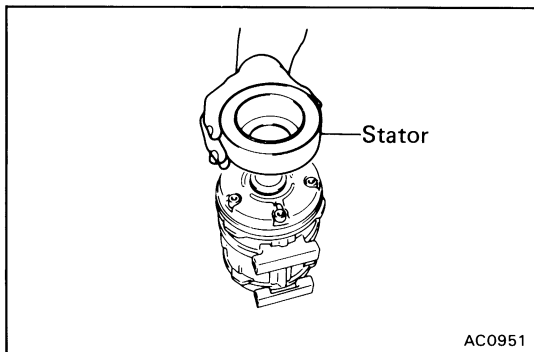

ASSEMBLY OF MAGNETIC CLUTCH

1. INSTALL STATOR

(a) Install the stator on the compressor.

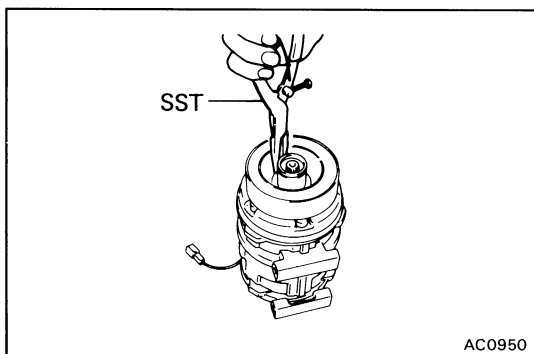

(b) Using SST, install the new snap ring.
SST 07114-84020

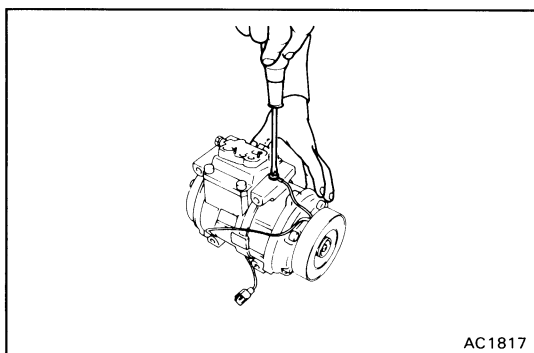

(c) Connect the stator lead wires to the compressor housing.

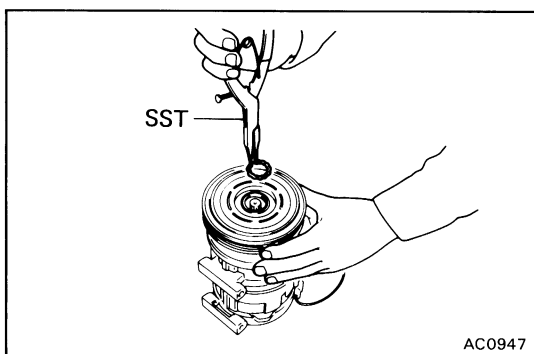

2. INSTALL ROTOR

(a) Install the rotor on the compressor shaft.

(b) Using SST, install the new snap ring.
SST 07114-84020

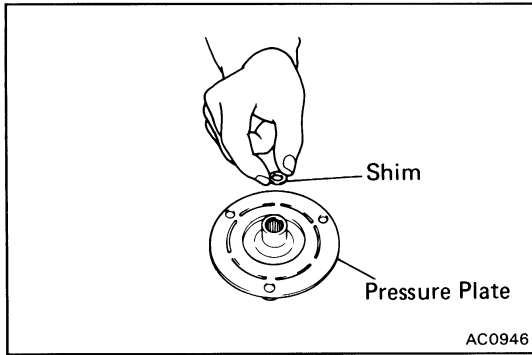

3. INSTALL PRESSURE PLATE

(a) Install the shims to the pressure plate.

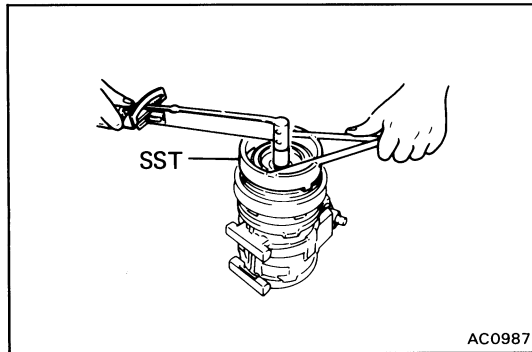

(b) Using SST and torque wrench, install the shaft bolt.
SST 07112-76060

Torque: 140 kg-cm (10 ft-lb, 14 N·m)

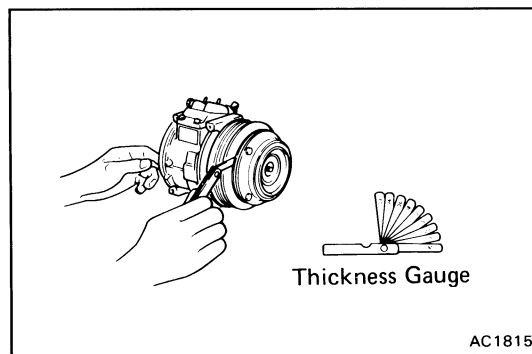

4. CHECK CLEARANCE OF MAGNETIC CLUTCH

Check the clearance between the pressure plate and rotor using thickness gauge.

Standard clearance: 0.5 ± 0.15 mm (0.020 ± 0.006 in.)

If the clearance is not within tolerance, change the number of shims to obtain the standard clearance.

INSTALLATION OF COMPRESSOR

(See page AC-23)

1. INSTALL COMPRESSOR WITH FOUR MOUNTING BOLTS

Torque: 250 kg-cm (18 ft-lb, 25 N·m)

2. INSTALL DRIVE BELT

(See steps 2 and 3 on page AC-20)

3. CONNECT TWO HOSES TO COMPRESSOR SERVICE VALVES

Torque:

Discharge line 250 kg-cm (18 ft-lb, 25 N·m)

Suction line 250 kg-cm (18 ft-lb, 25 N·m)

4. CONNECT CLUTCH LEAD WIRE TO WIRING HARNESS

5. PLACE BATTERY

6. CONNECT NEGATIVE CABLE TO BATTERY

7. EVACUATE AIR FROM AIR CONDITIONING SYSTEM

8. CHARGE AIR CONDITIONING SYSTEM WITH REFRIGERANT AND CHECK FOR GAS LEAKAGE

Specified amount: 650 — 750 g (1.4 — 1.7 lb)

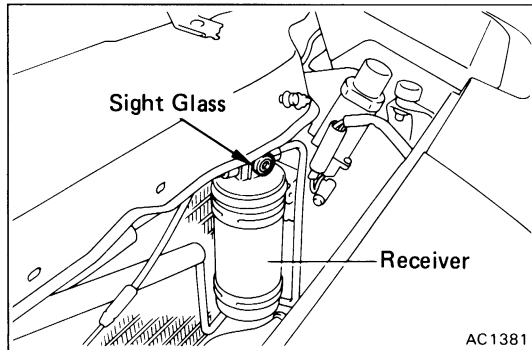

RECEIVER

(See page AC-8)

ON-VEHICLE INSPECTION

CHECK SIGHT GLASS, FUSIBLE PLUG AND FITTINGS FOR LEAKAGE

Use a gas leak detector. Repair as necessary.

REMOVAL OF RECEIVER

1. DISCHARGE REFRIGERATION SYSTEM
2. DISCONNECT TWO LIQUID TUBES FROM RECEIVER
HINT: Cap the open fittings immediately to keep moisture out of the system.
3. REMOVE RECEIVER FROM RECEIVER HOLDER

INSTALLATION OF RECEIVER

1. INSTALL RECEIVER IN RECEIVER HOLDER
HINT: Do not remove the blind plugs until ready for connection.
2. CONNECT TWO LIQUID TUBES TO RECEIVER
Torque: 55 kg-cm (4 ft-lb, 5 N·m)
3. IF RECEIVER WAS REPLACED, ADD COMPRESSOR OIL TO COMPRESSOR
Add 20 cc (0.7 fl.oz.)
Compressor oil: DENSOIL 6,
SUNISO No.5GS or equivalent
4. EVACUATE AIR FROM AIR CONDITIONING SYSTEM
5. CHARGE AIR CONDITIONING SYSTEM WITH REFRIGERANT AND CHECK FOR GAS LEAKAGE
Specified amount: 650 — 750 g (1.4 — 1.7 lb)

CONDENSER

(See page AC-8)

ON-VEHICLE INSPECTION

1. CHECK CONDENSER FINS FOR BLOCKAGE OR DAMAGE
If the fins are clogged, wash them with water and dry with compressed air.
NOTICE: Be careful not to damage the fins.
If the fins are bent, straighten them with a screwdriver or pliers.
2. CHECK CONDENSER FITTINGS FOR LEAKAGE
Repair as necessary.

REMOVAL OF CONDENSER

1. DISCHARGE REFRIGERATION SYSTEM

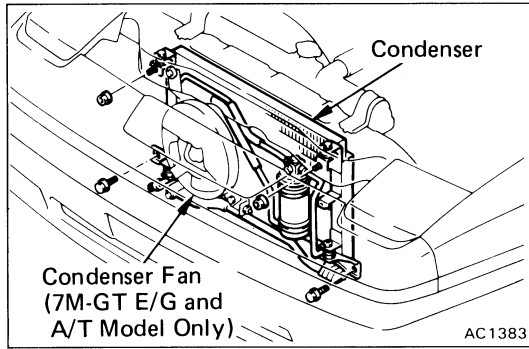
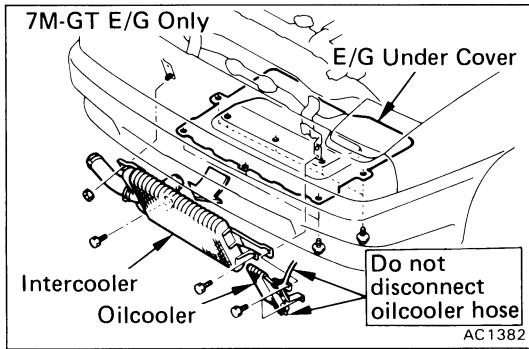
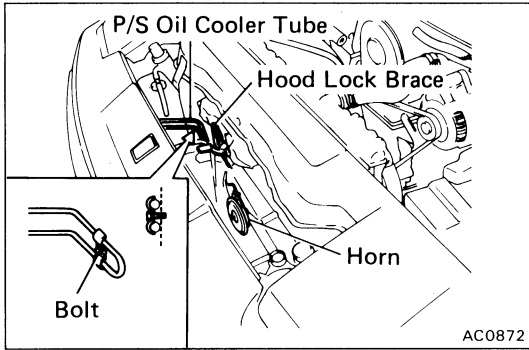

2. REMOVE FOLLOWING COMPONENTS:

- (a) Hood lock brace
- (b) Center brace with horn
- (c) Washer tank with bracket
- (d) Engine under cover (7M-GTE E/G only)
- (e) Intercooler (7M-GTE E/G only)
- (f) Oilcooler (7M-GTE E/G only)
- (g) Condenser fan (7M-GTE E/G and A/T model only)

3. DISCONNECT DISCHARGE HOSE AND SUCTION HOSE

4. DISCONNECT LIQUID TUBE AND SUCTION TUBE

HINT: Cap the open fittings immediately to keep moisture out of the system.

5. REMOVE CONDENSER

Remove two nuts and two bolts.

INSTALLATION OF CONDENSER

1. INSTALL CONDENSER

(See page AC-8)

2. CONNECT DISCHARGE HOSE AND SUCTION HOSE

Torque:

Discharge hose	250 kg-cm (18 ft-lb, 25 N·m)
Suction hose	325 kg-cm (24 ft-lb, 32 N·m)

3. CONNECT LIQUID TUBE AND SUCTION TUBE

Torque:

Liquid tube	135 kg-cm (10 ft-lb, 13 N·m)
Suction tube	325 kg-cm (24 ft-lb, 32 N·m)

4. INSTALL FOLLOWING COMPONENTS:

- (a) Hood lock brace
- (b) Center brace with horn
- (c) Washer tank with bracket
- (d) Engine under cover (7M-GTE E/G only)
- (e) Intercooler (7M-GTE E/G only)
- (f) Oilcooler (7M-GTE E/G only)
- (g) Condenser fan (7M-GTE E/G and A/T model only)

5. IF CONDENSER WAS REPLACED, ADD COMPRESSOR OIL TO COMPRESSOR

Add 40 — 50 cc (1.4 — 1.7 fl.oz.)

Compressor oil: **DENSOIL 6,**
SUNISO No.5GS or equivalent

6. EVACUATE AIR FROM AIR CONDITIONING SYSTEM

7. CHARGE AIR CONDITIONING SYSTEM WITH REFRIGERANT AND CHECK FOR GAS LEAKAGE

Specified amount: 650 — 750 g (1.4 — 1.7 lb)

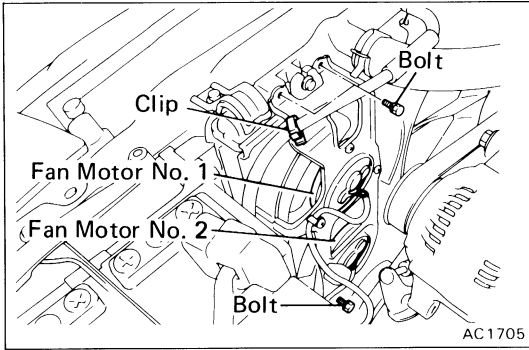

CONDENSER FAN MOTORS

INSPECTION OF CONDENSER FAN MOTORS

1. DISCONNECT NEGATIVE CABLE FROM BATTERY
2. DISCONNECT CONNECTOR OF FAN MOTOR
3. CHECK FAN MOTOR
 - (a) Using the wire harness, apply battery voltage (12V) to the connector.
 - (b) Confirm smooth rotation of the motor within the specified current flow.

Standard current:

Fan motor No.1 and No.2

8.0 ± 0.8 A (7M-GTE E/G and M/T model)

6.7 ± 0.7 A (7M-GTE E/G and A/T model or 7M-GE E/G model)

Fan motor No.3

6.7 ± 0.7 A (7M-GTE E/G and A/T model only)

If defective, replace the motor.

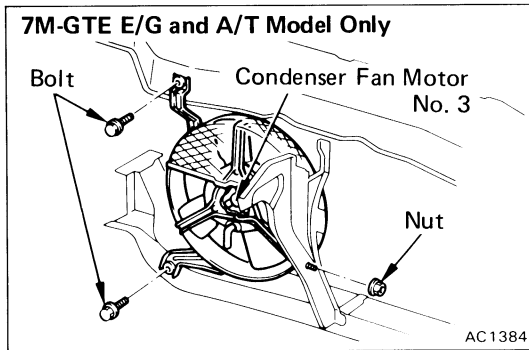

4. CONNECT CONNECTOR OF FAN MOTOR
5. CONNECT NEGATIVE CABLE TO BATTERY

HEATER BLOWER RESISTOR

INSPECTION OF RESISTOR

INSPECT RESISTOR RESISTANCE

Check that there is continuity between terminals 4 and 6.

If there is no continuity, replace the resistor.

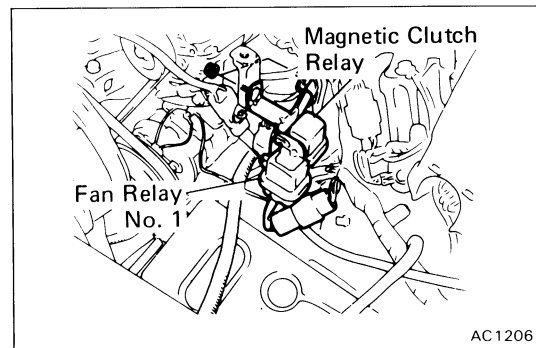
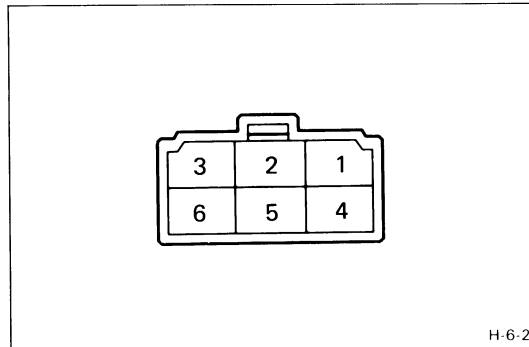

RELAYS

INSPECTION OF RELAYS

1. REMOVE RELAYS

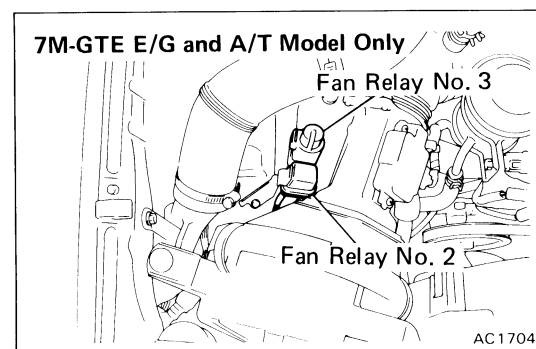

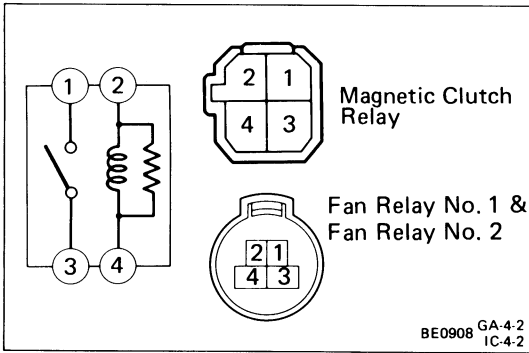

2. INSPECT RELAY CONTINUITY

(Magnetic Clutch Relay)

(Fan Relay No. 1)

(Fan Relay No.2 ; 7M-GTE E/G and A/T Model)

○—○ : Continuity

Terminals	1	2	3	4
Condition				
Constant		○—○	○—○	
Apply battery voltage to terminal 2 and 4	○		○	

(Fan Relay No.3 ; 7M-GTE E/G and A/T Model)

Terminals	1	2	3	4
Condition				
Constant	○—○		○—○	○—○
Apply battery voltage to terminal 1 and 2				No continuity

If continuity is not as specified, replace the relay.

(Heater Relay)

- (a) Check that there is continuity between terminals 1 and 3.
- (b) Check that there is continuity between terminals 2 and 4.
- (c) Check that there is no continuity between terminals 4 and 5.

If continuity is not as specified, replace the relay.

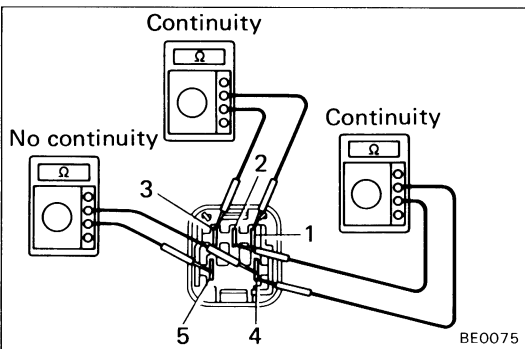
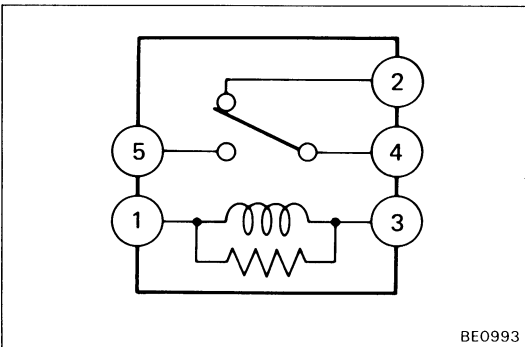
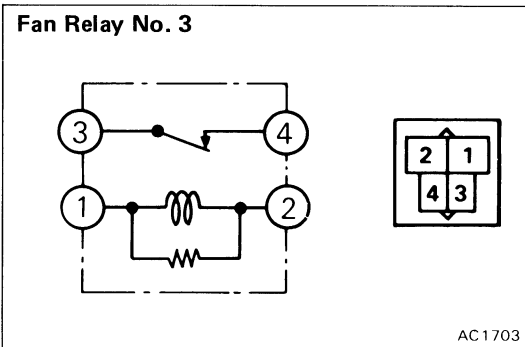

3. INSPECT RELAY OPERATION

(Heater Relay)

- (a) Apply battery voltage to terminals 1 and 3.
- (b) Check that there is continuity between terminals 4 and 5.
- (c) Check that there is no continuity between terminals 2 and 4.

If operation is not as specified, replace the relay.

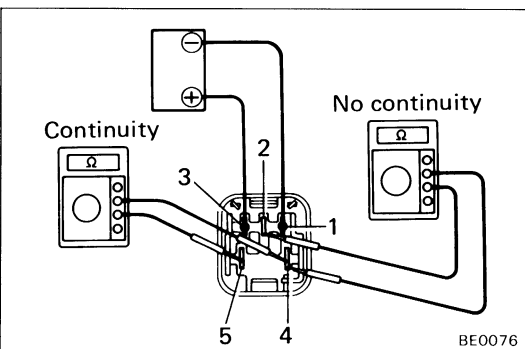

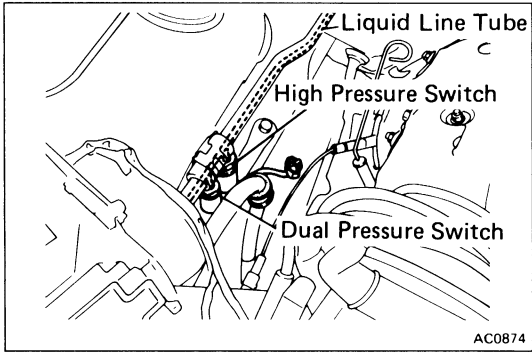

PRESSURE SWITCH

(See page AC-8)

ON-VEHICLE INSPECTION

1. DISCONNECT CONNECTOR OF PRESSURE SWITCH
2. INSPECT PRESSURE SWITCH
 - (a) Install the manifold gauge set. (See page AC-21)
 - (b) Observe the gauge reading.
 - (c) Check the continuity between two terminals of the pressure switch shown in the below.

Dual Pressure Switch

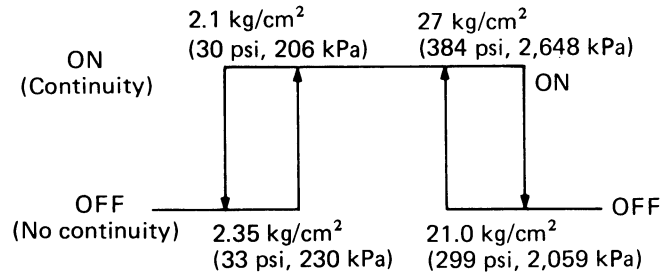

AC1349

If defective, replace the pressure switch.

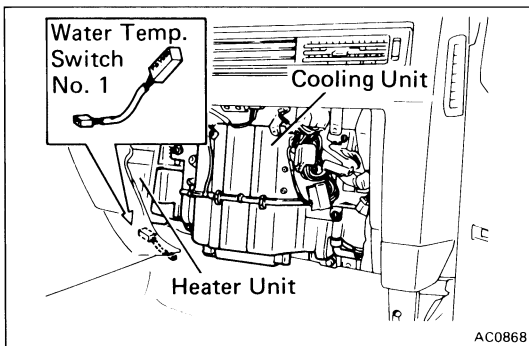

WATER TEMPERATURE SWITCH

HINT: The water temperature switch is under the heater radiator.

INSPECTION OF WATER TEMPERATURE SWITCH NO. 1

INSPECT SWITCH CONTINUITY

Terminals	1	2	3	4
Water Temp.				
15°C (59°F) or below	No continuity			
25°C (77°F) or more	○	—	—	○
45°C (113°F) or more	○	○	—	○

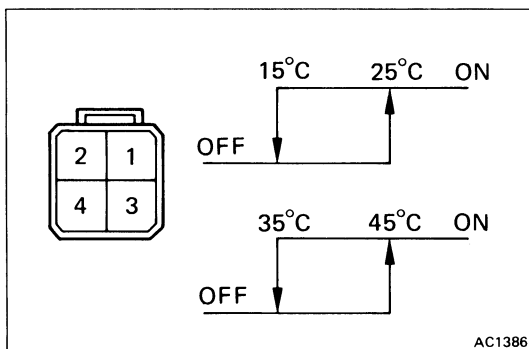

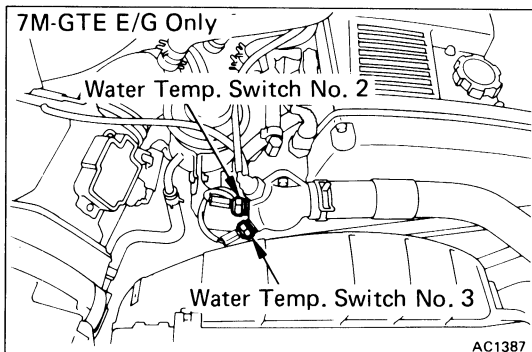

INSPECTION OF WATER TEMPERATURE SWITCH NO.2, NO.3 (7M-GTE E/G MODEL ONLY)

INSPECT SWITCH CONTINUITY

Inspect the switch continuity between each terminal at each water temperature.

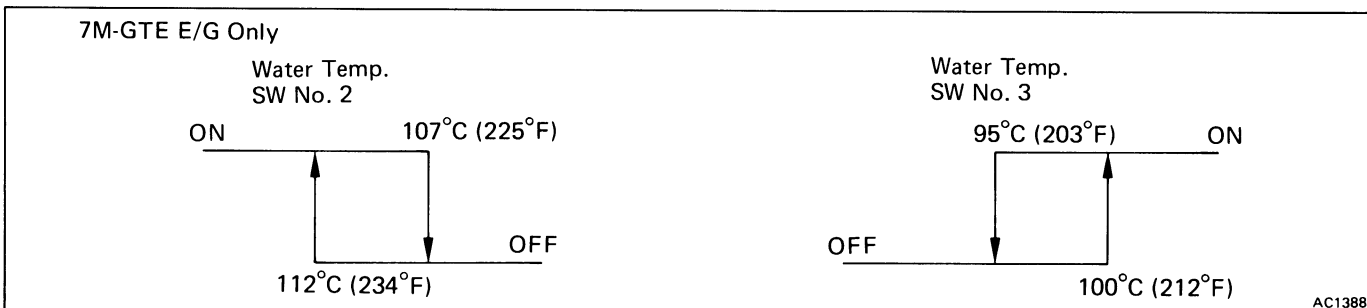

If defective, replace the switch.

COOLING UNIT

(See page AC-8)

ON-VEHICLE INSPECTION OF EXPANSION VALVE

1. CHECK QUANTITY OF REFRIGERANT GAS DURING REFRIGERATION CYCLE
2. INSTALL MANIFOLD GAUGE SET (See page AC-21)
3. RUN ENGINE

Run the engine at 2,000 rpm for at least 5 minutes.

4. CHECK EXPANSION VALVE

If the expansion valve is clogged, the low pressure reading will drop to 0 kg/cm² (0 psi, 0 kPa), otherwise it is OK.

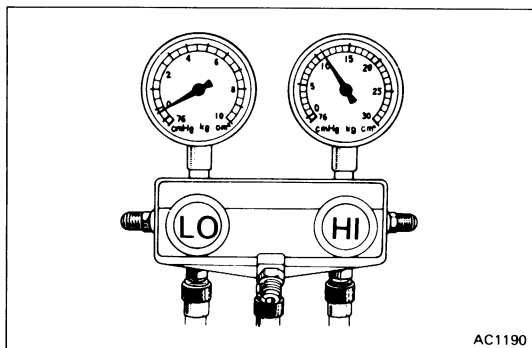

REMOVAL OF COOLING UNIT

1. DISCONNECT NEGATIVE CABLE FROM BATTERY
2. DISCHARGE REFRIGERATION SYSTEM
3. REMOVE CHARCOAL CANISTER WITH BRACKET
4. DISCONNECT SUCTION TUBE FROM COOLING UNIT OUTLET FITTING
5. DISCONNECT LIQUID TUBE FROM COOLING UNIT INLET FITTING

HINT: Cap the open fittings immediately to keep moisture out of the system.

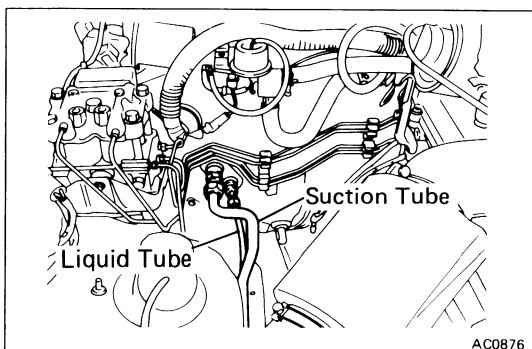

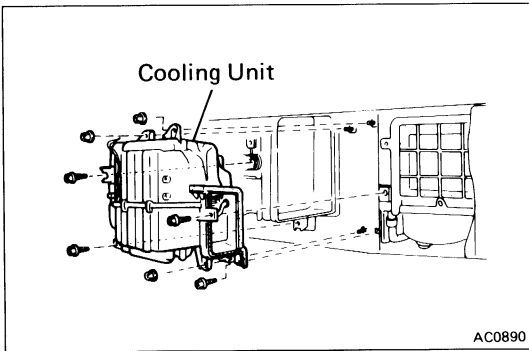

6. REMOVE GROMMETS FROM INLET AND OUTLET FITTINGS
7. REMOVE GLOVE BOX AND UNDER COVER
8. REMOVE GLOVE BOX COVER AND REINFORCEMENT
9. REMOVE EFI AND A.B.S. COMPUTER
10. DISCONNECT CONNECTOR
11. REMOVE COOLING UNIT
Remove four screws and three nuts.

DISASSEMBLY OF COOLING UNIT

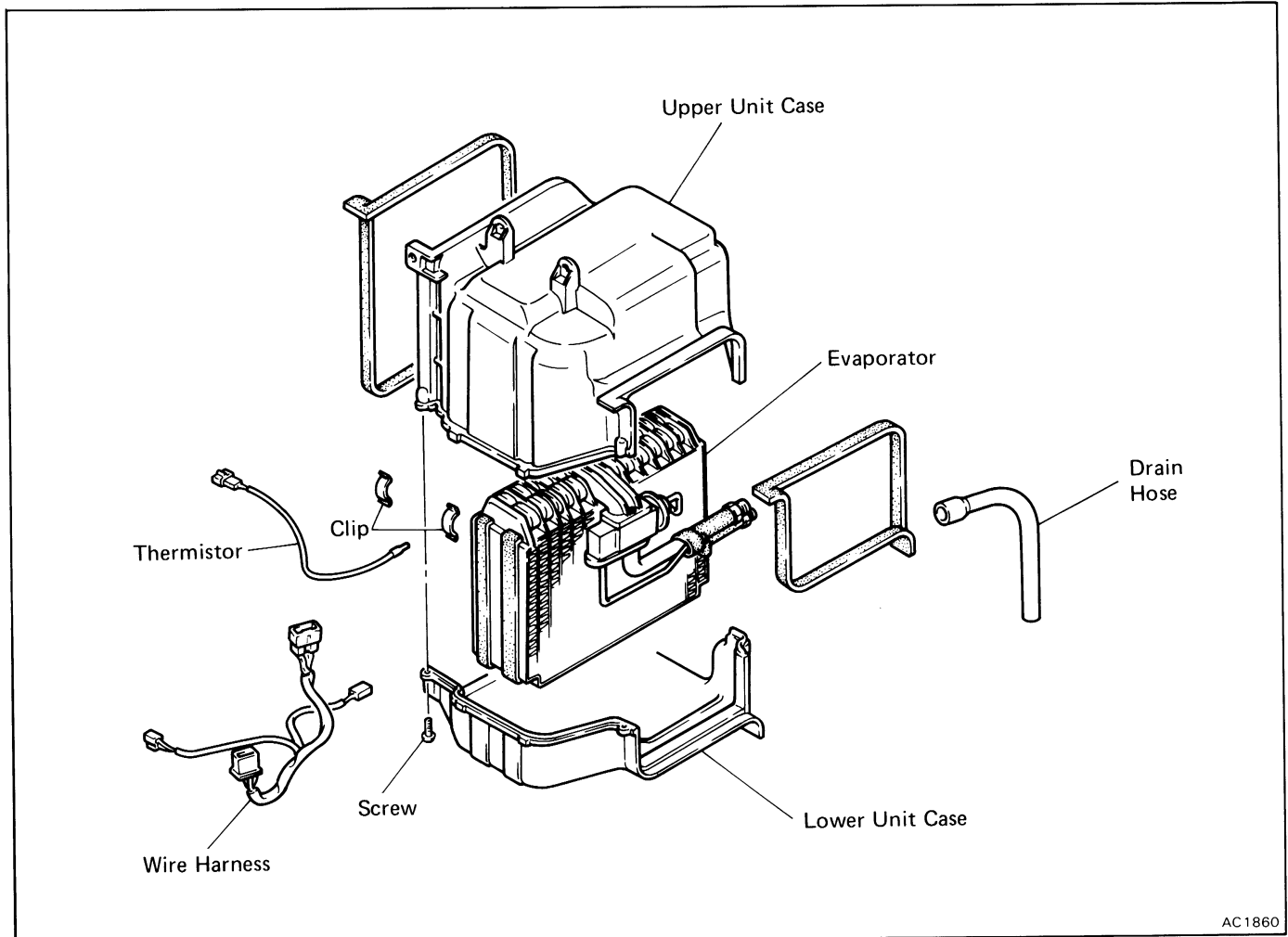

1. REMOVE LOWER AND UPPER CASE

- (a) Remove connector of thermistor from unit case.
- (b) Remove three clips.
- (c) Remove four screws.
- (d) Remove upper unit case.
- (e) Remove thermistor with thermistor holder.
- (f) Remove lower unit case.

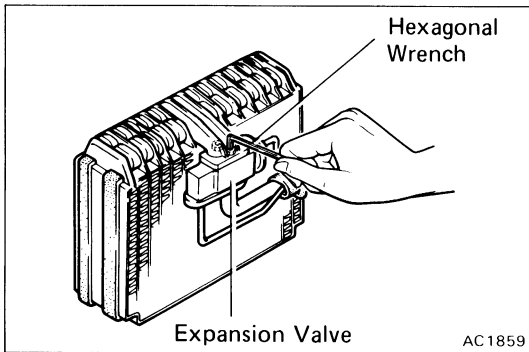

2. REMOVE EXPANSION VALVE

- (a) Remove the packing and heat sensing tube from suction and liquid tubes.
- (b) Remove the expansion valve from the evaporator.

Evaporator

INSPECTION OF EVAPORATOR

1. CHECK EVAPORATOR FINS FOR BLOCKAGE

If the fins are clogged, clean them with compressed air.

NOTICE: Never use water to clean the evaporator.

2. CHECK FITTINGS FOR CRACKS OR SCRATCHES

Repair as necessary.

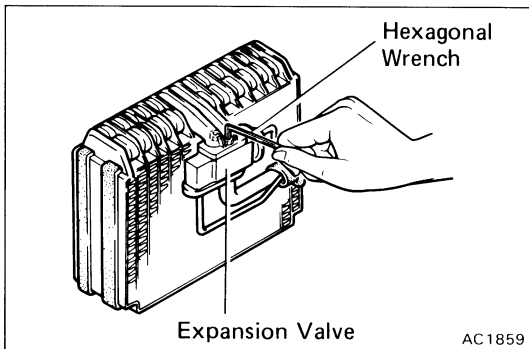

ASSEMBLY OF COOLING UNIT

INSTALL COMPONENTS ON EVAPORATOR

- (a) Connect the expansion valve, suction and liquid tubes to the evaporator. Torque the bolt.

Torque: 55 kg-cm (47.7 in.-lb, 5.4 N·m)

HINT: Be sure that the O-rings are positioned on the tube fitting.

- (b) Install the holder to the suction and liquid tubes with heat sensing tube.
- (c) Install the lower unit case to the evaporator.
- (d) Install the thermistor to the evaporator.
- (e) Install the upper unit case.
- (f) Install the four screws.
- (g) Install three clips.
- (h) Install the connector of thermistor.

INSTALLATION OF COOLING UNIT

1. INSTALL COOLING UNIT

Install the cooling unit with four screws and three nuts.

2. CONNECT CONNECTOR OF THERMISTOR

3. INSTALL EFI AND A.B.S. COMPUTER

4. INSTALL GLOVE BOX COVER AND REINFORCEMENT

5. INSTALL GLOVE BOX AND UNDER COVER

6. INSTALL GROMMETS ON INLET AND OUTLET FITTINGS

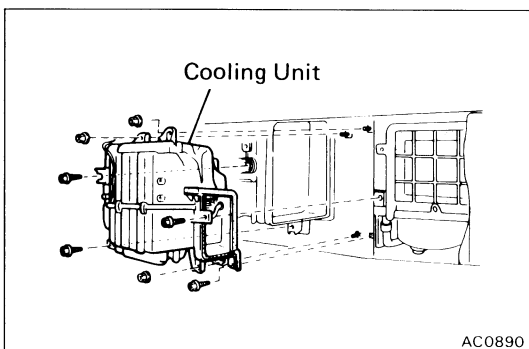

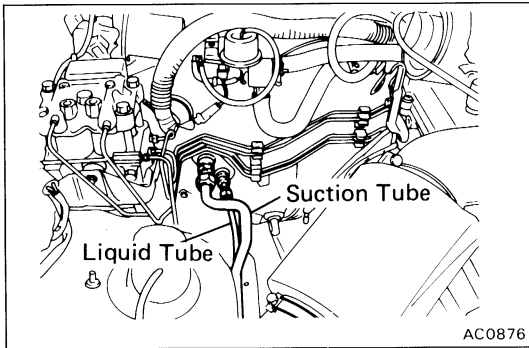

7. **CONNECT LIQUID TUBE TO COOLING UNIT INLET FITTING**
Torque the nut.
Torque: 135 kg-cm (10 ft-lb, 13 N·m)
8. **CONNECT SUCTION TUBE TO COOLING UNIT OUTLET FITTING**
Torque the nut.
Torque: 325 kg-cm (24 ft-lb, 32 N·m)
9. **IF EVAPORATOR WAS REPLACED, ADD COMPRESSOR OIL TO COMPRESSOR**
Add 40 — 50 cc (1.4 — 1.7 fl.oz.)
Compressor oil: **DENSOIL 6,**
SUNISO No.5GS or equivalent
10. **INSTALL CHARCOAL CANISTER WITH BRACKET**
11. **CONNECT NEGATIVE CABLE TO BATTERY**
12. **EVACUATE AIR FROM AIR CONDITIONING SYSTEM**
13. **CHARGE AIR CONDITIONING SYSTEM WITH REFRIGERANT AND CHECK FOR GAS LEAKAGE**
Specified amount: 650 — 750 g (1.4 — 1.7 lb)

REFRIGERANT LINES

(See page AC-8)

ON-VEHICLE INSPECTION

1. **INSPECT HOSES AND TUBES FOR LEAKAGE**
Use a gas leak detector. Replace, if necessary.
2. **CHECK THAT HOSE AND TUBE CLAMPS ARE NOT LOOSE**
Tighten or replace as necessary.

REPLACEMENT OF REFRIGERANT LINES

1. **DISCHARGE REFRIGERATION SYSTEM**
2. **REPLACE FAULTY TUBE OR HOSE**
HINT: Cap the open fitting immediately to keep moisture out of the system.

3. TIGHTENING TORQUE FOR O-RING AND BOLTED TYPE FITTINGS
(See page AC-8)
4. EVACUATE AIR FROM AIR CONDITIONING SYSTEM
5. CHARGE AIR CONDITIONING SYSTEM WITH REFRIGERANT AND CHECK FOR GAS LEAKAGE
Specified amount: 650 — 750 g (1.4 — 1.7 lb)

THERMISTOR

REMOVAL AND INSPECTION OF THERMISTOR

1. DISCONNECT NEGATIVE CABLE FROM BATTERY
2. REMOVE GLOVE BOX AND UNDER COVER
3. CHECK THERMISTOR INSTALLED OPERATION
Using an ohmmeter, measure the resistance at the connector.
Resistance: 1,500 Ω at 25°C (77°F)
If resistance value is not as specified, replace the thermistor.
4. REMOVE THERMISTOR
 - (a) Disconnect the connector.
 - (b) Remove the screw and thermistor from the cooling unit.
5. CHECK THERMISTOR OPERATION
 - (a) Place the thermistor in cold water. While varying the temperature of the water, measure the resistance at the connector and, at the same time, measure the temperature of the water with a thermometer.
 - (b) Compare the two readings on the chart.
 If the intersection is not between the two lines, replace the thermistor.

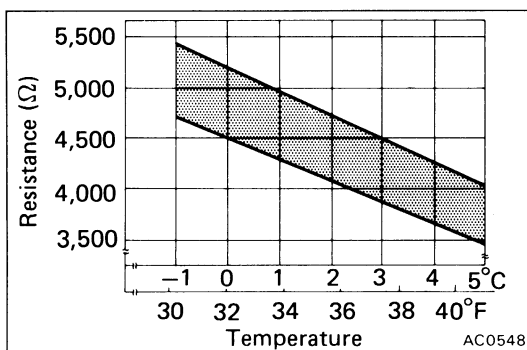
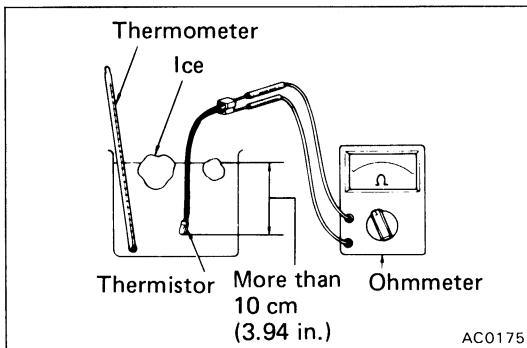

A/C CONTROL PANEL ASSEMBLY

INSPECTION OF A/C CONTROL PANEL ASSEMBLY

1. REMOVE A/C CONTROL PANEL ASSEMBLY

2. MEASURE OUTPUT VOLTAGE

- (a) Connect the positive (+) lead from the battery to terminals 1, 2 and the negative (−) lead to terminal 10.
- (b) Connect the negative (−) lead from the voltage meter to terminal 10 and the positive (+) lead to each terminal (A) with the resistance.
- (c) Check that the output voltage is as shown in the chart below.

HINT: Confirm that each indicator lights are lit with button pushed in.

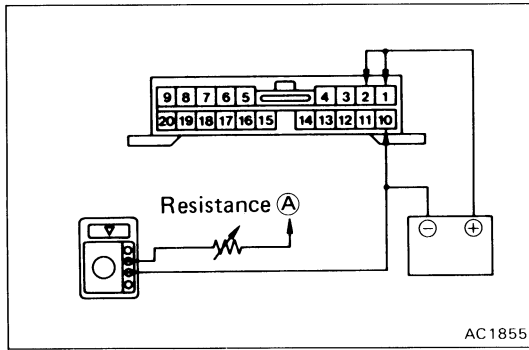
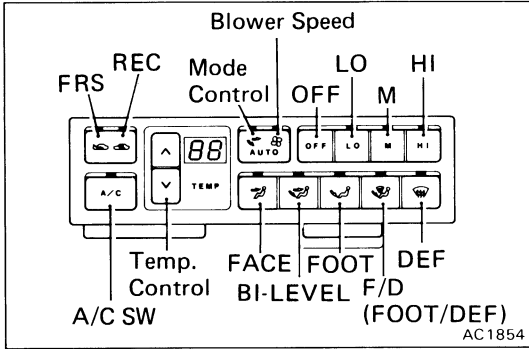

Control Button				Resistance (Ω)	Terminal (A)	Voltage (V)
A/C	FRS/REC	Mode Control	Blower Speed			
OFF	FRS	AUTO	AUTO	620	14	12 or more
					15	1.5 or less
					17	12 or more
					18	1.0 or less
					8	12 or more
					7	1 or less
				19	12 or more	
				16		
				6		
				12		1.5 or less
				3		1 or less
				13		12 or more
ON	REC	DEF	HI	620	4	12 or more
					14	1 or less
					17	1.5 or less
					15	12 or more
					12	
					3	
		12	1 or less			
		13				
		4				
		13		12 or more		
		6		1 or less		
		18		12 or more		
ON	REC	F/D	HI	620	7	1 or less
					16	1 or less
					6	12 or more
					19	1 or less
					16	12 or more
					7	1 or less
ON	REC	BI-LEVEL	HI	620	19	12 or more
					8	1 or less
					7	12 or more
					18	1 or less
					7	12 or more
					18	1 or less
ON	REC	FACE	HI	620	7	12 or more
					18	1 or less
					7	12 or more
					18	1 or less
					7	12 or more
					7	1 or less
ON	REC	AUTO	AUTO	620	7	1 or less

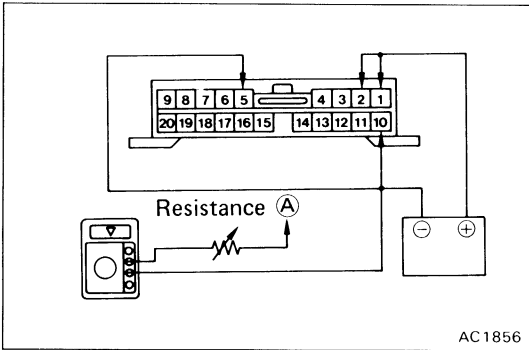

A/C	Control Button			Resistance (Ω)	Terminal (A)	Voltage (V)
	FRS/REC	Mode Control	Blower Speed			
ON	REC	AUTO	AUTO	620	8	1 or less
					7	12 or more
OFF					19	1 or less
					8	12 or more

If the voltage is not as specified, replace the A/C control panel assembly.

AMPLIFIERS

INSPECTION OF AMPLIFIER

INSPECT AMPLIFIER CIRCUIT

Disconnect the amplifier and inspect the connector on the wire harness side as shown in the chart below.

Test conditions:

- (1) Ignition switch: ON
- (2) Temperature control lever: MAX COOL
- (3) Blower switch: HI

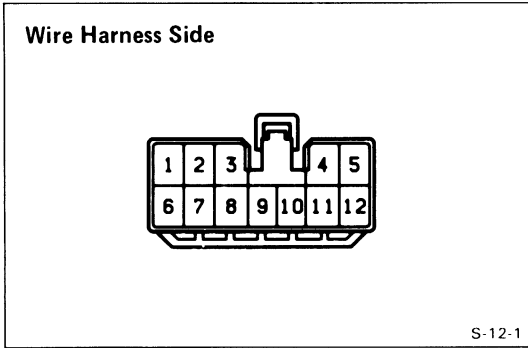

Check for	Tester connection	Condition	Specified value
Continuity	10 – Ground	Constant	Continuity
Voltage	2 – 10	Turn A/C switch on.	Battery voltage
		Turn A/C switch off.	No voltage
Resistance	6 – 9	Constant	Approx. 1.5 kΩ at 25°C (77°F)

INSPECTION OF SYSTEM AMPLIFIER (In A/C Control Panel Assembly)

1. False Signal Input to System Amplifier.

False Signal	A	B
Condition	<p>Interior room temperature is very low.</p> <p style="text-align: right;">AC1370</p>	<p>Interior room temperature is very high.</p> <p style="text-align: right;">AC1371</p>
Your Work	Remove in-car sensor connector	Remove in-car sensor and ground the number 1 pin of in-car sensor female connector

2. System Operation When Input False Signal

Condition: Setting Temperature is at 25°C (77°F)

System Main Parts	False Signal	Motion			
Air Mix Control Servo Motor	A	Air mix control servo motor shaft moves towards max. hot side.			
	B	Air mix control servo motor shaft moves towards max. cool side.			
Air Vent Mode Control Servo Motor		Air Vent Mode Damper			
		VENT	BI-LEVEL	HEAT	DEF
	A	Close	Close	Open	Close
	B	Open	Close	Close	Close
Blower Motor	A	Blower motor rotates at high speed.			
	B				
Water Valve	A	OPEN			
	B	CLOSE			
FRE/REC Control Servo Motor	FRE Switch ON	Fresh air is ventilated.			
	REC Switch ON	Recirculation air is ventilated.			

If necessary, replace the system amplifier.

SENSORS

1. IN-CAR SENSOR

Check the sensor resistance.

HINT: If there is an open circuit in the sensor, the system will operate at maximum heating.

Conversely, if there is a short in the system, it will operate at maximum cooling.

If resistance is not as specified, replace the sensor.

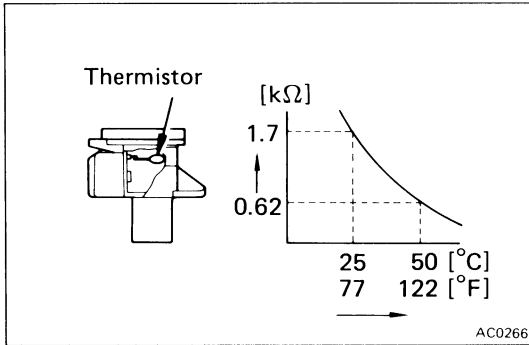
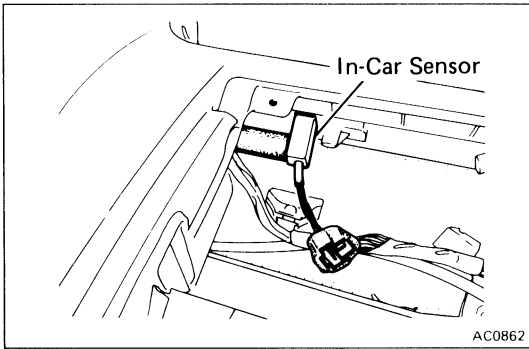

2. AMBIENT SENSOR

Check the sensor resistance.

If resistance is not as specified, replace the sensor.

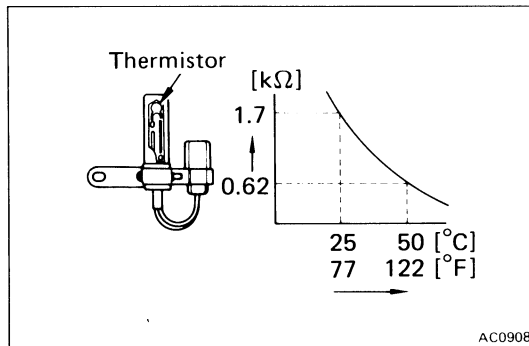
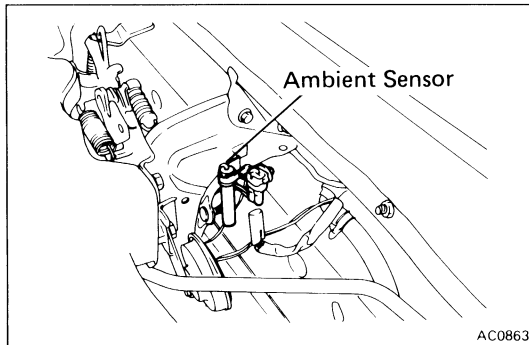

3. SOLAR SENSOR

Using an ohmmeter, check the continuity.

HINT: There is the solar sensor on the safety pad of the assistant side.

If there is no continuity, replace the sensor.

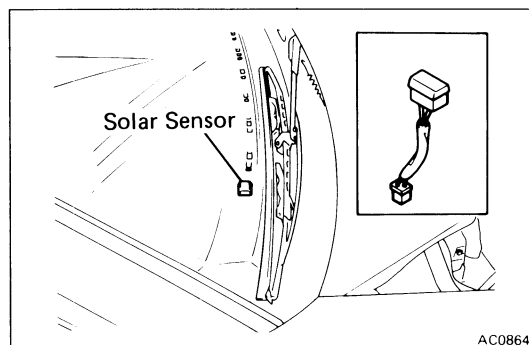

FUNCTIONAL TEST AND ADJUSTMENT

Automatic Temperature Control System

ON-VEHICLE INSPECTION

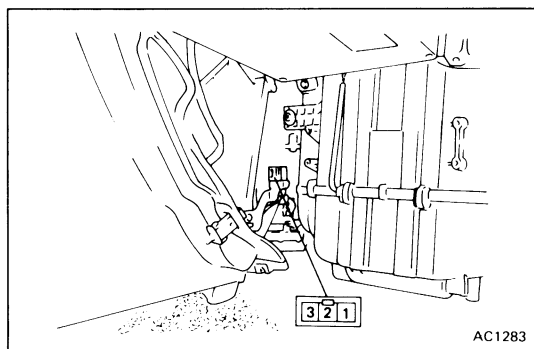

1. DISCONNECT SHORT CIRCUIT CONNECTOR
2. MAKE SHORT TERMINALS 1 AND 3 FOR TEST
3. SET TEMPERATURE CONTROL AT 25°C (77°F)
4. RUN ENGINE AT IDLING
5. TURN ON BLOWER SWITCH TO AUTO POSITION

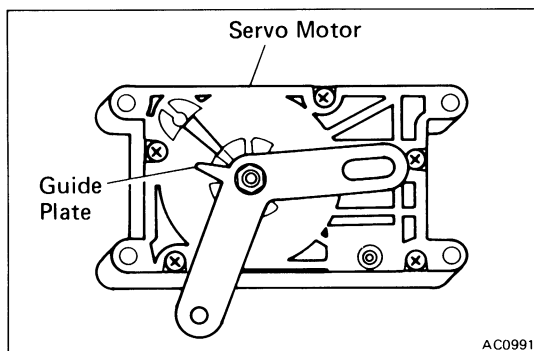

6. CHECK AUTOMATIC TEMPERATURE CONTROL SYSTEM

- (a) Verify that the guide plate on the servo motor is positioned at the mark "O" (between the "R" and "W").
- (b) If the guide plate position is not at the mark "O", adjust as follows.

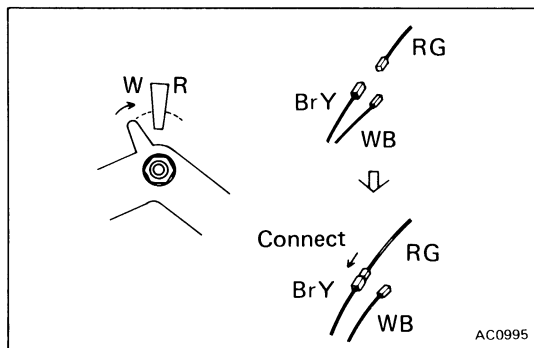

- (c) If the guide plate position is over the "W" area, connect the wire harness RG and Br.Y.

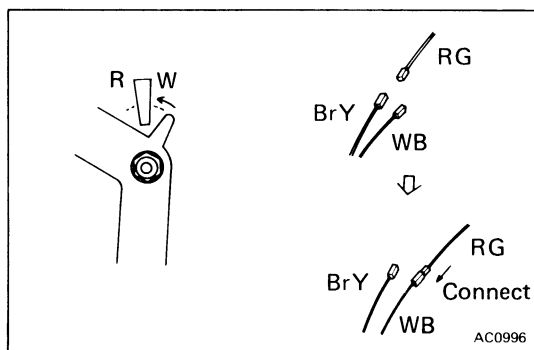

- (d) If the guide plate position is over the "R" area, connect the wire harness RG and WB.

7. CONNECT SHORT CIRCUIT CONNECTOR

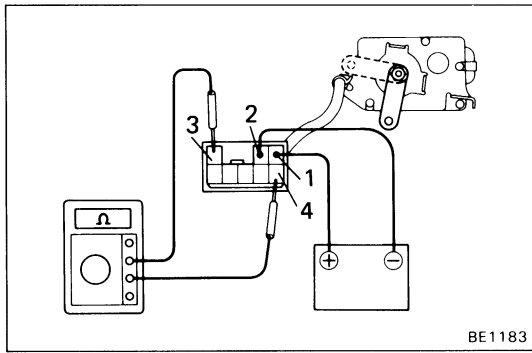

BE1183

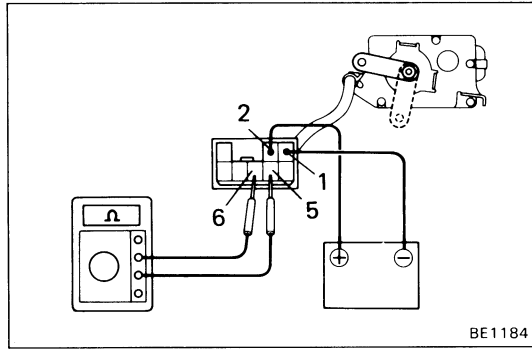

BE1184

RECIRC/FRESH Control Servo Motor

INSPECTION OF RECIRC/FRESH CONTROL SERVO MOTOR

(Operation)

- (a) Connect the positive (+) lead from the battery to terminal 1 and the negative (-) lead to terminal 2.
- (b) Check that the arm rotates smoothly.
- (c) At this time, check for continuity between terminals 3 and 4 as shown in the illustration.
- (d) Connect the positive (+) lead from the battery to terminal 2 and the negative (-) lead to terminal 1.
- (e) Check that the arm rotates smoothly.
- (f) At this time, check for continuity between terminals 5 and 6 as shown in the illustration.

If operation is not as specified, replace the servo motor.

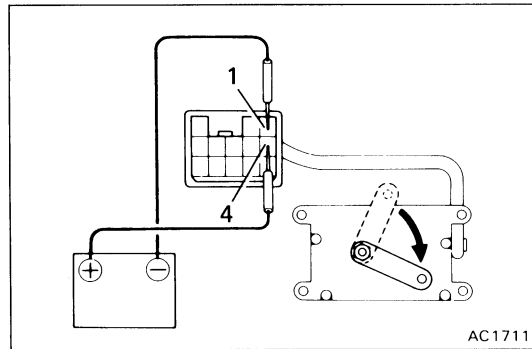

AC1711

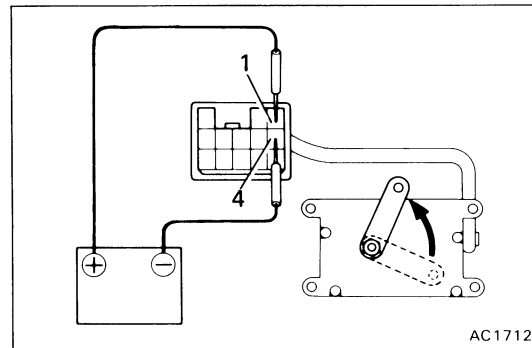

AC1712

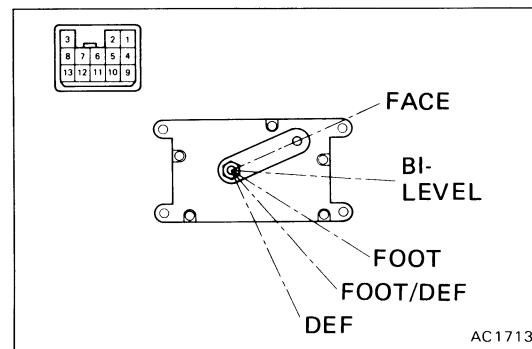

AC1713

Air Vent Mode Control Servo Motor

INSPECTION OF AIR VENT MODE CONTROL SERVO MOTOR

(Operation)

- (a) Connect the positive (+) lead from the battery to terminal 1 and the negative (-) lead to terminal 4.
- (b) Check that the arm rotates smoothly.
- (c) Connect the positive (+) lead from the battery to terminal 4 and the negative (-) lead to terminal 1.
- (d) Check that the arm rotates smoothly.

(Continuity)

Check for continuity between terminal as shown below.

Terminals	2	5	6	7	9	10	11
Arm position							
FACE	○	○	○		○	○	
BI-LEVEL	○	○		○	○	○	○
FOOT	○	○	○	○			○
FOOT-DEF		○	○	○	○	○	○
DEF	○		○	○		○	○

If operation or continuity is not as specified, replace the servo motor.

Air Mix Control Servo Motor

INSPECTION OF AIR MIX CONTROL SERVO MOTOR

(Operation)

- (a) Connect the positive (+) lead from the battery to terminal 10 and the negative (–) lead to terminal 11.
- (b) Check that the lever moves smoothly from WARM to COOL.
- (c) Connect the positive (+) lead from the battery to terminal 11 and the negative (–) lead to terminal 10.
- (d) Check that the lever moves smoothly from COOL to WARM.

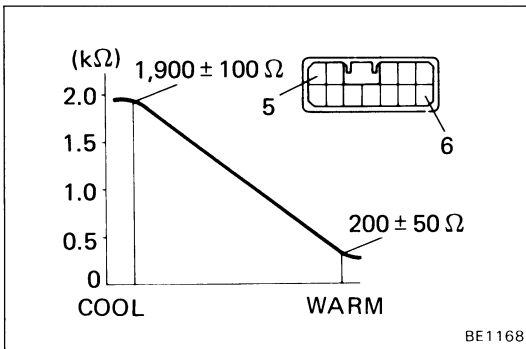
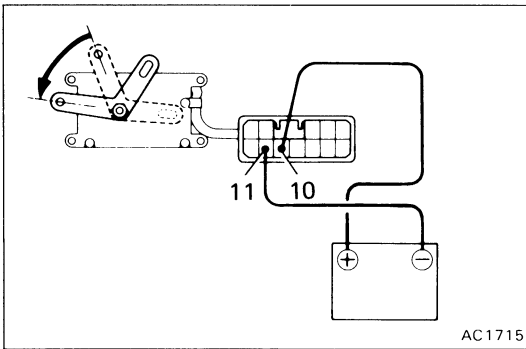
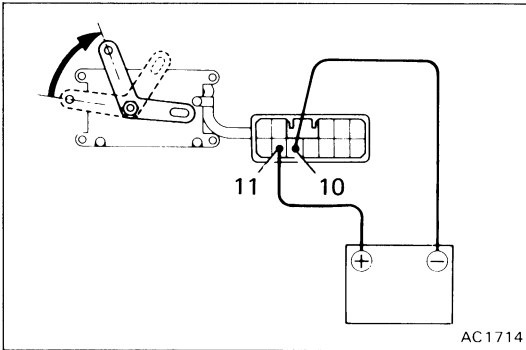

(Resistance)

While operating the servo motor from either points (a) or (b), measure the resistance values of terminals 5 and 6.

Position	Resistance (Ω)
COOL	1,900 ± 100
WARM	200 ± 50

The resistance values from COOL to WARM will successively decrease.

If operation or resistance is not as specified, replace the servo motor.

